

# रेलटेल कॉर्पोरेशन ऑफ इंडिया लिमिटेड

(भारत सरकार का उपक्रम)

पूर्वी क्षेत्र

19वीं मंजिल, ऑरोरा वाटरफ्रंट, जीएन 34/1, ब्लॉक- जीएन, सेक्टर-V,  
साल्ट लेक, बिधाननगर, कोलकाता-700091, पश्चिम बंगाल  
दूरभाष संख्या: 033-44009999, 44041499, फ़ैक्स: 033-44041490

## RailTel Corporation of India Limited

(A Govt. Of India Enterprise)

EASTERN REGION,

19<sup>th</sup> floor, Aurora waterfront, GN 34/1, Block- GN, Sector -V,  
Salt Lake, Bidhannagar, Kolkata-700091, West Bengal  
PH. NO. 033- 4400-9999, 4404-1499, FAX: 033-44041490

जेम बोली संख्या (GeM Bid No.): GEM/2026/B/7389020, Dt. 25.03.2026



RailTel website: <https://www.railtel.in>

GeM portal: <https://gem.gov.in>

“रेलटेल/पूर्वी क्षेत्र के भागलपुर अनुभाग में 2 साल की अवधि के लिए ऑप्टिक फाइबर केबल नेटवर्क के अनुरक्षण और इससे जुड़े अन्य उपकरण जैसे ए.सी., डीजल जनरेटर, स्टेबलाइजर, चेंजओवर यूनिट, शेल्टर और वाई-फाई के रखरखाव के लिए अनुरक्षण दल की तैनाती और जिसे समान शर्तों पर एक साल के लिए बढ़ाया जा सकता है”

के काम के लिए निविदा दस्तावेज़

TENDER DOCUMENT FOR THE WORK OF

“Deployment of maintenance team for maintenance of optic fibre cable network and upkeep of associated gears like AC, DG, Stabilizer, Change over unit, Shelter and Wi-Fi Equipment Bhagalpur section of RCIL/ER for a period of 2 years and extendable by one year on same terms and conditions”

**INDEX**

<b>SL. No.</b>	<b>Chapter No.</b>	<b>SUBJECT</b>	<b>Page No.</b>
NA	NA	NIT	3-5
<b>SECTION-I</b>			
1	1	Annexure-A: Section HQ, Section Details, Length of Section, estimated cost for two years & Earnest Money Deposit details	6-7
2	2	Instructions to Bidders	8-10
3	2A	e -Tendering Instructions to Bidders	11-13
4	3	Check List	14
5	Annexure-1	Declaration of Clean Track Record/ No Black listing	15
6	4	Preamble	16-29
7	5	Introduction	30-49
8	6	Maintenance of Associated assets	50-53
9	7	Jurisdiction of OFC Maintenance Sections & Financial Bid Format	54-56
10	8	Minimum Man & Machine/Equipments required to be engaged under one Maintenance Team	57-59
11	9	Rate of Penalty to be imposed for the non-compliance/deficiency	60-62
12	10	SOR-B Items & Rates	63-70
13	11	Details of Nominated Stores	71
<b>SECTION-II</b>			
14	12	Instructions to e-Tenderers & General Conditions of Contract	72-80
15	13	Special Conditions of Contract	81-92
16	14	Forms & Proforma	93-125
17	15	Bid Data Sheet	126
18	16	Drawings	127-135



## रेलटेल कॉर्पोरेशन ऑफ इंडिया लिमिटेड

पूर्वी क्षेत्र,

**RailTel Corporation of India Limited**

EASTERN REGION,

19<sup>th</sup> floor, Aurora waterfront, GN 34/1, Block- GN, Sector –V,

Salt Lake, Bidhannagar, Kolkata-700091, West Bengal

PH. NO. 033- 4400-9999, 4404-1499, FAX: 033-44041490

**GeM बोली सूचना सं. (GeM Bid Notice No.): GEM/2026/B/7389020, Dt. 25.03.2026**

रेलटेल कॉर्पोरेशन ऑफ इंडिया लिमिटेड (रेलटेल) “रेलटेल/पूर्वी क्षेत्र के भागलपुर अनुभाग में 2 साल की अवधि के लिए ऑप्टिक फाइबर केबल नेटवर्क के अनुरक्षण और इससे जुड़े अन्य उपकरण जैसे ए.सी., डीजल जनरेटर, स्टेबलाइजर, चेंजओवर यूनिट, शेल्टर और वाई-फाई के रखरखाव के लिए अनुरक्षण दल की तैनाती और जिसे समान शर्तों पर एक साल के लिए बढ़ाया जा सकता है” के लिए ई-बोली (एकल चरण, दो पैकेट सिस्टम) आमंत्रित करता है।

RailTel Corporation of India Ltd. (RailTel) invites e-bids (single stage, two packet system) for “Deployment of maintenance team for maintenance of optic fibre cable network and upkeep of associated gears like AC, DG, Stabilizer, Change over unit, Shelter and Wi-Fi Equipments in Bhagalpur Sections of RCIL/ER for a period of 2 years and extendable by one year on same terms and conditions”.

GeM बोली सूचना का विवरण इस प्रकार है:

The details of GeM Bid notice are as under:

a)	i. ई-निविदा के प्रकाशन की तिथि/समय Date/Time of publishing of e-Tender	25.03.2026
	ii. दस्तावेज़ डाउनलोड करने की प्रारंभ तिथि/समय Document downloading start date/Time	25.03.2026 from 17:00 Hrs.
	iii. दस्तावेज़ डाउनलोड करने की अंतिम तिथि/समय Document downloading end date/time	15.04.2026 up to 14:00 Hrs.
	iv. स्पष्टीकरण प्रारंभ दिनांक/समय Clarification start date/time	01.04.2026 from 15:00 Hrs. (Offline)
	v. स्पष्टीकरण समाप्ति तिथि/समय Clarification end date/time	01.04.2026 up to 17:00 Hrs. (Offline)
	vi. बोली जमा करने की आरंभ तिथि/समय Bid submission start date/time	25.03.2026 (Online)
b)	बोली प्रस्तुत करने की अंतिम तिथि/समय Bid submission End date/time	15.04.2026 up to 14:00 Hrs. (Online)
c)	ई-बोली खोलना Opening of e-Bids	15.04.2026 at 14:30 Hrs. (Online)
d)	ई-निविदा का अनुमानित मूल्य Approx. value of e-Tender	As per Annexure-A
e)	बयाना राशि Earnest Money deposit	As per Annexure-A
g)	प्रस्तावों की वैधता Validity of Offers	120 days from opening of bids
h)	टीआरडीएस सुविधा उपलब्ध है? TReDS Feature available?	Yes, on m1xchange portal (Url: <a href="https://www.m1xchange.com">https://www.m1xchange.com</a> )

\*एकल बिंदु पंजीकरण योजना के तहत एनएसआईसी के साथ पंजीकृत सूक्ष्म और लघु-स्तरीय इकाइयां या उद्योग आधार के तहत एमएसई (सूक्ष्म और लघु उद्यम) के रूप में पंजीकृत के लिये, निम्नलिखित छूट उपलब्ध होगी:

(ए) उन्हें निविदा दस्तावेज की लागत से छूट दी जाएगी (यदि लागू हो)।

(बी) उन्हें बयाना राशि जमा करने से भी छूट दी जाएगी

(सी) सार्वजनिक खरीद नीति आदेश, 2012, सूक्ष्म और लघु उद्यम (एमएसई) के अनुसार एमएसई को खरीद प्राथमिकता इस निविदा पर लागू होती है।

(कृपया निविदाकारों को निर्देश और अनुबंध की सामान्य शर्त (जीसीसी) के खंड संख्या 5.8 देखें)।

\*Small scale units registered with NSIC under single point registration scheme or registered as MSE (micro and small enterprises) under Udyog Aadhar, the following exemption shall be available:

(a) They shall be exempted from cost of Tender document (If applicable).

(b) They shall also be exempted from submitting depositing Earnest money.

(c) Purchase preference to MSE is applicable to this tender as per Public Procurement Policy Order, 2012, Micro and Small Enterprises (MSEs).

(Kindly refer to clause no. 5.8 of instructions to tenderers and general condition of contract (GCC)

यदि फर्म एनएसआईसी या एमएसएमई के साथ एमएसई के रूप में पंजीकृत है, तो बयाना राशि और निविदा दस्तावेज की लागत से छूट के लिए एनआईटी के अनुसार समान कार्यक्षेत्र के साथ वैध पंजीकरण प्रमाण पत्र की प्रति प्रस्तुत की जानी है। ये छूट लागू होगी बशर्ते इकाइयाँ एनएसआईसी या एमएसई के तहत निविदा मद के लिए पंजीकृत हों और पंजीकरण चालू और वैध हो। इन छूटों का दावा करने वाली फर्म को अपने प्रस्ताव के साथ एनआईटी के अनुसार समान कार्यक्षेत्र के साथ वैध पंजीकरण प्रमाण पत्र की प्रति प्रस्तुत करना आवश्यक है अन्यथा उनके प्रस्ताव पर विचार नहीं किया जाएगा।

In case firm is registered with NSIC or under MSE, copy of valid registration certificate with same scope of work as per NIT for exemption of EMD and cost of Tender document, is to be submitted. These exemptions shall be applicable provided units are registered with NSIC or under MSE for tendered item and registration is current and valid. Firm claiming these exemptions are required to submit copy of valid registration certificate with same scope of work as per NIT, along with their offer otherwise their offer would not be considered.

**नोट:** निविदा सूचना और निविदा दस्तावेज रेलटेल की वेबसाइट पर उपलब्ध हैं और इसे <https://www.railtel.in> या GeM पोर्टल <https://gem.gov.in> से डाउनलोड किया जा सकता है। ऑनलाइन बोली जमा करने के लिए निविदाकार को GeM पोर्टल से निविदा दस्तावेज की एक आधिकारिक ऑनलाइन प्रति अनिवार्य रूप से डाउनलोड करनी होगी। इस GeM बोली के लिए भविष्य की सभी जानकारी अर्थात् शुद्धिपत्र / परिशिष्ट / संशोधन आदि केवल GeM पोर्टल पर पोस्ट किए जाएंगे। निविदा दस्तावेज की मुद्रित प्रति रेलटेल कार्यालय से नहीं बेची जाएगी। किसी अन्य माध्यम से प्रस्तुत/भेजी गई बोली स्वीकार नहीं की जाएगी।

**Note:** Tender Notice and Tender Document are available on RailTel's website and can be downloaded from <https://www.railtel.in> or from the GeM Portal <https://gem.gov.in>. For online bid submission the tenderer will have to necessarily download an official online copy of the Tender document from GeM portal. All future Information viz. corrigendum / addendum/ amendments etc. for this GeM Bid shall be posted on RailTel website and GeM portal only. Printed copy of Tender document will not be sold from RailTel office. Bid submitted/sent by any other mode will not be accepted.

बोलीदाता बोली तैयार करने, प्रस्तुत करने/भाग लेने से संबंधित सभी लागतों को वहन करेगा। बोली प्रक्रिया के संचालन या परिणाम की परवाह किए बिना खरीदार इन लागतों के लिए किसी भी तरह से जिम्मेदार या उत्तरदायी नहीं होगा।

The bidder shall bear all costs associated with the preparation, submission/participation in the bid. Purchaser in no way will be responsible or liable for these costs regardless of the conduct or outcome of the bidding process.

"ई-बोलीदाता" का अर्थ एक कंपनी या फर्म या एजेंसी है जो इस GeM बोली में भाग लेती है और ई-बोली जमा करती है (इसके बाद "ई-बोलीदाता" और "ई-बोली" को क्रमशः "बोलीदाता और बोली" के रूप में संदर्भित किया जाएगा।

The "e-bidder" means a Company or Firm or Agency who participates in this GeM Bid and submit e-bid (hereafter "e-bidder" and "e-bid" shall be referred as "bidder & bid" respectively.

GeM बोली के संबंध में बयाना राशि जमा (ईएमडी) का भुगतान केवल नेट बैंकिंग या डिमांड ड्राफ्ट के माध्यम से स्वीकार किया जाएगा। GeM बोली के लिए सावधि जमा रसीद (एफडीआर) को बयाना राशि के रूप में स्वीकार नहीं किया जाएगा।

Payment of Earnest money deposit (EMD) in respect of GeM Bid, will be accepted through net banking or through Demand Draft. Fixed deposit receipt (FDR) will not be accepted as EMD for GeM Bids.

ऑनलाइन स्थानांतरण के लिए रेलटेल का बैंक खाता विवरण नीचे दिया गया है:/

The bank Account Details of RailTel for online transfer is furnished below:

Name of the Bank and Address	Union Bank of India, Chowringhee Road Branch, 1/1 Camac Street, Ground Floor, Kolkata – 70001
Name of the account holder	RAILTEL CORPORATION OF INDIA LIMITED
Account No.	401601010519491
IFSC Code	UBIN0540161

RailTel Corporation of India Ltd.

(A Member of the Category 1 E-Procurement)

**महाप्रबंधक/संचालन**  
**General Manager/Operation**

## SECTION-I

### Chapter- 1

#### Annexure-A

GeM Bid Nos.: GEM/2026/B/7389020, Dt. 25.03.2026

### Section HQ, Section Details, Length of Section, estimated cost for 02 (two) years & EMD amount details

RailTel Corporation of India Ltd., Eastern Region invites open e-tenders from the established and reliable contractors with proven experience for the work of “Deployment of maintenance team for maintenance of optic fibre cable network and upkeep of associated gears like AC, DG, Stabilizer, Change over unit, Shelter and Wi-Fi Equipments in **Bhagalpur** sections of RCIL/ER for a period of 2 years and extendable by one year on same terms and conditions”.

Sl. No.	GeM Bid No.	Sectional HQ	Section Details	Sub section length	Total Length of Section (RKM)	Estimated Tender Value for 02 (two) years [OFC + Associated gears] (Rs.) (Including GST)	Earnest Money Deposit (@ 2% of Gross value i.e. including GST as applicable (Rs.) Rounded off to next Rs.1000/-
1	GEM/2026/B/7389020, Dt. 25.03.2026	Bhagalpur	Kiul- Jamalpur	45.00	196.00	50,87,140/-	1,02,000/-
			Jamalpur- Bhagalpur	53.00			
			Bhagalpur- Pirpaiti	50.00			
			Bhagalpur - Barahat	41.00			
			Jamalpur-Munger	7.00			

Details of sections which are being tendered are as below.

**Note:**

1. City Access network will also be maintained by the maintenance team which will be up to around 15 % of total section length.
2. SOR- A: The detailed Scope of work is described on item no. 2.1 to 2.13.
3. Pre bid meeting will be held on 01.04.2026 at 15:00 hours.

Venue of the meeting will be at, Conference Room RailTel Corporation of India Ltd. Eastern Region, 19<sup>th</sup> Floor, Aurora waterfront, GN 34/1, Block- GN, Sector –V, Salt Lake, Bidhannagar, Kolkata-700091, West Bengal.

4. Detail of sections which are being tendered is as enclosed as above.
5. Separate supporting documents for eligibility criteria and Tender Document to be submitted for Each section by the bidder in the GeM Portal if the bidder desires to bid for more than one section.

**General Manager/Operations  
For and on behalf of RailTel Corporation of India Limited**



रेलटेल  
RAILTEL

RailTel Corporation of India Ltd.

(A Minorana Category - 1 Enterprise)

## Chapter- 2

### INSTRUCTIONS TO THE BIDDERS

#### 2.0 General

These are the Special Instructions to the Bidders for Tendering.

The RailTel Tenders are published on <https://www.railtel.in> and on e-Procurement Portal <https://gem.gov.in>.

For E-Tendering bids /information by bidders is to be submitted "Online" on e- Procurement Portal <https://gem.gov.in>. Any document / information pertaining to this tender will have to be submitted by the bidder online. The digital signature of the tenderer on the e-tender form will be considered as confirmation that the tenderer has read, understood and accepted all the documents, unless special deviation is quoted by the tenderer in the technical & commercial deviation templates.

Please note all columns should be filled and blank columns,if any, should be marked as nil.

Please read carefully all the clauses of the tender before uploading the tender form. please sign on each page.

The tenderer may download tender form from the web site '<https://www.railtel.in>' or from the e-Procurement Portal <https://gem.gov.in>'.

NOTE: For online bid submission the tenderer will have to necessarily download an official online copy of the tender documents from e-Procurement Portal <https://gem.gov.in> and this should be done well before the deadline for bid- submission.

#### 2.1 Submission of the bid:

The bidder is required to submit the technical bid and Price bid in GeM portal before due date & time of submission of bids specified in this tender document.

2.2 Following documents shall be submitted in Technical and Price bid as given below:

(a) **"TECHNICAL BID"**; -The bid shall consist of the following: -

- 1) Completely filled Offer Letter (Form-III).
- 2) Signed/Digitally Signed Copy of Tender Document/ Corrigendum
- 3) EMD/ Proof of submission of EMD
- 4) E-receipt of Tender fee. **Not Applicable**
- 5) Power of attorney to be submitted
- 6) In case bidder happens to be an eligible MSE, the documentary evidence for the same shall be submitted
- 7) Documentary proof of qualifying criteria
- 8) Affidavit (Annexure-B-1) & Bid Security

- 9) Declaration Annexure-B-2: For MSEs).
- 10) Declaration of Clean Track Record/ No Black listing (Annexure-1)
- 11) Any other document asked in the tender but not listed above.
- 12) Any Other information desired to be submitted by the tenderer

**b) “Price Bid” Shall contain**

The price bid for “Schedule of requirements” as per Note of Chapter- 2 for each item quoted exactly according to the proforma, as also submitted.

**Note: Non-submission of the above-mentioned documents may lead to rejection of the bid.**

**2.3 Fax Quotations & Late Tenders:**

Fax Tender documents and Late/Delayed tenders would not be considered.

**2.4 Attendance of Representatives for Tender Opening:**

Representatives of tenderers desirous to attend the tender opening can do so on production of a proper letter of authority from the respective firm, failing which they may not be allowed to attend the tender opening.

**2.5 Addenda / Corrigenda:**

Addenda / Corrigenda to the tender documents may be issued by RailTel prior to the date of opening of the tenders, to clarify or reflect modifications in the contract terms and conditions. Such addendum/corrigendum shall be available on RailTel Website & GeM portal. Tenderers who are unable or unwilling to bring their tenders to conform to the requirements of the RailTel are liable to be rejected.

**2.6 Bid submission and Opening date**

2.6.1 The bid should be submitted along with Technical & Price bid document (all documents) in GeM portal as per date & time given in the Bid document.

2.6.2 The tenderer’s bids will be opened at the time & date of opening of the tender given in the Tender Notice in presence of such Tenderers present who choose to be present.

Bids received after due date and time shall be summarily rejected and shall not be opened.

2.6.3 **Submission of offline documents:**

The bidder is required to submit the following documents offline to RailTel Corporation of India Limited, Eastern Region, 19<sup>th</sup> floor, Aurora waterfront, GN 34/1, Block- GN, Sector –V, Salt Lake, Bidhannagar, Kolkata-700091, West Bengal before due date and time of submission of bids specified in this tender document, in a sealed envelope. The envelope shall bear the tender name, GeM Bid No..... and the words “DO NOT OPEN BEFORE (DUE DATE & TIME):

1. Original Power of Attorney in favour of the signatory duly authorizing the signatory **(Mandatory)**.
2. Original Notarized affidavit as per format provided in Annexure-B-1 **(Mandatory)**.
3. Bid Security Declaration in Annexure-B-2 (applicable for MSEs) **(Mandatory)**

रेलटेल  
RAILTEL

RailTel Corporation of India Ltd.

(A Minor and Category 1 Enterprise)

**Section - I**

**CHAPTER- 2A**

**E-tendering Instructions to Bidders**

**2A.0 GENERAL:**

These Special Instructions (for e-Tendering) supplement 'Instruction to Bidders', as given in Chapter- 3 of the Tender Document. Submission of Bids only through online process is mandatory for this Tender.

E-Tendering is a new methodology for conducting Public Procurement in a transparent and secured manner. Now, the Government of India has made e-tendering mandatory. Suppliers/ Vendors will be the biggest beneficiaries of this new system of procurement. For conducting electronic tendering, RailTel has decided to use the portal <https://gem.gov.in>. Bidder Enrolment can be done using "Online Bidder Enrolment".

The instructions given below are meant to assist the bidders in registering on the e- tender Portal and submitting their bid online on the e-tendering portal as per uploaded bid. More information for submitting online bids on the GeM Portal may be obtained at: <https://gem.gov.in>.

**2A.1 GUIDELINES FOR REGISTRATION:**

1. Bidders are required to register on the e-Procurement Portal: <https://gem.gov.in> available on the home page of e-tender Portal.
2. As part of the enrolment process, the bidders will be required to choose a unique username and assign a password for their account.
3. Bidders are advised to register their valid email address and mobile numbers as part of the registration process. These would be used for any communication with the bidders.
4. The scanned copies of all original documents should be uploaded in pdf format on e-tender portal.

**2 A2 SEARCHING FOR TENDER DOCUMENTS:**

There are various search options built in GeM Portal, to facilitate bidders to search active tenders by several parameters.

Once the bidders have selected the tenders they are interested in, bidders can pay/submit the EMD in the following forms:

EMD can be submitted in the form of Demand Draft/Pay Order/Banker's Cheque drawn in favour of "RailTel Corporation of India Ltd." payable at Kolkata on or before 14:00 hrs. on bid opening date. The Bid received without EMD will be summarily rejected.

In addition to above, Tenderer has an option for online submission of EMD also. The EMD should be remitted in following account of RailTel Corporation of India Limited before the stipulated time and date of bid submission:

The bank Account Details of RailTel for online transfer is furnished below:

Name of the Bank and Address	Union Bank of India, Chowringhee Road Branch, 1/1 Camac Street, Ground Floor, Kolkata – 70001
Name of the account holder	RAILTEL CORPORATION OF INDIA LIMITE
Account No.	401601010519491
IFSC Code	UBIN0540161

### 2A.3 **PREPARATION OF BIDS:**

1. Bidder should take into account any corrigendum published on the tender document before submitting their bid.
2. Please go through the tender notice and the tender document carefully to understand the documents required to be submitted as part of the bid.
3. Bidder, in advance, should get ready the bid documents to be submitted as indicated in the tender document / schedule and generally, they can be in PDF formats. Bid Original documents may be scanned with 100 dpi with Colour option, which helps in reducing size of the scanned document.

### 2A.4 **SUBMISSION OF BIDS:**

2A.4.1 Bidder should log into the GeM Portal well in advance for the submission of the bid so that it gets uploaded well in time i.e. on or before the bid submission time. Bidder will be responsible for any delay due to other issues.

2A.4.2 The bidder has to digitally sign and upload the required bid documents one by one as indicated in the tender document as a token of acceptance of the terms and conditions laid down by RailTel.

- 2A.4.4 Bidders are requested to note that they should necessarily submit their financial bids in the format provided and no other format is acceptable. If the price bid has been given as a standard BOQ format with the tender document.
- 2A.4.5 The server time (which is displayed on the bidders' dashboard) will be considered as the standard time for referencing the deadlines for submission of the bids by the bidders, opening of bids etc. The bidders should follow this time during bid submission.
- 2A.4.6 The uploaded tender documents become readable only after the tender opening by the authorized bid openers.

**2A.5 For any clarification in using GeM Portal:**

2A.5.1 Any queries relating to the tender document and the terms and conditions contained therein should be addressed to the Tender Inviting Authority for a tender or the relevant contact person indicated in the tender.

2A.5.2 Any queries relating to the process of online bid submission or queries relating to GeM Portal in general may be directed to the Helpdesk Support.

GeM helpdesk address: helpdesk-gem[at]gov[dot]in  
Toll Free Numbers (Inbound): Call  
1800-419-3436 / 1800-102-3436  
( 9:00 am - 10:00 pm Mon to Sat)

**1. RailTel Contact-I (for general Information)**

RailTel's Contact Person: Sh. Pooran Singh, AGM/Tender

Mobile No. 9007044140, E-mail ID: pooransingh@railtelindia.com

**2. RailTel Contact-II (for general Information)**

RailTel's Contact Person: Mr. Rashid Hassnain, DGM/O&M

Mobile No. 9002044173, E-mail ID: rashidhassnain@railtelindia.com

**Chapter- 3****Check List for Tenderer before submission of e-Tender and eligibility of tenderer:**

S.N.	Description	Submitted/ Not submitted
1.	EMD as per NIT/ Preamble or Supporting Documents for exemption from submission of EMD: <b>Mandatory</b>	
2.	<b>Online &amp; Offline</b> submission of Bid Security Declaration (applicable for MSEs) as per NIT/ Preamble <b>Mandatory</b>	
3.	Signed/Digitally Signed Copy of Complete Tender Document: <b>Mandatory</b>	
4.	Submission of required documents against technical & financial eligibility criteria: <b>Mandatory</b>	
5	<b>Online &amp; Offline</b> Submission of Notarized Affidavit in Original (Annexure-B-1): <b>Mandatory</b>	
6	<b>Online &amp; Offline</b> Submission of Power of attorney/Authorization: <b>Mandatory</b>	
7.	Submission of Clause wise compliance and deviation statement to the tender condition and statement of deviation, if any.	
8.	<b>Price Bid submission:</b> The bidder shall quote rate against total advertised Tender value (Total Amount)	
9.	Copy of PAN card, GSTIN Registration certificate.	
10.	Audited balance sheet for last Three financial years (FY 2021-22, 2022-23, 2023-24) & current year: <b>Mandatory</b>	
11.	Proposed Deployment plan.	
12.	Constitution of Firm	
13.	Similar Works executed or under execution	
14.	User Certificates	
15.	Any Other Information desired to be submitted by the Tenderer	
16.	List of Personnel/Manpower	
17.	List of Plant & Machinery	
18.	Solvency certificate from a Nationalized/ Scheduled bank for a minimum value of 40% of the annual value of the tendered sections. If quoted cost is < 1 Cr, this condition will not apply: <b>Mandatory</b>	
19.	Declaration of Clean Track Record/ No Black listing: <b>Mandatory</b>	

**Note:** 1. If needed, separate Work Order will be issued by RailTel for execution of some of the items against 'SOR-B' as per rates indicated by RailTel. Confirm your acceptance of the same by digitally signing on SOR-A, SOR-'B', the tenderer shall quote the rates in GeM Portal for SOR-A only as per Financial Bid Format given in chapter 7. For execution of items against SOR-B, no minimum work can be indicated, however, the maximum amount against SOR-B shall normally be kept at 40% of SOR-A value per annum for OFC diversion works, marketing requirement and improvement works etc.

2. Failure to submission of mandatory Documents shall be liable to be rejected.
3. Read carefully and understand each clause of the Tender Document.

**Signature of Tenderer with Seal**

ANNEXURE-1

**Declaration of Clean Track Record/No Blacklisting**

(To be submitted by Bidder on original letter head)

To,

Date

Principal Executive Director,  
RailTel Corporation of India Ltd.,  
Eastern Region, 19thFloor,  
Aurora Waterfront Building,  
Plot No. 34/1, Block GN, Sector-V,  
Salt Lake, Kolkata-700 091

**Sub:** Deployment of maintenance team for maintenance of optic fibre cable network and upkeep of associated gears like AC, DG, Stabilizer, Change over unit, Shelter and Wi-Fi Equipments in Bhagalpur section of RCIL/ER for a period of 2 years and extendable by one year on same terms and conditions.

**Ref:** GeM Bid No. GEM/2026/B/7389020, Dt. 25.03.2026.

Sir,

I/We hereby declare that my company has not been debarred / black listed as on Bid submission date by any State Government, Central Government, Central & State Govt. Undertakings/ Organizations and by any other Quasi Government bodies/ Organizations, and any other major Enterprise / Organizations in India for non-satisfactory past performance, corrupt, fraudulent or any other unethical business practices.

RailTel Corporation of India Ltd. Yours faithfully,

(A Minor/MSME Category - 1 Enterprise)

(Signature, name and designation of the authorized signatory)

(Name and seal of the firm)

## Chapter- 4

### PREAMBLE

S. No.	1. Name of the work
1	Deployment of maintenance teams for maintenance of OFC cable network and associated equipment etc. for a period of 2 years and extendable by one year on same terms and conditions. (SOR-A)
2	OFC improvement works and other minor/Diversion works (SOR-B)
3	Up-keep of infrastructure like AC machine, DG sets, shelter, power plant and associated control equipment etc. (SOR-C)
4	Up keep of Wi-Fi related assets like Fiber, Switches, UPS, Battery, AP, LAN & Power Cables etc. An exclusive diploma engineer shall be Deployed for the purposes. (SOR-A)

The contract shall be extendable by 01 (one) year on same terms & conditions.

#### 2. SUBMISSION OF eTender BID:

##### 2.1 The tender bid shall be submitted as below:

The bids shall be submitted online on e-Tendering portal <https://gem.gov.in>, which should describe the GeM Bid No. **GEM/2026/B/7389020**, Dt. **25.03.2026**, its description, section name and date of opening. The complete Offline Documents shall be addressed to:

**General Manager/Operations,**  
Eastern Region

RailTel Corporation of India Limited,  
19<sup>th</sup> floor, Aurora waterfront, GN 34/1,  
Block- GN, Sector –V, Salt Lake, Bidhannagar,  
Kolkata-700091, West Bengal

**Last Date of submission of tenders:** The bids for the GEM Bid No. **GEM/2026/B/7389020**, Dt. **25.03.2026**, will be received only in online system at e-Tendering Portal (<https://gem.gov.in>), up to **14:00** hrs. IST of Date **15.04.2026** and will be opened at **14:30** hrs. on same day. If the above said day happens to be a holiday, the tender shall be opened on the next working day at the given time.

##### 2.2 Restriction regarding Bidding:

No adjacent sections will be awarded to the same contractor to ensure redundancy of resources to maintain SLA. Adjacent sections of tendered sections are following:

Sl. No	Section HQ	Territory	Adjacent section HQ
1	Bhagalpur	NJP	Luckeesarai, Dumka, Mokama and Tinpahar

**If any contractor executing OFC Maintenance work/ participating in the adjacent sections, their bid will not be considered as eligible offer.**

### 3. ELIGIBILITY CRITERIA FOR GENERAL BIDDERS:

The bidder/tenderer should have the following Technical & Financial capabilities for each section that the tenderer is quoting:

#### 3.1 Technical Capability:

**Tenderers should have:**

- (a) Performed OFC route (underground cable) maintenance for a continuous stretch of more than 150 Kms (One hundred fifty kilometres) for a minimum period of 1 (One) year in the past three financial years & current year before the date of opening of tender.

**Or**

- (b) Should have executed trenching, laying, splicing and termination of OFC for a continuous stretch of 50 Kms (Fifty Kilometre) in a single contract or a combined length of minimum 200 Km (Two Hundred Kilometres) in the past three financial years & current year before the date of opening of tender.

**Or**

- (c) Performed OFC route (overhead cable) maintenance of more than 200 Kms (Two hundred kilometres) for a minimum period of 1 (One) year in the past three financial years & current year before the date of opening of tender.

#### **Note:**

- 1) Tenderers must have completed the above-mentioned works either for Govt. / public Sector or for reputed private sector telecom service providers/Infrastructure Provider with satisfactory performance report from the client.
- 2) Tenderer must have completed the above-mentioned works in the last three financial years & current year reckoned from the date of opening of the tender.
- 3) No consortium/ Joint Bid shall be allowed.
- 4) Certified copies of the necessary experience certificates to this effect shall be enclosed along with the tender document while quoting for establishing credentials. Satisfactory experience certificates from the user department attesting to this fact shall be enclosed.
- 5) The Tenderer should submit undertaking to stipulates that bidder has a positive net worth.

#### 3.2 Financial Capability:

- a) The tenderer must have received total contract value of 150 % of the advertised value of tendered sections for which they are participating in the past three financial years & current year before the date of opening of tender.

- b) The tenderer should produce:
- (i) Solvency certificate from a Nationalized/ Scheduled Bank for a minimum value of 40% of the annual value of the tendered sections. If the quoted cost is < 1 Cr, this condition will not apply.
  - (ii) Audited balance sheet and income statement of all the preceding three Financial years and PAN Number.
  - (iii) The contractor should submit copy of GST registration certificate for the states wherever applicable.
  - (iv) For current year where audited accounts are not available, statement of gross revenue/contract receipts may also be submitted duly certified by chartered accountant.

### 3.B ELIGIBILITY CRITERIA FOR STARTUP FIRMS ONLY:

**The Startup Bidder/tenderer** (having valid "Certificate of Recognition" recognized as a startup by the Department of industrial Policy and Promotion) should have the following Technical & financial capabilities for section that the tenderer is quoting:

#### 3.1 Technical Capability:

Tenderers should have:

(a) Performed OFC route (underground cable) maintenance for a continuous stretch of more than 60 Kms (Sixty kilometres) for a minimum period of 1 (One) year in the past three financial years & current year before the date of opening of tender.

Or

(b) Should have executed trenching, laying, splicing and termination of OFC for a continuous stretch of 20 Kms (Twenty Kilometres) in a single contract or a combined length of minimum 80 Km (Eighty Kilometres) in the past three financial years & current year before the date of opening of tender.

Or

(c) Performed OFC route (overhead cable) maintenance of more than 80 Kms (Eighty kilometres) for a minimum period of 1 (One) year in the past three financial years & current year before the date of opening of tender.

#### Note:

- 1) Tenderers must have completed the above-mentioned works either for Govt. / public Sector or for reputed private sector telecom service providers/Infrastructure Provider with satisfactory performance report from the client.
- 2) Tenderer must have completed the above-mentioned works in the last three financial years & current year reckoned from the date of opening of the tender.
- 3) No consortium/ Joint Bid shall be allowed.
- 4) Certified copies of the necessary "Work completion certificate" and experience certificates to this effect shall be enclosed along with the tender document while quoting for establishing credentials.

### 3.2 Financial Capability:

- a) The tenderer must have received annual turnover of minimum 50% of the advertised value of tendered section for which they are participating in the past three financial years & current year before the date of opening of tender.
- b) The tenderer should produce:
  - (i) Solvency certificate from a Nationalized/ Scheduled Bank for a minimum value of 40% of the annual value of the tendered sections. If the quoted cost is < 1 Cr, this condition will not apply.
  - (ii) Audited balance sheet and income statement of all the preceding three financial years and PAN Number.
  - (iii) The contractor should submit copy of GST registration certificate for the states wherever applicable.
  - (iv) For current year where audited accounts are not available, statement of gross revenue/contract receipts may also be submitted duly certified by chartered accountant.

**Note:-** Firms claiming these relaxations are required to submit along with their offer, a copy of their current and valid Startup registration certificate otherwise their offer would not be considered for relaxation.

- 3.3** In case the tenderer wants to quote for multiple sections, the financial and technical criterion given above will have to be separately met for each section being quoted i.e. for 4 sections, tenderer should have 4 times capability required for one section.

### 3.4 System of Verification of Tenderer's Credentials:

- 3.4.1 The Tenderer shall submit online along with the tender document, documents in support of his/ their claim to fulfil the eligibility criteria as mentioned in the tender document. Each page of the copy of documents/ certificates in support of credentials, submitted by the tenderer, shall be Signed/ digitally signed by the Tenderer or authorized representative of the Tendering firm. Only those documents which are declared explicitly by the Tenderer as "Documents supporting the claim of qualifying the laid down eligibility criteria", will be considered for evaluating his/ their tender.
- 3.4.2 The Tenderer shall submit a notarized affidavit on a non-judicial stamp paper stating that they are not liable to be disqualified and all their statements/ documents submitted along-with bid are true and factual. Standard format of the affidavit to be submitted by the bidder is enclosed as Annexure-B-1. Non-submission of an affidavit by the bidder shall result in summary rejection of his/ their bid. And it shall be mandatory incumbent upon the Tenderer to identify, state and submit the supporting documents duly self-attested by which they/ he is qualifying the qualifying criteria mentioned in the Tender Document. It will not be obligatory on the part of the RailTel to scrutinize beyond the submitted document of the Tenderer as far as his qualification for the tender is concerned.
- 3.4.3 The RailTel reserve the right to verify all the statements, information and documents submitted by the bidder in his tender offer, and the bidder shall, when so required by the RailTel, make available all such information, evidence and documents as may be necessary for such verification. Any such verification or lack of such verification, by the RailTel shall not relieve the bidder of its obligations or liabilities here under nor will it affect any right of the RailTel thereunder.

- 3.4.4 In case of any wrong information submitted by the tenderer, the contract shall be terminated, Earnest money deposit (EMD) & Performance Guarantee (PG) of contract forfeited and agency barred for doing business with entire RailTel for 5 (five) years.



रेलटेल  
RAILTEL

RailTel Corporation of India Ltd.

(A Minorana Category - 1 Enterprise)

**(अनुलग्नक-B-1)- Offline Submission**

**FORMAT FOR AFFIDAVIT TO BE UPLOADED BY TENDERER ALONG WITH  
THE GeM BID DOCUMENTS**

(To be executed in presence of Public notary on non-judicial stamp paper of the value of Rs. 100/-. The paper has to be in the name of tenderer) \*\*

I..... (Name and designation) \*\* appointed as the attorney/authorized signatory of the tenderer (including its constituents),

M/s .....(hereinafter called the tenderer) for the purpose of the Tender documents for the work of .....as per the GeM Bid No..... of (RailTel Corporation of India Limited/Eastern Region), do hereby solemnly affirm state on the behalf of the tenderer including its constituents as under:

1. I/We the tenderer (s) am/are signing this document after carefully reading the contents.
2. I/we the tendered (s) also accept all the conditions of the tender and have signed all the pages in confirmation thereof.
3. I/we hereby declare that I/we have downloaded the tender documents from GeM portal. I/we have verified the content of the document from the website and there is no addition no deletion or no alternation to be content of the tender documents. In case of any discrepancy noticed at any stage i.e. evaluation of Tenders, execution of work or final payment of the contract, the master copy available with the RailTel administration shall be final and binding upon me/us.
4. I/we declare and clarify that I/we have not made any misleading or false representation in the forms, statements and attachments in proof of the qualification requirements.
5. **I/we also understand that my/our offer will be evaluated based on the documents/credentials submitted along with the offer and same shall be binding upon me/us.**
6. **I/we declare that information and documents submitted along with the tender by me/us are correct and I/we are fully responsible for the correctness of the information and documents, submitted by us.**
7. I/we undersigned that if the certificates regarding eligibility criteria submitted by us are found to be forged/false or incorrect at any time during the process for evaluation of tenders, it shall lead to forfeiture of the tender EMD (action as per Annexure-B-2 in case of firms claiming EMD exemptions) besides banning of business for five years on entire RailTel. Further, I/we (Insert name of the tenderer) \*\*

\_\_\_\_\_ and all my/our constituents understand that my/our constituents understand that my/our offer shall be summarily rejected.

8. I/we also understand that if the certificates submitted by us are found to be false/forged or incorrect at any time after the award of the contract, It will lead to termination of the contract, along with forfeiture of EMD/SD (action as per Annexure-B-2 for firms claiming EMD exemptions) and performance guarantee besides any other action provided in the contract including banning of business for 05 (five) years with entire RailTel.

DEPONENT  
SEAL AND SIGNATURE OF THE TENDERER

**VERIFICATION**

I/we above named tender do hereby solemnly affirm and verify that the contents of my/our above affidavit are true and correct. Nothing has been concealed and no part of it is false.

DEPONENT  
SEAL AND SIGNATURE OF THE TENDERER

Place:  
Dated:

\*\* The details as appropriate, are to be filled in suitably by tenderer. Attestation before Magistrate/Notary Public.

RailTel Corporation of India Ltd.

(A Ministry Category 1 Enterprise)

**FORMAT BID SECURITY DECLARATION**

(On Non-judicial stamp paper of Rs. 100/-)

Whereas, I/We..... (Name of Agency) has submitted bid for ..... (Name of Work and GeM Bid No. GEM/2026/B/\_\_\_\_\_) and whereas Earnest Money Deposit is being exempted in the aforesaid tender to give relief to the bidders as per Govt. of India guidelines as the bidder being .....

I/We hereby submit the following “Bid Security Declaration” in lieu of exemption from submitting Earnest Money Deposit: -

1) If I/We withdraw or modify my/our bid during the bid validity period (including extended validity of tender) specified in the tender documents;

Or

2) If, after the award of work, I/We fail to accept LOA/PO, or to sign the contract agreement or fail to submit performance guarantee Amount or fail to commence the work within stipulated time period prescribed in tender documents;

Or

3) If I/We furnish any incorrect or false statement/ information/ document;

Or

4) If I/We hide any relevant information or do not disclose any material fact in the tender;

I/We may be disqualified and banned for a period of three years and shall not be eligible to bid for future tenders in RailTel Corporation of India Ltd. for the period of three years from date of issue of such orders.

**(Signed by the Authorized Representative of Firm)**

Name of Authorized Representative:

Name of Firm:

Date:

**4. General Condition:**

The tenderer must have a proper office with Landline phone/FAX, Internet connection Computer, printer & Office staff etc. and provide Phone, Fax no. & E-mail ID in his credentials along with the submission of offer. Any change subsequently shall be advised in writing to this office.

**5. Validity of the Contract:**

The validity of the contract shall be 02 (two) Years from the date of taking up service contract after issue of LOA and shall be extendable by 01 (one) year on same rates, terms & conditions.

**In case of premature withdrawal (before the completion of the tenure agreed) of the Team by the contractor for any reason whatsoever, PBG amount shall be en-cashed. Also, in case the premature withdrawal is without at least one month's notice, additionally the maintenance charges for the last two months shall also be forfeited.**

**6. Tender Cost: Not Applicable**

7. The tenderer shall produce along with tender document, the documentary support for their experience. The tenderer shall also state the number of fully equipped teams, which shall be placed fully under the disposal of RailTel. Documentary support like cash memo/invoice/bill for the possession of vital equipment such as OTDR, Splicing Machine, Power meter, Cable route locator, Road Vehicle etc. shall be submitted along with the tender document.

8. All tenders must be accompanied by the Schedule of Rates attached as SOR-A, SOR-B duly filled in and signed/ digitally signed complete with technical details, unsigned tenders will not be accepted.

9. **EMD:** -A sum of Rs. 2% of total tender value (2% of estimated value of the tender subject to max Rs. 20 Lac for estimated value of Tender above 5 Lac and up to Rs. 20 crore) for respective tendered section should be deposited as earnest money in favour of RailTel Corporation of India Ltd. Eastern Region, Kolkata through net banking. No interest is allowed on this Deposit and RailTel Corporation reserves the right to forfeit this Deposit if the successful tenderer fails to submit the Performance Guarantee Amount by the terms and conditions of the tender. Tenders not accompanied by Earnest Money will be summarily rejected.

For multiple sections, the EMD amount will be 2%of total tender value (2% of estimated value of the tender subject to max Rs. 20 Lac for estimated value of Tender above 5 Lac and up to Rs. 20 crore)for the total number of sections which he has quoted.

**9.1** For NSIC registered firm/MSE: Please refer clause no. 5.8: Submission of Earnest Money Deposit (EMD) under instructions to tenderers and General Conditions of Contract.

10. The offer of Tenderers, who do not comply with the above conditions, will be rejected.
11. The RailTel reserves the right to accept / reject any tender in respect of whole or any portion of the items specified without assigning any reason whatsoever. RailTel also reserves the right to add or delete any maintenance section. In case of Addition/deletion of any section, the change in contract value will be governed as under:

**Change in Sectional length:**

+/- 0% to 55%                      -                      +/- ½ of %age of change in sectional length rounded off to nearest full %age.

12. **Material to be supplied by RailTel & Contractor:** The quoted rates in the schedule should include all the materials to be provided for the work to be done by the contractor as described in the tender document and the schedules attached. Tenderer's special attention is invited to the fact that no material shall be arranged /supplied by RailTel except OFC, HDPE Duct, Patch cord & 0/10/20 db connector/attenuator (as required) in various sections for Preventive Maintenance and fault rectification of OFC. All materials including the materials covered under the Schedule of Requirement and those required to achieve the end objective and any special protection materials needed are to be supplied by the contractor. The material used by contractor should be of approved quality specified.
13. **Unit Prices:** The prices quoted by the tenderers shall be as including GST price against SOR-A after taking all the relevant factors into consideration and these should be firm without any variation clauses. The rate of GST should also be mentioned as applicable. All other taxes including GST as payable under the law of the land will be borne by the bidders, while for SOR-B rates have been indicated by RailTel are excluding GST. RailTel shall not accept any liability for the same after award and acceptance of contract. However, the tenderer shall quote in GeM portal for SOR A rates only as per financial bid format given in chapter 7.
14. The teams shall be deployed within 21 days from the date of issue of Letter of Acceptance. If the tenderer fails to deploy the machineries and man power as per tender document, LOA shall be cancelled and EMD shall be forfeited (in case of firms claiming EMD exemption action to be taken as mentioned in the Annexure-B-2.)
15. **Validity:** The tenderer shall keep the offer open for a minimum period of 120 days from the date of opening of the tender within which period the tenderer cannot withdraw his offer. Any contravention of this condition will make tenderer liable for rejection and forfeiture of his Earnest Money deposit.
16. Before quoting, the Tenderers are advised to ascertain the nature of work involved and invariably undertake a site inspection.

17. Tenderer is required to quote for the complete work.
18. The submission of tender will be deemed to imply that this memorandum and all documents enclosed have been studied and understood and the tenderer is aware of the full scope of the work to be done and the conditions affecting the execution.
19. The tenderer shall not increase the quoted rates in case RailTel decides to negotiate for reduction in rates. Such negotiations shall not amount to cancellation or withdrawal of the original offer and the rates originally quoted will be binding on the tenderer.
20. If the tenderer deliberately gives wrong information in his/her tender or creates such circumstances for the acceptance of his/her tender, then RailTel reserves the right to reject such tender at any stage. In case credential certificate(s) submitted by the contractor are found to be incorrect, EMD shall be forfeited (in case of firms claiming EMD exemption action to be taken as mentioned in the Annexure-B-2.) in respective tenders he has quoted and he will be barred from quoting in RailTel tenders for a period of 03 (three) years.
21. **Performance Guarantee Amount (PG):** The successful tenderer shall submit a performance guarantee amounting to **5% of total contract value** (Basic amount plus GST) \*in the form of online transfer or irrevocable Bank Guarantee **issued from a Scheduled commercial bank (either private or PSU) but not from any Cooperative bank or NBFC**, within 30 days from the date of issue of LOA. **If the Contractor fails to submit the requisite PG even after 60 days from the date of issue of LOA, the contract is liable to be terminated**

\* Round off to nearest higher Rs. 1000/- (one thousand).

Extension of time for issuance & submission of PBG beyond 30 days from the date of issue of LOA may be granted subject to the conditions that a penal interest of 15 % per annum of the amount of BG shall be charged for the period of delay beyond 30 days i.e. from 31<sup>st</sup> day/date of issue of LOA till the date of issue of PBG. The PBG shall be initially valid up to stipulated date of completion of all contractual obligations including warranty obligations plus 90 days along with a claim period of 12 months (time period between expiry date and claim date) on top of guarantee period. PBG shall be released after satisfactorily completion of the work and on expiry of warranty. The Bank Guarantee should be issued & confirmed through SFMS (Structured Financial Messaging System).

The Instruments for Performance Guarantee should be valid for three months beyond the completion of warranty period (please refer clause 4.7 under introduction & clause No. 16 under special condition of contract).

**Note:**

- 1) A separate advice of the BG will invariably be sent by the BG issuing bank to the RailTel's Bank through SFMS and only after this the BG will become acceptable to RailTel. It is therefore in own interest of bidder to note RailTel's Bank IFSC code, its branch and address and advise these particulars to the BG issuing bank and request them to send advice of BG through SFMS to the RailTel's Bank.

Detail for online SFMS confirmation using the platform is as below:

BG advising message – IFN 760COV/ IFN 767COV via SFMS  
To mandatorily send the Cover message at the time of BG issuance.  
IFSC Code of ICICI Bank to be used (ICIC0000007).

Mention the unique reference (RAILTEL6103) in field 7037

- 2) Any performance Guarantee up to a value of Rs. 5 Lakhs is to be submitted through online transfer only.

RailTel' Bank Account Details for online transfer are given as under:

Bank: Union Bank of India,  
A/C No.: 401601010519491  
IFSC Code: UBIN0540161  
Branch: Camac Street Branch  
Address: 1/1, Camac Street, Ground Floor,  
Kolkata, West Bengal, PIN-700016

- 3) In case of submission of Performance Guarantee in form of FDR (More than 5 Lakhs), then lien should be created in favor of "RailTel Corporation of India Ltd.".
- 4) No interest shall be paid on the amount of earnest money and Performance Guarantee held by RailTel, at any stage.
- 5) The value of P.G. to be submitted by the contractor will not change for variation up to +25%(either increase or decrease).In case during the course of execution , value of contract increases by more than +25% of the original contract value , an additional performance guarantee amounting to 5% for the excess value over the original contract value shall be deposited by contractor OR the contractor has to submit performance guarantee of 5% of total revised value for further release of existing P.G. This clause is applicable in case of extension of maintenance contract.

**22. Security Deposit:** Not Applicable

**23.** The successful tenderer shall sign an agreement for the execution of the work as tendered by him/her and accepted by RailTel within 15 days after the receipt of notice from RailTel that such documents are ready.

**24.** The maximum number of sections that can be awarded to a contractor is 50% of the number of tendered sections, in case of odd number of tendered sections, number of sections to be awarded should be rounded off to higher side. This exercise will be

done at the time of evaluation of technical bid and the financial bid of thus disqualified bidders will not be opened.

- 25 a. No adjacent sections will be awarded to the same contractor to ensure redundancy of resources to maintain SLA. Adjacent sections of tendered sections are following:

Sl. No	Section HQ	Territory	Adjacent section HQ
1	Bhagalpur	NJP	Luckeesarai, Dumka, Mokama and Tinpahar

**If any contractor executing OFC Maintenance work/ participating in the adjacent sections, their bid will not be considered as eligible offer.**

- 25 b. For awarding of contracts, maximum 30% (rounded to next higher No.) capping will be applicable in each territory. Same vendor will be awarded maximum 30% of total contractual teams (excluding temporary and extended) in a particular Territory. Territories of tendered sections are mentioned in above table under clause no 25 a.

26. **The Bid evaluation Method for multiple section tenders:**

In order assess the capability of a contractor to execute simultaneous OFC maintenance work in multiple sections efficiently, the following evaluation process will be adopted:

1. In case of multiple tenders for OFC maintenance floated together, the tenders will be finalized serially.
2. In case a bidder participating in multiple section OFC Maintenance Tender floated with a single tender document, the following criteria will be applicable:
  - a. Maximum 50% of Tenders will be awarded to a single bidder as detailed in clause no.24.
  - b. The bidder is not eligible to participate in any adjacent section where he is executing OFC maintenance work (please see the note below) or participated in the current tendering process, if bid submitted in the adjacent sections by any bidder, it will not be considered for evaluation.
  - c. For example, for a multiple section tender of 5 sections, a bidder can be awarded maximum 3 sections which are not adjacent to one another and not adjacent to the sections where the contractor is executing OFC maintenance work.

**Note:** Maintenance teams deployed temporarily or working on extension beyond the contract period (2+1 or 3+1 year) will not be considered as adjacent maintenance team.

3. The tenderer can bid for any number of sections. However their bid shall be considered for evaluation in all such sections only if it meets **required** technical and financial eligibility criteria cumulatively.

For example if a vendor participating in 5 tenderer sections, the required eligibility criteria will be as follows:

**Technical eligibility will be** – Performed OFC route maintenance for 5 x more than 150 km. section of continuous stretch.

**For startup:** Performed OFC route maintenance for 5 x more than 60 km. section of continuous stretch

OR

Should have executed 5 works of each for trenching, laying, splicing and termination of OFC for a continuous stretch of 50 km. in a single contract (50 km. x 5) or a combined length of minimum (200 km. x 5) in the past three financial years & current year before the date of opening of tender.

**For start-up :**

Should have executed 5 works of each for trenching, laying, splicing and termination of OFC for a continuous stretch of 20 km. in a single contract (20 km. x 5) or a combined length of minimum (80 km. x 5) in the past three financial years & current year before the date of opening of tender.

**Financial eligibility will be as** - The tenderer must have received total contract value of 150 % of the total advertised value of five sections being participated. in the past three financial years & current year before the date of opening of tender.

**For start-up :**

**Financial eligibility will be** - The tenderer must have received total contract value of 50 % of the advertised value of five sections being participated, in the past three financial years & current year before the date of opening of tender.

27. **In case, if there is any contradiction between GeM Terms & Conditions (GeM GTC & SLA) and RailTel's Bid Specific Additional Terms & Conditions (Given in Tender Document); RailTel's Bid Specific Additional Terms & Conditions (Given in Tender Document) shall prevail.**

## **Chapter- 5**

### **INTRODUCTION**

#### **INFRASTRUCTURE:**

1. RailTel has exclusive Right of Way along the Railway track. RailTel has built over 50,000 Kms length of OFC route along the ROW and access network in cities on which different transmission equipment, data network equipment etc have been deployed.
  - 1.1 Armored OF Cable has been laid along the route is provided with HDPE/GI/RCC protection wherever required for Track Crossing, Road Crossing, LC gates etc. The contractor shall accept the site on as-is-where-is basis. The maintenance agency is not only responsible for the proper maintenance of backbone UG/Over Head OFC laid between node to node but also the access OFC network laid in cities (up to around 15% of total section length) . The agency is fully responsible for the end to end performance between the two nodes in the entire jurisdiction of the teams reach awarded.
  - 1.2 The RailTel has DWDM, STM telecom equipments, Power plant, DG sets, AC machine, earthing etc in POPs on OFC network.
  - 1.3 RailTel has Wi-Fi related assets like Fiber, Switches, UPS, Battery, APs, LAN, Power Cables etc at some Railway stations in the section.

#### **2. SCOPE OF WORK:**

- 2.1 The CONTRACTOR shall be responsible for the maintenance of the OFC network awarded to him. This shall include but not limited to undertake all required preventive measures of the OFC route, rectification of faults and restoration jobs required for achieving the OFC link availability of highest order.
- 2.2 The contractor shall carry out any OFC related works like attending to existing protection works, splicing, termination, tightening of nuts/bolts, provision of complete clamps for supporting the already done protection work over culverts/bridges, wiring of equipment as directed by the Engineer of the section. No additional payment will be made on account of these technical works.
- 2.3 The contractor shall also carry out other miscellaneous works such as proper up keep of Telecom equipment, power plant, DG sets, Air Conditioners, minor repairing of shelters/building, Wi-Fi equipments, Earthing arrangements general cleanliness of the RailTel's POP, and other such activity as advised by Engineer of the section on

- periodical basis. In case of replacement or repair of any spares or parts of any equipment, payment for the same will be reimbursed to contractor on actual basis.
- 2.4 The maintenance contract is planned to be awarded for a period of 2 years and extendable by one year on same terms & conditions. However, the contract can be terminated by giving 30 days' notice before the expiry of contractual completion period in case performance of the contractor is not found satisfactory or as and when required by RailTel.
- 2.5 **Preventive Maintenance for Cable Protection:**
- 2.5.1 Regular patrolling and surveillance of OFC route to have pro-active check to prevent OFC link disruptions. It will be done by dedicated and exclusive team who will not be assigned any other work. There should be at least one patrolman on approximately every 50-60 kms beat and between two Long Haul PoPs (also located at approximate length of 50-60 Km). Each patrolman has to be equipped with a mobile phone. Suitability of patrol man shall be examined by Engineer before deployment.
- 2.5.2 Patrolling of the entire section has to be done by way of 'Window Inspection' from passenger train and the entire section has to be covered at least thrice a week during daytime. If any activity is observed which may affect the OFC, the patrolling team should get down and reach the suspected spot by foot or by any means and prevent any damage to the OFC. The matter must be reported to the RailTel officials immediately. The time-to-time movement of the patrolling team shall be kept informed on daily basis so that they can be contacted during emergencies.
- 2.5.3 Part of the team shall also go on foot/bi-cycle along the entire route so that minimum two block sections on every day is covered and observe the condition of the OFC. It is expected that the entire section under the contract will be covered by foot patrolling at least 3 times every month. Therefore, for effective patrolling of the entire section by passenger train as well as by foot/bi-cycle, as above, sufficient number of persons are to be engaged by the contractor. Monitoring of jobs undertaken by other agencies in the vicinity of RailTel's fiber network to ensure the safety of RailTel's OFC cable shall also be done by assigned agents of the contractor.
- 2.5.4 Attending to / safe-guarding against any signs of damage or potential damage of RailTel's OFC network, which come to light during patrolling.
- 2.5.5 Collecting information & accordingly coordinate with other agencies before the execution of work, who shall carry out any work in the vicinity of RailTel's OFC route, to safe-guard against the damages to RailTel's OFC cable. The contractor shall effectively co-ordinate with other agencies working along the RailTel's OFC route to prevent damage to OFC link and the contractor will be held responsible for any cut of the link by other agencies.
- 2.5.6 Liaisoning also shall be maintained with other department like NHAI, Municipal corporations, Nagar palikas, Rlys, Urban Development Authorities etc regarding the permission being given or shall be given to other parties for any type of construction

works along the RailTel OFC route. Regular Liaisoning with various Railway authorities like Railway field officials of Engineering, S & T and Electrical department and protect the OFC when any of these departments do work, which may directly or indirectly affect the OFC in the section. However, only cost of the material (JC and JE), may be reimbursed at SOR-B rates by RailTel for rectification of cuts during large scale Railway/NHAI works in all the O&M contracts with the approval of ED/Region. Penalty for not providing JC then shall be Rs. 9,080/- per JC (Excl. GST). For all other cases it shall be equal to the penalty proposed in Annexure "E".

- 2.5.7 Additional patrolmen, if required for gauge conversion/ doubling works / continuous construction works shall be deputed by the contractor including day-to-day open line works of railway such as track works, bridge works and sleeper works etc.

**2.6 Planned repairs to existing joints/Terminations:**

The preventive maintenance should be carried out with prior approval and during planned shutdown period generally during night time between 00:00 to 05:00 hrs. The additional shutdown is not guaranteed, as number of customer circuits will be in operation.

- 2.6.1 Contractor shall also carry out testing of existing joints and OFC repairs along with testing of OFC route for improvement in the performance with link margin as per national/international standards and instruction of Engineer with consumable material such as repair kit etc. No extra charges will be payable for this schedule maintenance except maintenance charges as per SOR-A. However, for attending OFC joint / termination and laying of cable etc as the case may be for improvement of fibres which was identified as high loss / break / defective (at the time of taken over of the section) payment will be made as per SOR – B rates.

**2.6.2 Preventive maintenance of OFC cable:**

All measurements for preventive maintenance shall be carried out as per prior agreed time schedule. The testing of all fibers including short haul fibers shall be done, once in every four months for all sections and reports shall be submitted along with alternate bi-monthly bill. Any defects observed in the OF cable or in any of the associated equipment shall be attended at site. RailTel's maintenance supervisor will also accompany the teams as and when required. Testing should be supervised by the Engineer. Working fibers will be tested as per the instructions of engineer. OTDR testing report in proforma 1 & 2 will be submitted within 10 days of doing the measurements.

- 2.6.3 Testing consists of OTDR testing and Power Meter reading of all fibers for proving one to one correspondence. Station to station testing is required for spare fibers terminated at block stations in both the directions. Run through fibers may be tested from end to end only. The periodicity of testing is once in four months for all block sections.

- 2.6.4 **Reports:** Reports consists of (a) Section-wise tabulation of all fiber events reported by OTDR of more than 0.2 dB over the section fiber wise for all fibers tested in the given Performa in print and in Excel worksheet, (b) Tabulation of power loss from

A-B & B-A direction, average and loss per km at 1550 for all the fibers tested. The OTDR traces should be submitted in soft copy format.

- 2.6.5 In a situation, where in the vicinity of RailTel's OFC network any major construction / doubling projects are going on or are to start and necessitates re-routing through a new safe route of OFC to avoid damage, Contractor shall explore feasibility of alternate routes & provide detailed route plan for new location, where re-routing can be done.
- 2.6.6 Block section-wise condition of fibers is to be plotted using following color codes. Soft copy of the report to be submitted in hard & soft copy along with Bi-monthly bill.

- a. Broken and non-usable high loss fibers-----**RED**
- b. High loss fibers but usable in case of emergency-----**PINK**
- c. Working fibers-----**GREEN**
- d. Spare usable fibers-----**YELLOW**

Summary of fiber condition should be provided in the Performa attached.

## 2.7 Equipment/other fault restoration Services:

- 2.7.1 The contractor shall facilitate Engineer rectification of any other type of fault (equipment/ power plant etc) & shall be available with maintenance team & transport etc for going to the section.
- 2.7.2 Head Quarter of Maintenance Teams to be stationed at the designated Head quarters given in Annexure-A or at any other place mutually agreed to. The Maintenance teams shall comprise of manpower, logistics, required Tools/Plants/Machinery, equipments and sufficient fund to meet day to day expenditures, etc.
- 2.7.3 On all working days the members of team with team equipments should be present in office of the Engineer during office period unless team is assigned work in the section. The movement of team members should be in the knowledge of Engineer responsible for O&M of the section. The attendance of all team members shall be marked in the Performa accordingly. Daily diary of the works and movement of all staff shall be submitted along with the bill duly verified by the Engineer responsible for O&M of the section.
- 2.7.4 **Scope of maintenance:** Identification of OFC fault/cut on ground, obtaining permission from local authorities if required, excavation of earth to expose cable, laying of required length of OFC with protection wherever required, splicing of OFC, installation of Jointing pit (FRP/RCC chamber)& back filling of pit (FRP/RCC chamber)with Sand, minor repairing of shelters/building like leakage etc, provision/alignment/tightening of clamps and maintenance of GI pipes and troughs on bridges, supply and installation of cable Route Markers of RCC/FRP make and

Joint Markers as per specification, testing of OFC and updating of OFC as-built drawings etc. Cable route plan will be up-dated with each instance of cut, including date, cable location etc. Up-dated copies of relevant sheets of ABD (As built drawing) will be submitted along with bi-monthly bill. Updated drawing of whole section will be submitted in soft copy every 6 months & hard copy every year.

## **2.8 Restoration for OFC cuts:**

Under OFC link cut condition, the following activities shall have to be taken up by the CONTRACTOR for the restoration of OFC cut fault for the end-to-end restoration of the network traffic/service:

- 2.8.1 On receipt of information of fault in OFC the team stationed at the team HQ shall move immediately for locating and rectifying fault as per the response time given below. The working fibers shall be restored first. Sufficient labour shall be engaged for speedy restoration. Adequate care shall be taken not to damage QUAD copper cable of Railways if laid in the same trench.
- 2.8.2 For the identification of exact fault location on immediate basis, the OTDR measurement of spare fibre shall be made from the nearest telecom station/Node. For better clarity, the OTDR measurement on spare fiber shall be taken at Nodes / nearest OFC joints situated at both ends of cut and using dummy fiber spool of 1km, in case required.
- 2.8.3 After the OTDR measurement, the as-built drawing shall be referred and the physical site of fault on ground shall be located. It may be possible that data in as-built document may not be correct for the accuracy purpose, as such As-built drawing shall be taken as reference only. No claim of contractor will be entertained on account of the inaccuracy of the as built drawing. Accordingly, locating the OFC fault, the job of excavation in all types of soil, identification of OFC, pulling of cable from both ends if feasible, construction of jointing pits, splicing of OFC, back filling of trench & jointing-pit shall be taken up as per the standard procedure. Further, FRP /RCC marker at the jointing pit has to be provided for identification of route as well as jointing pit, depth of cable etc (Date of installing Jointing pits to be updated on route plan). This should be incorporated in the cable route plan also with accurate offset and depth recorded. The splicing of fibers are to be carried out in line with the installed fiber i.e. G.652 and measurements are to be taken on spare fibers. In case the active fibers are to be used, precautions are to be taken with regard to the power launched on to the fiber. Restoration of site shall be done to the entire satisfaction of the Engineer.
- 2.8.4 In case of OFC cut where it is not possible to pull the cable from either end, the contractor has to make two pits/ splicing joints required length of OFC supplied by RailTel has to be put in between two joints. The spacing of joints/ pits shall be depending up on situation at site and shall be as decided by Engineer. Remaining OFC has to be coiled in both the pits. Further, joint FRP/RCC markers at each

jointing pit have to be provided for identification of route as well as jointing pit. The precise joint locations so provided should be incorporated in the cable route plan also.

- 2.8.5 After the completion of site activities, the CONTRACTOR shall ensure the restoration of the traffic from the Network Operations Center (NOC) and there after fresh OTDR measurement & traces (at 1550nm) shall be taken for all spare fibers & submitted to RailTel.
- 2.8.6 After the completion of site activities & hop test, the As-built drawing shall be updated by incorporating the new details like OFC loop used, Joint-pit location, offset and depth of cable etc. Position of OFC should be shown from the center of the nearest track in as built drawing and the length of loop in joint pit after fault restoration shall be incorporated in as built drawings. The updated final as built drawings of cable route plans in soft and hard copies shall be made available to Railtel after end of contract period.
- 2.8.7 After attending the fault & permanent restoration a Fault-Rectification report, jointly signed by RailTel & CONTRACTOR, shall be generated for the closure of the complaint.
- 2.8.8 Any other job required for the restoration of the OFC fault/cut in totality is to be taken up by the Contractor.
- 2.8.9 In case the site condition is not favorable for the immediate permanent restoration of the fault, the temporary restoration of the service fibers shall be taken up immediately with the approval of Engineer. Permanent restoration work will not be considered in breakdown time unless there is again link break during restoration job. Permanent restoration of joint is to be carried out by contractor within 48 hrs from time of fault /OFC cut. In case the site is not conducive for permanent restoration some arrangement of manpower has to be done by contractor for safeguarding exposed OFC till permanent restoration. No extra payment shall be given to contractor on account of deployment of additional manpower to attend the cut. In case of further cuts at exposed OFC location contractor will be accountable for this additional downtime of OFC link.
- 2.8.10 OFC issued by RailTel to the contractor for use at OFC fault locations should be checked & tested before use at site.
- 2.8.11 It is mandatory for the contractors to install the jointing chambers and joint markers of RCC/FRP type after permanent restoration is done and should therefore keep adequate spare stock. The contractor shall keep minimum two nos. of jointing pit during the failure/cuts.
- 2.8.12 In case of any breakdown in the access network/last mile connectivity, Contractor shall be responsible for obtaining approval at his own cost from statutory authorities like Municipal Corporation, Development Authorities, Electricity Department

- PWD, NHAI and any other concerned authority as required for carrying out the repair.
- 2.8.13 Drains, pipes, cables, overhead wires and similar services encountered in the course of the works shall be guarded by the contractor at his own cost, so that they may continue in full and uninterrupted use to the satisfaction of the owners thereof.
- 2.8.14 Should any damage be done by the CONTRACTOR to any AC Power mains, utility pipelines cables or lines (whether above or below ground etc) whether or not shown on the drawings, the CONTRACTOR must make good or bear the cost of making good the same without delay to the satisfaction of the Engineer.
- 2.8.15 CONTRACTOR shall observe in addition to Codes specified in respective specification all national and local laws, ordinances, rules and regulations and requirements pertaining to the WORK and shall be responsible for extra costs arising from violations of the same.
- 2.8.16 CONTRACTOR shall have at all times during the performance of the WORK, a competent supervisor on the site. Any instruction given to such Supervisor shall be considered as having been given to the CONTRACTOR.
- 2.8.17 The CONTRACTOR shall employ as many personnel as required to comply with the local rules and administrative orders governing the Working Hours of Employment the contractor shall be responsible for compliance with all statutory requirements including personnel related matters.
- 2.8.18 **Night Work:** The contractor shall also work during night time and is required to complete the work in all respects within the stipulated time. Sufficient lighting arrangements and precautionary steps shall be provided to safeguard the workmen, public and the Railway assets and to afford adequate facilities for properly placing and inspecting the material and the work when the night work is in progress.
- 2.8.19 The minimum down time shall include time taken in restoration of fault/cut caused by any means like miscreant activity at day or night, due to work done by Railway or any other organization, due to development of high losses / break at existing joints, fault caused due to rodent, ant etc.
- 2.8.20 In case of partial damage of the cable or development of high loss in the working and spare fibre or cable cut at any time (day/night) by miscreants or by any agency, the responsibility of repairing the defective fibre lies with the contractor and included in the Schedule of Rate (SOR) - A.
- 2.8.21 In case contractor fails to complete the restoration of link (as per original condition) or submit OTDR & test records to establish completion of work a penalty as given in the tender document shall be recovered in addition to the recovery of amount

spent by RailTel in restoration the link as per SOR B rate of the work involved at site.

- 2.8.22 In no case the Engineer shall be held responsible for the delay in restoration except for the instance of making availability of OFC (if required) for restoration.
- 2.8.23 In the event of urgency, the team has to move to adjacent section, if desired by RailTel. The payment for actual work done, including transportation, will be made as per relevant items of SOR”B”.
- 2.8.24 **Examination of Finished Work:**

When finished work is taken down for the purpose of inspection for any reason, the contractor shall bear the entire expenses incidental there to in the event that the said work is found to be defective. This situation may be applicable to both planned work as also to emergency restoration.

**2.9 Mean-Time-To-Restore fibre cuts (MTTR) & Quality of work:**

- 2.9.1 **Response Time:** The maximum response time is 15 minutes from the time RailTel informs the team about the failure. Within this time the maintenance team should move towards the location of fault.

**Restoration Time:**

- a) The maximum restoration time is response time plus travel time including time for localization and restoration. In any case, the restoration period including excavation & splicing should not exceed six hours wherever easy approach roads are available and it should not exceed eight hours in rural and remote areas where approach roads are difficult.
- b) In the sections where cable has been laid by HDD method and immediate restoration in 8 hrs is not possible, the maintenance contractor has to arrange:
- i) Restoration of link within 24 hrs by drawl of overhead fibre between the adjacent pits to bypass the defective/faulty sub section.
  - ii) Guarding of overhead section till permanent restoration of cable laid by HDD Method.
  - iii) Restoration of cable laid by HDD method within 30 days.
    - No down time will be considered for failure of cable in HDD section. However, this is subject to lying of the overhead OFC to restore the link within 8 hours of the failure taking place.
    - However, down time of overhead fibre once drawn for temporary restoration of HDD section, will be considered while calculating the down time for entire billing period.

- c) In case CRT exceeds the prescribed restoration time for the section (6/8 Hrs. for Backbone Network, 8 Hrs. for Access Network (O/H) and 8 Hrs. for Access Network (HDD) on Bi-monthly) penalty for Hours exceeding the CRT shall be imposed as defined in tender document.

**2.9.2 Record of Fault Repair Time:**

Time taken by the Contractor from the time of lodging the complaint to the representative of Contractor at their designated office/Head Quarter plus 10 minutes (10 minutes being taken as the lead time for conveying the failure information to the OFC Maintenance Contractor) up to the time of restoration of end-to-end traffic after rectification of OFC cut(s)/fault(s) including the traveling time. The Repair time of any fault occurred shall be calculated by collecting data from respective NOCs of RAILTEL. After restoration of the link, a fault report is to be generated by contractor and obtained joint signature with RAILTEL engineer for records. Any pending restoration of link on account of RailTel shall be certified by Engineer and should not be counted in outage time.

- 2.9.3 If the splice loss of all the fibers are not within the prescribed limit, the contractor has to re-do the splice till the value is achieved failing which RailTel will carry out the work by itself deducting a defined penalty per fault from the monthly bill. If any failure/fault occurs in the rectification work done by the contractor within twelve months from rectification and beyond the validity of contract, due to defective workmanship/supply, the cost of material under warranty found defective will be recovered from contractor's dues/deposit available with RailTel.

- 2.9.4 During the maintenance or fault rectification work, should any damage occur to the Railway QUAD and other cables, contractor is liable to pay compensation as demanded by the Railway authorities.

**2.10 Monitoring & maintenance at equipment locations:**

The supervisor with maintenance team shall carry out preventive maintenance of each STM 64/16/4-1/DWDM long haul node (4-5 per section) once in 15 days. During every visit to the stations for measurements, the contractor staff shall monitor the condition of the electronic/electrical equipment installed for any alarms, order wire, battery voltage.

Periodic watering of earths shall be carried out. Cabling and wiring etc. shall be neatly dressed up.

The equipment shall be cleaned with blower/vacuum cleaner & Engineer assisted for all O&M activities and new equipment installations & advise the status to nominated RailTel Officials. The building/pre-fab housing the equipment's and its surroundings shall be kept clean & tidy by the contractor. In case any discrepancies are observed, the matter should be brought to the notice of the RailTel's Engineer.

- 2.10.1 The contractor will also check the functioning of Power Plant , Air conditioners and DG sets in the RailTel POP and report immediately to Engineer in case of defect or if the temperature at the POP is high. Minor repairs to the Shelter /Building/POP like Water proof sealing of shelter, repair to DOOR handles, WINDOW/DOOR PACKING etc will also be carried out by the contractor without any additional payment.
- 2.10.2 The contractor will test the working of diesel generator by running it for 30 minutes once in a month on load. After monitoring the condition of Diesel Generator (DG set) if filling up of lube oil and or diesel oil is required, the contractor will arrange the same from the nearest petrol pump/depot approved by the Engineer. The cost of lube oil/diesel oil will be reimbursed by RailTel as per actual on production of the receipt. In addition to it, 5% payment will be made towards cartage charges. Consumption of Diesel oil shall be verified based on the hour meter reading provided on the diesel generator. The Engineer in the sections has to maintain a register to keep record of time of failure of electricity, start time and off time of D.G. set, total running hours of DG set etc.

The contractor shall ensure attention to electrical problems associated with 230 V AC supply. The cost of material used in the rectification will be reimbursed as verified from site of work.

- 2.10.3 Contractor shall also carry out wiring and installation of associated fittings etc. for extending data circuits to customer or as advised by Engineer as and when required, utilizing existing man power resources. Accordingly one technician shall be available in the maintenance team, trained in this type of work. All required material shall be made available by RailTel.

## **2.11 Maintenance Plan:**

The Tenderer as part of his Tender has to submit a detailed plan for the maintenance of the network including the details of the man-power and equipments proposed to be located at different sites to cover the jurisdiction as described in "Annexure-C (a, b & c)", the communication facilities, the planned maintenance bases and the detailed plans to fulfill the tender conditions.

- 2.11.1 The CONTRACTOR shall submit the list of manpower, machines, equipments and consumable items with quantities suitable to meet the contractual requirements for the jurisdiction described elsewhere in the tender document along with the Tender and make available resources to RailTel officials for inspection, maintenance and corrective measures as and when required.
- 2.11.2 Entry pass shall be issued to the representatives of the contractor by RAILTEL from the respective maintenance stations for handling all maintenance work in Railway area.

- 2.11.3 Submission of monthly & emergency report as desired by Engineer in the Performa specified by RailTel will also be a part of maintenance contract.
- 2.11.4 Supply of OFC, HDPE duct and other accessories:** For making good of any break/loss/cut in fiber only OFC, HDPE Duct, Patch cord & 0/10/20 dB connector/attenuator shall be supplied by RailTel to the contractor at the nearest RailTel depot or designated/ nominated stores. All other materials including splicing enclosures shall be arranged by contractor including Joint enclosure, Joint chamber and route marker of RCC/FRP free of cost. The material shall be picked up by the contractor in advance from nearest RailTel's depot and shall be accounted with reference to the specific incidence of fiber cuts. The transportation cost on differential distance from nominated stores shall be arranged by RailTel, if applicable.
- 2.12 Supply of consumables/items like Joint enclosure, FRP Jointing pit, Complete Clamps for holding pipe over bridges/culverts etc meeting the specifications as detailed under the Technical specification of the tender document shall be done only after approval of TM. Contractor has to keep stock of above items up to the satisfaction of Engineer.
- 2.12.1 The material issued to the contractor and remaining unutilized after completion of the job shall be returned back to RailTel's designated stores at the end of contract period. A monthly material statement shall be submitted to the Engineer by the contractor.
- 2.12.2 Wherever new joint is provided or existing joint is attended for rectification during the maintenance period, joint shall be properly buried with its top cover being at least 0.6 mtrs below the ground level.
- 2.12.3 Quarterly meeting with EIC along with Engineer and Supervisor/Maintenance team contractor shall be mandatory to assess the progress of work and for pin-pointing the constraints to ensure the quality and speed of preventive/ protective maintenance work.
- 2.13 **Taking over the section for maintenance:**
- a) There should be a proper handing over/taking over of outgoing and incoming contractor. The fiber parameters should be at least as good as or better than these were at the time of taking over the sections by outgoing maintenance team.
  - b) The contractor shall complete the OTDR measurement (& power measurements to find out criss-cross of fibers) of all the block sections for all the fibers and submit a joint statement duly signed by the contractor and RailTel's Engineer indicating the faults to be attended for making good of all the non-working fibers. This process shall be completed within 90 days from the date of deployment. As one-time drive, all criss-crossing of fiber to be got removed by the contractor to save downtime during failure rectification. This will be done in close co-ordination with Engineer of RailTel.

- c) The Engineer shall also advise the contractor of the faults to be attended to make the fibers good at the cost of RailTel. A separate work Order will be issued by RailTel for such work. This shall be completed in 90 days from the date of advice by RailTel. The payments of the above work will be carried out as per SOR B rates given in the tender.
- d) In case the contractor fails to submit the joint report indicating the faults, criss- crossing the fibers to be attended within 45 days from the date of Deployment of team, a defined penalty will be imposed.
- e) Maintenance of all the fibers shall be the sole responsibility of the contractor.
- f) On completion of the contract, the OTDR measurement shall be carried out on all spare fibers to ascertain the condition of cable, which should be same or better than the condition of the cable taken over by the contract at the beginning of the contract period. In case there is an increase in the number of fiber events at the time of handling over vis-à-vis the number of events at the time of taking over (events/faults more than .5 db), the cost of rectification will be deducted from the final bill of the outgoing team as per the SOR-B rates, the security amount held may also be forfeited. Besides this, OFC route drawings handed over to the contractor at the time of award of work shall be updated fully and submitted to RailTel, both in Hard and Soft copy as given by RailTel incorporating the various changes occurred during the contract period. No dues certificate shall be submitted by the contractor at the time of final bill for SOR-A and SOR-B.
- g) On the advice of RailTel, Tenderer will arrange the separate rectification team
- h) for rectification of all the OFC faults and make the fiber good without affecting the regular maintenance as per the scope of work.

#### **2.14 SOR B Items & Methodology for Operating:**

Beside regular maintenance the Contractor has to work for improvement of fibre and for Cable route strengthening work under “SOR – B”, as and when communicated by authorized representative of RailTel in writing. The SOR for respective items to be executed in Schedule- B which are enclosed to this tender document. Along with the items the rate for each item is also indicated. If the items are executed, the contractor shall be paid as per rate indicated in Schedule-B.

- a. Engineer of the section shall prepare the estimate for faults to be attended as per 2.13b above, get the approval of the Competent Authority of RailTel and advise the contractor, in writing, to carry out the work.
- b. Separate work order shall be issued for each rectification works (as per clause 2.13 & 2.14) to the contractor (successful tenderer) as per SOR-B rates given in tender document.

- c. Completion period will be specified in work orders as per site condition & nature of urgency.
- d. In the event of failure of Contractor to complete the work within 90 days from the date of issue of such order, Penalty will be imposed as per rule and the work will be entrusted to outside agency, implication if any, arising due to execution of the work by outside agency will have to be borne by the CONTRACTOR i.e.no claim for compensation will be entertained. In case of repeated failure to take up SOR-B work, contractor can be terminated.

### **3. CONDITIONS OF CONTRACT**

- 3.1 The CONTRACTOR may quote for one or more OFC sections under jurisdictions described in "Annexure-C".
- 3.2 Before quoting, it is advisable that the prospective Tenderer shall make themselves fully conversant with the locations, OFC routes and types of jobs in details to be carried out therein as per the tender requirement, so that they clearly understand the scope of work and assess the requirement of resources to complete the work in scheduled time.
- 3.3 The CONTRACTOR is deemed to have understood the conditions of existing OFC routes like terrains, various crossings, access details, on-route RailTel's maintenance bases etc., by visiting the sites and collecting first hand information before submission of the offer. In case of any doubt, the clarification may be taken from the RailTel before submission of the offer.
- 3.4 The Contractor shall be totally responsible for the successful execution of the OFC route maintenance contract.
- 3.5 The contractor shall not sub-contract whole or any part of the work.
- 3.6 The data provided in the Tender document shall be used by the Tenderer for reference and information purpose only. It shall be the Tenderer's responsibility to verify the data & satisfy himself in regard to accuracy of data.
- 3.7 The CONTRACTOR shall be responsible for making an arrangement at each maintenance station for excavation works, testing, measuring, splicing equipments, unskilled/skilled manpower, transport facilities for their teams & other logistic supports required to maintain end-to-end OFC connectivity in physical layer as per the contract.
- 3.8 The responsibility of the CONTRACTOR shall include provision of preventive measures of OFC routes to avoid damage and cut, deployment of manpower, supply of required materials, erection, installation, testing, documentation, including the related civil works necessary for ensuring the complete end-to-end OFC connectivity in physical layer as described in the tender document at no extra cost to RailTel.

- 3.9 The material used & workmanship shall satisfy the applicable standard Specifications.
- 3.10 RailTel shall be entitled to reject the goods, materials and work executed by the contractor, which may not be conforming to the specifications within a reasonable time of installation of the said goods and materials and charge the contractor for all expenses direct and consequential, incurred thereby.
- 3.11 Where it is mentioned in the specifications that the CONTRACTOR shall perform certain work for completing the job in totality, it is to be understood that the contractor shall do so at his own cost and contract price shall be deemed to have included cost of such performances and provisions so mentioned.
- 1.12 The Contractor to provide Two sets (02) of cotton uniform (Pant and Shirt set) in grey colour of 220 GSM (with RailTel logo in both front and back) including two nos (02) florescent green safety jackets (with RailTel logo in both front and back) with safety appliances like: dust masks, safety belt, safety shoes, helmet, hand gloves, safety goggles, rain gears etc to all the deployed man power within 30 days of joining of maintenance team. Two sets of uniform with florescent green safety jacket to be provided once in a year. Failing which penalty will be imposed as “Rs. 200 (excl GST) per person per day” and deduction will be started from the initial bill.

It is to be noted that RailTel Logo should be embroidered properly in each of the dress and safety jacket of team members. Details should be maintained as specified below:

Sl. No	Uniform description	Logo dimension to be maintained	To be embroidered on
1	Grey color dress	5”wide& 5” tall	Left sleeve of uniform
2	Florescent green safety jackets	i) 5” wide & 5” tall for front side ii) 8” wide & 8” tall for back side	i) in front, logo to be embroidered in Left Chest ii) in back, logo to be embroidered in Upper Back Centre

RailTel logo color and style should be exactly same as shown in RCIL’s letterhead.

- 3.13 During any construction work in public places, all precautionary caution boards, barricading sheets as per standard laws & rules to be used by the Contractor.
- 3.14 During the course of execution of the work, if any discrepancy or inconsistency, error or omission in any of the provisions of the contract is discovered which needs to be clarified, the matter shall be referred to Regional General Manager/RailTel who shall give his decision in the matter and his decision shall be final and conclusive.

- 3.15 The contractor should ensure that the team employed by him shall not move or trespass to areas other than the site(s) required for the execution of the work. Under no circumstances the Contractor should infringe and carry out the work which hampers the Operations and Safety of the Railways, train movements and damage Railway assets. The contractor is responsible for the safety of team members while executing the work in the Railway areas.
- 3.16 The Contractor shall submit along with the offer the list of the number of personnel who will be available permanently for the maintenance works of RailTel. This should include details of technical qualification & minimum experience.
- 3.17 The work is subject to inspection at all times by RailTel officials. The CONTRACTOR shall carry out all instructions given to him or his representatives during inspection.
- 3.18 Any work not conforming to the execution plans, standard specification codes or engineering practice shall be rectified by the CONTRACTOR at his own cost.
- 3.19 Inspection and acceptance of the work shall not relieve the CONTRACTOR from any of his responsibilities under this contract.
- 3.20 The CONTRACTOR shall provide the complete details of planning for items/materials, test/measuring instruments, tools/tackles & manpower to be deployed for the jurisdiction as mentioned in Annexure-C and D with the offer.
- 3.21 The CONTRACTOR shall observe in addition to codes specified in respective specification, all national and local laws, ordinances, rules and regulations and requirements pertaining to work and shall be responsible for any extra costs arising from violations of the same, which shall be borne by the Contractor.
- 3.22 By entering into the maintenance contract with RailTel, the contractor shall agree to maintain the secrecy of all documents/information/drawings etc provided by RailTel during the period of contract and shall handover all the documents back to the RailTel immediately after the termination of the contract.
- 3.23 In case Engineer feels that the contractor is not able to execute the work to the satisfaction of RailTel, RailTel shall at its own discretion can engage other agencies for that incident to ensure the smooth execution of the job at the risk and cost of the contractor, after duly informing him telephonically or through SMS, followed up by a letter.
- 3.24 The CONTRACTOR shall be solely responsible for making available for executing the work, all-requisite construction equipment, special aids, tools, plants and testing equipment and appliances. Such construction equipment etc. shall be subject to examination by RailTel for approval for the same. Any discrepancies pointed out by

the RailTel shall be immediately got rectified, repaired or the equipment replaced altogether, by the CONTRACTOR.

- 3.25 The representative of the CONTRACTOR shall take care for not to tamper with the RailTel's installed equipments in the RailTel premises.
- 3.26 Access to the RailTel's facilities shall be allowed to the authorized persons of the CONTRACTOR only with the prior intimation to RailTel's Engineer.
- 3.27 All faults shall be intimated to the CONTRACTOR'S supervisor/ authorized person by either RailTel's Network Operation Centre (NOC) or the Engineer as indicated through telephonic communication, e-mail or through fax. For this the CONTRACTOR shall provide RailTel with the contact number, both landline and Mobile & e-mail address / Fax no. within 10 days from the award of the contract.
- 3.28 The locations of repeater/cable route are indicated on the as-built drawings to be supplied by RailTel after award of contract to a successful Tenderer. However, It is advisable that Tenderers must visit site to familiarize themselves with all constraints, restrictions, access requirements and available infrastructure. The CONTRACTOR shall not be eligible for any adjustment in cost and time, on account of any lack of data regarding above. The Contractor may visit the OFC route and satisfy himself before quoting the rate. However, the route details mentioned in Annexure-A are enclosed for reference only.
- 3.29 While executing the job at site by the CONTRACTOR, penalty claimed against any damage caused to the infrastructure of RailTel & other parties shall be borne by the Contractor.
- 3.30 Tenderers are advised to submit their quotations strictly based on the terms, conditions, and specifications in the tender document and not to stipulate any deviations.
- 3.31 Calibration of test and measuring instrument – instruments should always be calibrated, instruments like OTDR/splicing machine/power meter to be jointly tested & report signed once every month.
- 3.32 The CONTRACTOR becomes defaulter on the following conditions:
- 3.32.1 If he fails to repair fault and make the OFC link available within 12 hours.
- 3.32.2 Improper maintenance resulting in down time / consumables / loss of parts.
- 3.32.3 Loss or damage to RailTel's property due to the acts of Contractor.
- 3.32.4 In the event of RailTel receiving notice from any statutory authorities or from external agencies on account of loss/damage to their property due to the acts of Contractor.

- 3.32.5 During the contract period, if the CONTRACTOR has defaulted more than once or the defaulting case of the Contractor is severe, then RailTel has the right to terminate the contract and forfeit encash the Performance Guarantee Amount, if deemed necessary.
- 3.33 **ESCALATION:** The maintenance charges quoted by the CONTRACTOR shall be kept firm till the completion of entire period of contract, and no Price Escalation shall be payable on any ground. GST will be paid as per actual at the prevailing rates.
- 3.34 Contractor (successful tenderer) is accountable for timely payment to staff employed by him for the contract.
- 3.35 The contractor shall indemnify the Company against all losses or damages, if any, caused to it on account of acts of the personnel deployed by him. The contractor shall ensure regular and effective supervision and control of the personnel deployed by him and giving suitable directions for undertaking the contractual obligations.

**4. PAYMENT TERMS:**

**FOR “SOR -A” items:**

- 4.1 As per provisions of tender document, payment will be made by RailTel on certification of work by respective Engineer of the section. Submission of bills within 15 days for previously completed two months period is mandatory failing which a penalty as defined shall be charged. Bill of SOR-B and its status shall be sent along with next billing cycle of SOR-A.
- 4.2 Even though the maintenance charges are worked out on a monthly basis, the CONTRACTOR shall be paid once in two months for the maintenance charges for two months period subject to submission of bill along with defined documents.
- 4.2.1 6 identical billing cycles of 2 month period each will be considered during any financial year. The period should be viz. April to May, June to July, Aug to Sept, October to November, December to January & February to March.
- 4.2.2 If the date of LOA is not coinciding with the beginning (1st date of the month) of any period (i.e. 1<sup>st</sup> April/1<sup>st</sup> June/1<sup>st</sup> August etc), the first billing period from the date of issue of LOA will be taken till closure (last date of the month) of instant 2-month period. For example, if LOA is issued on 10<sup>th</sup> April, the first billing cycle shall be from 10<sup>th</sup> of April to 31<sup>st</sup> May allowed to be taken proportionately. Subsequently, the billing cycle will continue with the regular 2 Month billing period.
- 4.3 Cumulative Repair time is defined as the total time taken in each billing period of consecutive two months where the link is not available for service in the jurisdiction of the contractor. This does not include the time taken for planned

works. If the OFC has to be cut and spliced for a planned work the working fibers shall be made available within 2 hours beyond which the time shall be added to the Cumulative repair time, unless otherwise authorized by RailTel's Engineer. For the situation like flood, fire etc., beyond the control of contractor. Unforeseen circumstances to be decided at the discretion of RailTel, the extra time taken for repair may not be added in the cumulative repair time. The relaxation in 'extra time taken to repair the failure' will be considered as per the reports of the GPS Tracking Devices only.

- 4.4 The amount payable against the maintenance charges is dependent upon the Cumulative Repair Time taken by the Contractor for the restoration of all OFC link cut/faults occurred during each billing period of consecutive two months. Accordingly, the value of the maintenance charges per month shall be decided as per the following:
- 4.4.1 Cumulative Repair Time of the faults in each billing period of consecutive two months Up to 6/8 hours for backbone network, 8 hrs. for HDD Network (if failure occurs in HDD section) and 8 hrs. for city access overhead network (if failure occurs in overhead section) as applicable: 100 % payment of monthly maintenance charges. However, cost of JE over and above one set (2 nos) in two months (one JE per month) may be reimbursed along with cost of joint pit as per the SOR-B rates. Cost of JE or JE and Joint pit (Material only) has to be reimbursed beyond 2 nos in bi-monthly bill. In case of city access network, this will be applicable only to the section maintained by the contractor free of cost.
- 4.4.4.1 Deduction as defined shall be made from monthly maintenance charges if the Cumulative repair time of the faults in each billing period of consecutive two months exceeds by 2 hours or part thereof.
- 4.4.4.2 Further deduction as defined shall be made from monthly maintenance charges if the Cumulative repair time of the faults in each billing period of consecutive two months exceeds by next two hours or part thereof
- 4.4.4.3 The following documents must be submitted duly certified by the RailTel's Engineer along with the bill for payments for the respective sections: -
1. Month wise cumulative repair time taken.
  2. Any other Recovery for contractor's fault.
  3. Certificate showing the due Payments have been made to all Team Members by the Contractor as per the prevailing minimum wages act. The tenderer shall furnish an undertaking that he shall indemnify RailTel, being the principal employer, in the event any liability pertaining to employee of tenderer engaged in the current contract.

4. Hand corrected copy of relevant sheets of As Built Drawings with signature of Engineer. (Copy ABD available with Engineer shall also be corrected).
5. EPF, ESI & Wage Register documents of all the employees deployed in the section for last two months. There should be PF A/c & ESI registration No. with the contractor. All the statutory provisions have to be made by the contractor.

4.4.4.4 The Penalty imposed on account of various reasons / Slippages in accordance with the conditions stipulated in this document may go up to 50% of Bi-Monthly billed amount for the billing period. In case an agency is repeatedly touches the maximum level of penalty in consecutive billing periods, it will be treated as default and the contract may be terminated (The idea is to discharge the work in accordance with the contract efficiently rather than having major lapses and keep paying penalty repeatedly).

4.5 **Price Variation: Price Variation will not be allowed during the validity of contract.**

4.6 **No advance payments will be made.**

**FOR SOR B Item:**

4.6.1 100% payment will be paid after completion of work and on certification of RailTel engineer. Deduction of amount as penalty defined in case Non- execution of SOR-B within 3 months. The SOR-B bill has to be submitted within 3 months from the completion of the work.

4.6.2 Liquidated damages (LD) @ 0.5% per week subject to maximum of 20 % of the value of the work. Delay may be condoned on request of contractor, if the delay is beyond contractor's scope i.e. Railways/State Govt. Authorities permissions, Natural Calamities like flood etc. **20% of penalty will be charged for non completion of SOR B work.**

4.7 **Warranty period:** All material supplied / used and the work done by the contractor shall be guaranteed against the defective manufacture/workmanship for a period of 24 months. Cost of such defective material shall be recovered from subsequent bills or from 5% amount held (in case validity of contract is over).

4.8 **The contractor shall submit all bills/Invoices and any other claims (SOR-A, SOR-B, re-imburement etc.) against contract within 6 months from the end date of validity of the contract. After expiry of 6 months RailTel will not entertain any claim against the contract.**

**5. TECHNICAL SPECIFICATIONS**

## 5.1 INSTALLATION OF JOINT CLOSURE & SPLICING OF OFC

Only fusion splicing which is accomplished by applying localized heating (i.e. by electric arc or flame) at the interface between two butted, pre-aligned fibre ends, causing them to soften and fuse together, will be used on RailTel's network.

## 5.2 STRAIGHT JOINT FOR FIBRE OPTIC CABLE:

5.2.1 There are various types of joint enclosures available in the market. The procedure for assembly of joint enclosure is described in the installation manual supplied with straight joint enclosure. This includes the following:

- a) Material inside joint closure kit.
- b) Installation tools required.
- c) Detailed procedure for cable jointing.
- d) Procedure for re-opening the closure.

5.2.2. The Optic Fiber straight through joint closure (Mechanical seal type) to be used shall be of TVSE, Raychem model, FOSC, 3M make, ROXTEC, CommScope and shall be approved in advance by RailTel. The joint shall be protected CC/Fiber chamber (FRP) as approved by Engineer.

रेलटेल  
RAILTEL

RailTel Corporation of India Ltd.

(A Multinational Category - 1 Enterprise)

## **Chapter-6**

### **Upkeep of associated assets (Gears) like Power Plant, Air conditioners, Voltage stabilizers, Change over unit, D.G. Sets, Shelters, Earthing and Wi-Fi equipments**

#### **SCOPE OF WORK:**

1. At the time of taken over the section from outgoing maintenance agency, a station wise Joint inspection will be done by RailTel Engineer & Contractor representative to check the functioning of different equipments like Air Conditioners, DG sets, earthing, power plant and shelters and defects/faults are to be recorded jointly within 30 days from the date of start of maintenance and submit the report about the status of associated equipment within 30 days else it will be deemed that all the equipments installed are in working condition and responsibility for repairing will rest on contractor. One time cost of repairing/replacement of faulty/defective equipment will be borne by RailTel on actual basis.
2. Subsequently the contractor shall be responsible for proper & timely upkeep of the associated equipment
3. Payment at actual shall be made for parts/components replaced for proper upkeep of associated equipment.

#### **(A) Upkeep of Power plant equipment:**

The contractor will do proper up keep at least once in a month at each station which will consist, but not limited, of the following:

#### **Battery Charger:**

1. Testing of Auto changeover of SMRs.
2. Checking of current setting as per load.
3. Checking of input & output voltages and recording the same as per format given in the maintenance manual.
4. Checking of extension and reporting of alarms to NMS, wherever provided.
5. Checking of proper connection of input and load cables and distribution amendment provided.

**Battery Set:**

1. Checking and recording of individual cell voltages as per format given in the maintenance manual.
2. Checking of conductance of each cell with battery tester once in a quarter supervised by RailTel Engineer.
3. Cells whose voltages/conductance is found to be below prescribed value should be noted and Engineer advised.
4. Checking of battery voltages at equipment end.
5. Checking of proper connection of load cables.
6. Cleanliness of battery cells and bank.
7. Checking of sulphation/physical damage

**(B) Upkeep of Air Conditioners, Voltage stabilizers and Change over unit:**

1. Function checking, necessary adjustments, filter checking/cleaning, servicing etc. of AC, Voltage stabilizer, and change over unit at least once in three months' time (if required more frequently).
2. In case of malfunction of AC machine, voltage stabilizer and change over unit, corrective measures have to take to attend/rectify the failures within 48 hrs failing which penalty of Rs. 180/- (Excl. GST) per day will be levied.
3. Any Air Conditioner machine or its spare parts taken for repairing/ replacement should be returned within 3 days of carrying them outside the premises of RailTel and reinstalled by the AC mechanic.
4. The contractor will utilize services of trained A.C. mechanic for checking and attending the faults at site at his own cost.
5. Defective window type machine should be got repaired within 48 hours from nearest township in case minor defects. However, split type machine has to be maintained/ repaired by deployment of Air-Conditioner mechanic at site. The transportation cost for carrying the breakdown machine to and fro will be on contractor's account.
6. Over-hauling of the Room AC machines is to be done once every year during winter.
7. The full functioning of change over unit, wherever provided, should be checked once in a quarter.

8. A history register is to be maintained to keep record of repair/repairable spares, schedule breakdown details etc.
9. Payment, at actual, shall be made for all parts / components (including Gas filling) replaced.

**(C) Upkeep of Diesel Generator Sets:**

1. Function checking, necessary adjustments, servicing etc. of DG Set will be done once in one month time. This will consist of (but not limited to) the following:
2.
  - a. Testing on load.(1/2 Hour on load ,once in a month)
  - b. Testing of Auto start in case of AC failure.
  - c. Checking of Hour meter readings.
  - d. Checking of diesel oil/engine oil level/air filters.
  - e. Testing of Battery voltage of DG and its charging.
  - f. Cleanliness of the DG set.
  - g. Checking of frequency on loads.
  - h. Checking Voltage and Current on load.
  - i. Checking of DG earth resistance
  - j. water level in radiator (wherever applicable).

The contractor shall utilize services of trained / authorized D.G. mechanic for checking and attending the faults at site at his own cost.

3. All the consumables, Lubricants, Fuels and cleaning agents are to be provided by the contractor. Reimbursement for Lubricant & Diesel oil will be made as per actual, on production of bills plus 5% towards cartage charges to contractor.
4. The breakdown machine is to be attended and rectified within 72 hrs failing which penalty of Rs. 455/- per day (Excl. GST) will be levied. Quality of service to be performed should be entire satisfaction of RailTel engineer.
5. Any component of DG set taken for repairing/ replacement should be returned within 3 days of carrying them outside the premises of RailTel. The component after due repair should be reinstalled within 3 days from the date of taking the defective component. Removal, refitting of the same shall be done under supervision of train / authorized D.G. mechanic brought by the contractor. The contractor will also be responsible for carrying the defective component for servicing at workshop etc.
6. A history register is to be maintained to keep record of repair/repairable spares, schedule breakdown details etc.

**(D) Upkeep of Shelters/Building:**

The contractor will do the proper upkeep of shelter once in three months which will consists (but not limited to) of the following:

1. Checking of leakage of water and repairing of the same.
2. Tightening the nut & bolt of the shelters in case of loose.
3. Minor repair of shelter if any.
4. Checking of condition of doors, windows and locking arrangements
5. General cleanliness of shelter once in a month.

**(E) Upkeep of Earthing Arrangement**

The contractor will do the following activities as per schedule given below:

1. Watering of the earth pits on every visit (at least once in a month).
2. Checking of the physical connections at equipment ends.
3. Tightening of nut/bolts once in a quarter.
4. Measurement of earth resistance once in six months under supervision of RailTel Engineer. At least one measurement shall be done during peak summer.

**(F) Upkeep of Wi-Fi System & Equipments**

The contractor will do the following activities as per schedule given below:

1. Visual Inspection of all the system/equipments/wiring: Once in a month.
2. Confirming the reachability of all routers and switches: Daily.
3. Replacement of faulty equipment with coordination of NOC:As& when required.
4. Testing of Access point signal through mobile: Once in a month.
5. Testing of Backup of all the UPS (One UPS at a time): Once in a month.
6. Visiting station area for any ongoing work to take preventive maintenance with coordination of RLY: Once in a week.
7. Maintaining a history register for repair/maintenance/schedule testing etc.

**Chapter- 7****Annexure-C****Jurisdiction of OFC Maintenance Sections & Financial Bid Formats**

- a) The OFC section shall have at least one maintenance team stationed at the team headquarters. List of maintenance sections where the maintenance teams are to be deployed is furnished below.

Sl. No.	Sectional HQ	Section Details	Length of Sec. (RK M)	Bimonthly allowed cumulative repair time in hrs.	Type of OFC	GeM Bid Number
1	Bhagalpur	Kiul- Jamalpur	45.00	8 Hrs. each for U/G, O/H & HDD, if failure occurs		GEM/2026/B/7389020, Dt. 25.03.2026
		Jamalpur- Bhagalpur	53.00			
		Bhagalpur- Pirpaiti	50.00			
		Bhagalpur - Barahat	41.00			
		Jamalpur-Munger	7.00			

**Note:** City Access network will also be maintained by the maintenance team which will be up to around 15 % of total section length.

RailTel also reserves the right to add or delete any maintenance section. However, payment will be made as covered in the preamble.

- b) The list of window/split type room air conditioning machines and their section wise location as tabulated hereunder is indicative only. In future all the newly installed Air Conditioners will automatically be added in the maintenance section after completion of warrantee period. The same will be maintained by the maintenance team and the reimbursement will be done as per actual expenditure.

GeM Bid No. : GEM/2026/B/7389020, Dt. 25.03.2026									
Sl. No.	Team HQ	Station	Make	Model	Capacity	AC type	Date of Installation	Stabiliser (5KV A)	Auto sequencer
1	Bhagalpur	JMP EXCHANGE (2 NOS.)	LLOYD	GLS2415 6WBEL	2	SPLIT	02.09.22	NO	YES
2		BGP (02 NOS)	LLOYD	GLS2415 6WBEL	2	SPLIT	29.08.22	NO	YES
3		PPT (2 NOS.)	LLOYD	GLS2415 6WBEL	2	SPLIT	21.09.22	NO	YES

- C) The list of 5/7.5/15 KVA, Single / three Phases, Air Cooled, Diesel Generator (Silent type) and section wise location as tabulated hereunder is indicative only. In future all the newly installed Diesel Generators will automatically be added in the maintenance section

after completion of warranty period. The same will be maintained by the maintenance team and the reimbursement will be done as per actual expenditure.

<b>GeM Bid No. : GEM/2026/B/7389020, Dt. 25.03.2026</b>							
<b>Sl. No.</b>	<b>Team HQ</b>	<b>Station</b>	<b>DG Set Installed</b>	<b>Make</b>	<b>Model</b>	<b>Capacity</b>	<b>Date of Installation</b>
1	Bhagalpur	NIL	NIL	NIL	NIL	NIL	NIL



रेलटेल  
RAILTEL

RailTel Corporation of India Ltd.

(A Ministry Category - I Enterprise)



## RailTel Corporation of India Ltd.

### Eastern Region

19th Floor, Aurora Waterfront Building,  
Plot No. 34/1, Block -GN, Sector - V,  
Salt Lake City, Bidhannagar, Kolkata -700091, West Bengal

### Financial Bid Format

GeM Bid No.: - GEM/2026/B/7389020, Dt. 25.03.2026

**Name Of Work:** - Deployment of maintenance team for maintenance of optic fibre cable network and upkeep of associated gears like AC, DG, Stabilizer, Change over unit, Shelter and Wi-Fi Equipments in **Bhagalpur** section of RCIL/ER for a period of 2 years and extendable by one year on same terms and conditions

#### SCHEDULE OF REQUIREMENT (SOR)/ PRICE BID

Consignee(s)	Number of Clusters	Maintenance Charges per KM for 2 Years (INR) Incl. GST	Approximate kms for maintenance of optical fibre during contract period (2 Years)	Total Price (INR) Incl. GST
a	b	C	D	e = c x d
Con 1	1	To be quoted in GeM portal only	196.00	

RailTel Corporation of India Ltd.

(A Ministry Category - 1 Enterprise)

## Chapter-8

### Annexure-D

#### **Minimum Man & Machine/Equipments required to be engaged under one Maintenance Team:**

**(a) Manpower:**

1. Experienced Supervisor: (Preferably Diploma Holder in Electronics, Electrical or Graduate with relevant Experience in field work,) additional experience in the field of AC machine, DG sets will be desirable
2. Technician for Splicing & Measurements (main splicer).
3. Deleted.
4. Patrollers with cell phone for surveillance, liaison and foot patrolling and train patrolling (one Man for about 50-60 kms beat). However the contractor has to deploy extra manpower for as and when needed during any Railway work or other agencies work in the section.

**Note:- All patrollers should be mandatorily equipped with a GPS-based attendance application. The application shall be used during all day-to-day operational activities for attendance recording and continuous location tracking. Monthly real-time, app-based monitoring(attendance) data shall be made available and submitted during the processing of the monthly bill**

5. Bike patrollers for surveillance in city access cable area for 50-60 Kms.
6. Two Un-skilled manpower for trenching etc.
7. Driver of the vehicle.
8. One Diploma Engineer (ECE/CSE/IT) person for up keeping of Wi-Fi system provided at various stations in the section.

**(b) Vital Machines/ Equipments:**

1. Innova/ Qualis/Scorpio or equivalent Utility Vehicle for transportation of men, machines and stores. Vehicle shall be in good working condition & should not be more than three years old.
2. Portable Generator set Kirloskar/Honda/Eicher or similar make, lighting arrangement like emergency light/gas light.
3. Fusion Splicing Machine with 2 cleavers, Fujikura/Fitel/INNO Korea or similar make.
4. Power Source and Power Meter, JDSU/Anritsu/Yokagawa or similar make.
5. OTDR (Minimum range - 200 Kms), Anritsu/JDSU/Yokagawa or similar make.

6. OFC cable Route Detector
7. Spare battery with charger for splicing machine.
8. Cable Splitter for vertical cutting of PVC sheath & armour
9. All sorts of patch-cords and connectors for the purpose of measurement
10. Duct Cutter
11. Road-o-meter.
12. Clamp type earth megger and clamp type AC/DC multimeter
13. Communication Gadget: As required (Telephone, Cell phone, E-Mail etc.)
14. Tool/Tackles kit.
15. Blow lamp/ hot air gun for sealing joint closure.
16. 1 Km. length dummy fiber spool.
17. 500 Mtr. Aerial OFC having 24 fibers.
18. Minimum 50 Mtr. Duct with couplers
19. Rexene/Polythene & Umbrella cover etc.
20. Portable vacuum cleaner, Eureka Forbes/Bosch/Phillips or similar make.
21. Aluminum Ladder for maintenance of Wi-Fi Equipments.
22. GPS Tracking Devices for Team Vehicle & Patrollers for live tracking of Team. The relaxation in 'extra time taken to repair the failure' will be considered as per the reports of the GPS Tracking Devices only.
23. Laptop PC with minimum Core-i3 or equivalent processor, 4 GB RAM, with Windows Operating System and with Wireless for fault rectification of Wi-Fi Network of Railway Stations.

**Note: OFC test and measuring instruments must have been calibrated in a year once from an established national Testing Organization/ lab. Upto date Certificates should always be available.**

Manpower and equipments should be available with the maintenance teams round the clock as listed above. However, contractor can add more manpower & equipments for speedy maintenance & minimizing downtime without any extra cost implications to RailTel.

In case the main Splicer of the team is on leave, standby Splicer must be arranged in advance by the contractor In case of absence of supervisor/ technician/splicer/patrolmen from site except sanctioned leave granted in consultation with RailTel engineer (indicated in item (a) 1 to 8 in list given above), penalty as defined will be deducted.

No man power or equipment can be changed without prior ascertaining the suitability by the Engineer & his approval. Each such change shall be pre-reported in writing to Engineer.



रेलटेल  
RAILTEL

RailTel Corporation of India Ltd.

(A Multinational Category - 1 Enterprise)

## Chapter-9

### Annexure-E (अनुलग्नक-ए)

**Penalty to be imposed for the non-compliance/deficiency in the maintenance of OFC, AC, DG and Wi-Fi system covered under this maintenance contract:**

S No.	Description of deficiencies	Penalty Rate (Excl. GST) Rs.
1	Non-submission / non-modification of as built drawing (Only modifications made to be submitted)	Rs. 910/- per fault
2	Non-submission of OTDR traces to be taken before and after rectification of cable fault /cut (involving two joints).If OTDR traces is submitted within next billing cycle, the penalty will be returned back to the contractor.	Rs. 4540/- per section
3	For provision of joint pit within 30 days, no penalty. From 31 day to 60 days, penalty of Rs. 4540/- per joint pit and from 61 days to 90 days penalty of Rs. 9080/- per joint pit. <b>After 90 days, case will be considered for termination.</b>	
4	Swapped fibers not restored (involving at least one joint)	Rs. 4540/-
5	Cable laid during fault restoration / rectification (small length) at lesser depth without protection.	Accepted rate of respective SOR – B + 20 %)
6	Cable laid temporarily over bridges and leads to subsequent failure (involving two joint).	Rs 2 x (accepted rate of respective SOR – B + 20 %)
7	Splice loss of all fibers not within prescribed limit (0.05 db per splice)	Rs. 5450/-
8	In case MTTR exceeds the prescribed restoration time for the section 6/8 Hrs Bi-monthly for backbone network and 8 Hrs for access network)	Rs. 4540/- per two hours or part thereof.
9	Unavailability of communication with maintenance team/patroller	Rs. 910/- per day
10	Non-Submission of OTDR reading and Power meter readings of all fibers (Once in a four month).	Rs. 4540/- per section+ Rs. 2270/- for every week or part thereof till the next periodical report falls due
11	Failure or non availability of Transport/Vehicle.	Actual cost of hiring alternative vehicle+ Rs. 910/- each trip from monthly bill.(Per day)
12	Non-Submission of joint report indicating the fault to be attended within 90 days from Date of deployment of team	Rs. 2270/- per week or part therefore beyond 90 days up to next 45 Days from the date of deployment of the team.

13	Non-Submission of bill for previously completed two months within 15 days of completion of billing period.	Rs. 180/- per week beyond 10 days up to next billing cycle, subsequently Rs. 455/- per week.
14	Absence of Supervisor/ Technician/Splicer/ Helper/ Patrolmen etc. from site.(indicated in item (a) 1 to 7 of Annexure-D).	Rs. 355/- per day each for patroller, Technician, Helper and assistant splicer and Rs. 910/- per day each for supervisor & Splicer (If the person is under sanctioned leave then it should be in knowledge of Engineer and contractor should deploy another person in place of absent person).
15	Non availability of Vital equipments (Except vehicle)	Rs. 455/- per day
16	If foot /bi-cycle patrolling not done	Rs. 545/- for one time-per block/sub section in a month(i.e. if foot patrolling not done in a month for one sub/block section penalty per month imposed will be 3x545 = Rs. 1635/- per month since three times in a month to be done)
17	Non-execution of SOR–B work within 3 months	20% of the cost of SOR-B work from SOR-A bill of that period (work communicated in writing by authorized representative of RailTel)
<b>AIRCONDITIONER MAINTENANCE</b>		
18	Breakdown duration exceeding 48 hrs.	Rs 180/- per day
19	Non- Maintenance of Faulty AC within 03 months (in case of faulty before joining of team)	Rs. 180/- per day
<b>DG SET MAINTENANCE</b>		
20	Breakdown duration exceeding 72 hrs.	Rs 455/- per day
21	Non- Maintenance of Faulty DG within 03 months (in case of faulty before joining of team)	Rs. 455/- per day
22	Upkeep of shelter/earthing arrangement /power plant etc.	Rs. 215/- per day per location.
23	Joint Marker	Penalty Rs. 910/- per joint marker for non-provisioning of Joint marker within 30 days
24	Criss crossing of fibers during carrying out the SOR A works.	Rs. 1820/- per joint
25	Absence of Diploma Engineer (ECE/CSE/IT) for up keeping of Wi-Fi system	Rs. 910/- per day
26	Deleted	
27	Penalty (Per Day) for Wi-Fi System/ Equipments not attended within 24 Hrs.	Rs. 1700/- per day

28	Penalty for excess time in restoration of failure in case of 0/10/20 dB/ Patch cord faulty (exceeding 02 hours)	Rs. 4540/- per two hours or part thereof.
29	Non-providing of uniform (2 sets) and Florescent green Safety Jackets (2 sets) (with RailTel logo in both front and back) within 30 days of joining of team	Rs. 200 per person per day after 30 days of joining of maintenance team



रेलटेल  
RAILTEL

RailTel Corporation of India Ltd.

(A Ministry Category - I Enterprise)

**Chapter-10****Annexure-F (अनुलग्नक-F)****Schedule of Rates –B (SOR-B)****For OFC Route strengthening & Diversion works:**

SN	Item	Description	Unit	Unit Rate (Rs.) Excl. GST
1	FRP / RCC Chambers	<b>Supply &amp; installation of joining pit as per drawing with cover and required trenching to ease out cable/duct</b>		
1 A	RCC Chambers	Supply, transportation and installation of RCC joint chamber with two piece top cover and bottom cover with holes for drainage and cable entry, as per drawing no. RCIL/ER/DRG-02/06. (Reinforcement drawing enclosed). This includes trenching for jointing pt, backfilling and ramming of the pit after placing the joint closure and cable loop in the chamber without causing any damage to the same and consolidation of soil as well as disposal of excess soil.	No.	4456/-
1 B	FRP Chambers	Supply, transportation and installation of FRP joint chamber with top cover and bottom cover with holes for drainage and cable entry, as per drawing no. 2002/PFB/0487. This includes trenching for jointing pit, backfilling and ramming of the pit after placing the joint closure and cable loop in the chamber without causing any damage to the same and consolidation of soil as well as disposal of excess soil.	No.	5968/-
1 C	Top plate of joint pit	Supply, Transportation and fixing of top plates. Whether the top plates are missing or damaged. The top plate should be as per drawings no. RCIL/ER/DRG-02/06.	No.	844/-
1D	RCC Chambers	Cost of RCC Chamber (including 400 mm height sand) for reimbursement against the additional joint chambers used during bi-monthly billing period for OFC cut due to NHAI/RLY (Over & above 02 numbers)	No.	4080/-
2	FRP/RCC Route Marker	<b>Supply and fixing of cable route markers as per drawing</b>		

2 A	RCC Route Marker	Supply, Transportation and fixing of RCC cable route markers as per drawing no. RCIL/ER/DRG-01/06. Markers shall normally be provided at a distance of every 100 mtrs on the cable route, at places/comers where the route of the cable changes, on either side of culverts, bridges, L.C. Gates, road cutting etc. These shall be engraved with letters "RCIL OFC" and suitably painted. The markers shall be painted with Green when placed near joint chambers and should be painted with orange at all other places. The engraved portion "RCIL OFC" should be painted with white.	No.	287/-
2B	FRP Route Marker	Supply, Transportation and fixing of FRP cable route markers as per drawing no. RCIL/ER/DRG-01/06. Markers shall normally be provided at a distance of every 100 mtrs on the cable route, at places/comers where the route of the cable changes, on either side of culverts, bridges, L.C. Gates, road cutting etc. These shall be engraved with letters "RCIL OFC" and suitably painted. The markers shall be painted with Green when placed near joint chambers and should be painted with orange at all other places. The engraved portion "RCIL OFC" should be painted with white.	No.	301/-
3A	Concreting	Concreting for protection of OFC cable		
		<p>Concreting to be provided: In rocky areas where trench is of low depth and OFC is to be protected.</p> <ol style="list-style-type: none"> <li>1) At bridges / culverts to protect OFC on approaches.</li> <li>2) Wherever necessary, as directed by RCIL Engr.</li> </ol> <p>The proportion of cement, metal and sand is 1:3-6 (1-cement, 3-stone 3/8", 6-sand) with curing and ensuring proper setting. Thickness should be 0.15 mtrs. and width is 0.3 mtrs. in situations 1 &amp; 2 above.</p>	Cu. m	9378/-
4A	G.I. (Pipe on RCC Bridges)	Supply & laying of 50 mm dia GI Pipe IS1239 medium grade with holes drilled as an anti-theft measure coupling etc. on bridges/trenches/other surfaces with CC at	Mtr.	576/-

		every 1m as per drawing. Concreting rates shall be separate as per item 3A.		
5A	Trenching (1Mtr with bricks)	Trenching to a depth of 1 mtr and appropriate width for pipe/duct/Cable and backfilling after laying OFC/duct. This includes provision of 9 bricks /mtr & Fixing of route marker of RCC/FRP embossed "RailTel" and painted with Orange, as per specification.	Mtr.	221/-
5B		<b>Trenching to a depth of 1.2 mtr and appropriate width for pipe/duct/cable and backfilling after laying OFC as per specification.</b>	Mtr.	
5 B (1)	<b>Trenching (1.2Mtr depth)</b>	Trenching in normal soil to a depth of 1.2 metre and 300 mm wide and backfilling after laying of OFC / pipe /duct as per specification.	Mtr.	92/-
5 B (2)		Trenching in hard soil to a depth of 1.2 metre and 300 mm wide and backfilling after laying of OFC / pipe / duct as per specification.	Mtr.	128/-
5C	<b>Hard Rock</b>	<b>Cutting hard rock for 0.3 mtr depth of trench</b>		
		Cutting hard rock of the following thickness of strata 0.3 m depth (0.3 m width) and concreting thereafter as per direction of site In charge (cost of concreting will be as per SOR item No. 3 A)	Mtr.	322/-
6	Sand filling	Providing dry sand in FRP/RCC joint chambers up to 400mm height	No.	891/-
7A	Laying of OFC	Laying of OFC/ QUAD Cable in trench and through HDPE/GI/RCC pipes where ever necessary.	Mtr.	15/-
7B	Laying of HDPE duct	Laying of HDPE duct in trenches. Supply and pulling of nylon rope through it.	Mtr.	15/-
8	<b>OFC Joint Enclosure</b>	Supply & Provision of OFC Joint closure including Splicing (24/48Fibre). The joint Enclosures shall be TVSE, Raychem model FOSC, ROXTEC, 3-M, CommScope, VXL, R&M Make	No.	10503/-
8 A		Rectification & re-splicing of existing mid section OFC joints. This includes supply and provision of joint repair kit & sleeves	No.	7335/-

8B		Cost of Joint closure (TVSE, Raychem model FOSC, ROXTEC, 3-M, CommScope , VXL,R&M Make) for reimbursement against the additional joint closures used during bi-monthly billing period for OFC cut due to NHAI/RLY (Over & above 02 numbers)	No.	2905/-
9	<b>Repair of Terminal OFC Joint.</b>	<b>Repair of existing OFC Terminal Joint (24/48Fibre). This includes Splicing of all the 24/48Fibres./dropping of fibre/pigtail as required.</b>	No.	
9 A		Repair of existing OFC Terminal Joint (24/48Fibre)	No.	4414/-
9 B		Splicing / dropping of each fibre / pigtail from the terminal joint mentioned above.	No.	122/-
10	<b>Horizontal Drilling</b>	<b>Horizontal Drilling at a approximately depth of 1.65/1.2 m below the formation level of the earth including insertion of DWC pipes along with couplings etc.</b>		
10 A		In case of small stretches (less than 100 m)	Mtr.	911/-
10 B		In case of long stretches (more than 100 m)	Mtr.	610/-
11	DWC Pipe	Supply of DWC pipe 78/63 mm OD/ID as per IS 14930 Part II in 30 mtrs length with 2 snap fit couplers for jointing Each 30 mt coil length.	Mtr.	268/-
12	Vehicle for Adjoining section	Additional transport charges for attending failures in adjoining section in emergency	Km.	15/-
13	Rectification of high loss/break of fiber in existing joint enclosure.	Excavation of trench or opening /finding the existing joint pit approx. 100 mtr as a preparation for testing/rectification of fiber and its reinstatement by backfilling sand and ramming of excavated soil etc. This includes the rectification of high loss/ break of fiber	No.	7362/-
14	<b>Transportation of Cable / HDPE Duct</b>	<b>Transportation of OFC cable/HDPE duct drum</b>		
14 A		Transportation of OFC cable (drum – 3 km) / HDPE Duct (coil – 1 km) from RailTel's stores other the nominated stores (To and Fro differential distance form nominated stores will be considered).	Drum Km	20/-
15	<b>Pulling of aerial fiber</b>	<b>Pulling of aerial OFC with 4 mm G.I. wire support clamped at every 1 Mtrs approx..</b>	RM	
15 A		Drawl of unarmoured overhead OFC (6/8/12/24fibre) with sufficient ground clearance (to avoid interruption of cable by over consignment truck) with suitable binding arrangement (messenger). This included supply of 6/8/12/24fibreover head	Mtr.	54/-

		cable and other consumable required to draw the cable		
15 B		Supply and provisioning of overhead OFC mid section / terminal joint (6/8/12/24Fibre) including splicing of all the fibers	No.	3651/-
16	Cable route tracing	OFC route tracing & submission of corrected cable route plan (soft copy in CD and two hard copies). Cable Route plan should contain LC gates, culverts/bridges, joint chambers, stations, offset, depth of cable at every 100 mtrs	Km.	871/-
17	Track/Road/Platform crossing	Trenching to a depth of 1mtr below rail/Road/Platform level, placing of G.I. Pipe (as per IS 1239 pt. I & pt.I I), 50 mm dia.(inside) in the trench made, backfilling and ramming	Mtr.	663/-
18	<b>Protection work at bridge/culvert</b>	<b>Supply and provision of Channels, clamps, fixtures, Troughs, nuts and bolts etc.</b>		
	Protection work at bridge / Culvert	Supply & Fixing of M.S. Channel, (C-section, 100 mm x 50 mm x 6 mm) as per drawing No. RCIL/ER/DRG-08 A & B/06		
18 A		Channel (bracket) length – 1.5 metre	No.	1166/-
18 B		Channel (bracket) length – 1.2 metre	No.	931/-
18 C		Channel (bracket) length – 0.9 metre	No.	703/-
		Supply & Fixing of bracket made of M.S. flat (75 mm x 12 mm) as per drawing No. RCIL/ER/DRG-08 A & B/06		
18 D		Bracket length – 1.5 metre	No.	931/-
18 E		Bracket length – 1.2 metre	No.	744/-
18 F		Bracket length – 0.9 metre	No.	556/-
18 G			Supply & Fixing of “Z” clamp, of M.S. flat (300 mm x 38 mm x 12 mm) including supply and provision of Hexagonal Nuts & Bolts 10 mm x 38 mm with spring washer, flat washer, check nut for fixing of M.S. Channel on girder bridges as per drawing No. RCIL/ER/DRG-08 A & B/06.	No.
18 H	Protection work at bridge / Culvert	Supply & Fixing of (perforated) G. I. Pipe (as per IS 1239 Pt. I & Pt. II) 50 mm dia (inside) for entry of cables on bridges / culverts as per drawing No. RCIL/ER/DRG-08 A & B/06. Perforation of pipes to be done as per drawing No. RCIL/ER/DRG/11/07.	Mtr.	576/-
18 I		Supply & Fixing of Clamp, made of M.S. flat (350 mm x 38 mm x 6 mm) including supply and provision of Hexagonal Nuts & Bolts 8 mm x 38 mm with spring washer, flat washer, check nut for fixing of G.I. Pipe (50	No.	87/-

		mm dia) and for binding trough & trough cover o M.S. Channel as per drawing No. RCIL/ER/DRG/11/07.		
18 J		Supply & Fixing of G.I. Trough, (C-section, 75 mm x 50 mm x 50 mm) 1.2 mm thick on M.S. Channel or as per requirement depending on site condition as per drawing No. RCIL/ER/DRG/10/06.	Mtr.	241/-
18 K		Supply & Fixing of G.I. Trough cover, (C-section, 78 mm x 25 mm) 1.2 mm thick on M.S. Channel or as per requirement depending on site condition as per drawing No. RCIL/ER/DRG/10/06.	Mtr.	174/-
18 L		Supply and provision of split G.I. Pipe 75 mm x 300 mm with clamps 250 mm x 38 mm x 6 mm and Hexagonal Nuts & Bolts 10 mm x 38 mm with spring washer, flat washer, check nut for fixing the Clamps (as replacement of G.I. Pipe coupler)	No.	543/-
19	Rectification of criss crossing of fibers in a joint enclosure	Rectification of criss-cross of fibers in a joint enclosure (rate per joint)	No.	7335/-
20	Petrol man	Rate of petrol man per day	No.	496/-
21	Splicing	Splicing and termination of 48 Fiber OFC ( Splice enclosure supplied by RailTel)	No.	4863/-
22	Dropping	Rate for dropping/splice of through fiber for each dropping/splicing	No.	122/-
23	Aerial fiber	Splicing rate for 6/12/24 aerial fiber	No.	122/-
24	Drawing of Armored 12/24F OFC	Drawing of Armored 12/24F OFC on the poles using suitable fixtures (as per the type of poles). After completion of drawing of OFC, all the 12/24 fibers should be tested. If any break/high loss even observed, the same shall be rectified by the agency without extra cost	Mtr.	54/-
25	Releasing of O/H cable	Releasing of O/H cable from electrical poles and depositing of material in store.	Mtr.	12/-
26	Pulling of OFC	Pulling of OFC through already laid HDPE duct /GI pipe /DWC pipe	Mtr.	12/-
27	Painting of outdoor assets	All outdoor assets like prefab /building, channels and other protection equipment on steel girder bridges etc to be painted as per IR telecom manual.	Sq. Mtr.	74/-

28	Laying through Floor/Payment/Wall	<p><b>Laying of cable as below, after cutting floor/pavement/wall and making holes incl. embedding the cable at an average depth as below and mending good the damages to original finish incl. removing the rubbish.</b></p> <p>(29 A) From 2.5 sq mm to 35 sq mm at an average depth of 75 mm in floor/pavement/wall etc.</p> <p>(29 B) Above 35 sq mm to 95 sq mm at an average depth of 100 mm in floor/pavement/wall etc.</p> <p>(29 C) Above 95 sq mm at an average depth of 100 mm in floor/pavement/wall etc.</p>	Mtr.	154/- 194/- 221/-
29	Laying and clamping of OFC/electrical cable inside prefab/Building/Equipment room	Laying and clamping of OFC inside prefab/Building/equipment room including supply and fixing of PVC conduit and U/D clamps	Mtr.	122/-
30	Supply and installation of 15/22/30 Amp (MCB) Board	Supply and fixing 5 amps to 32 amps rating, 240/415 volts, "C" curve, miniature circuit breaker suitable for inductive load of following poles in the existing MCB DB complete with connections, testing and commissioning etc. as required (Single pole and neutral)	No.	536/-
31	Cleaning of OFC room/Hut	Cleaning / clearing of water-logged area, bushes near the ambience of OFC/equipment room	Per person per day	496/-
32	Clamping of HDPE duct and OFC cable	Clamping of HDPE duct and 6 Quad cable on the wall at 1 m interval separately including supply of steel clamps, saddles, cement and other materials as required for holding the table and duct properly.	Mtr.	122/-
33	Treatment of roof leakage	Providing and laying water proofing treatment on roofs of slabs by applying cement slurry mixed with water proofing cement compound consisting of applying: a) after surface preparation, first layer of slurry of cement @ 0.488 kg/sqm mixed with water proofing cement compound @ 0.253 kg/sqm, b) laying second layer of Fibre glass cloth when the first layer is still green. Overlaps of joints of fibre cloth should not be less than	Per sq. mtr	435/-

		<p>10 cm. c) third layer of 1.5 mm thickness consisting of slurry of cement @ 1.289 kg/sqm mixed with water proofing cement compound @ 0.670 kg/sqm and coarse sand @ 1.289 kg/sqm. This will be allowed to air cure for 4 hours followed by water curing for 48 hours. The entire treatment will be taken upto 30 cm on parapet wall and tucked into groove in parapet all around. d) fourth and final layer of brick tiling with cement mortar (which will be paid for separately). For the purpose of measurement, the entire treated surface will be measured.</p>		
--	--	--	--	--

\* Additional new work

Signature of the Tenderer with Stamp

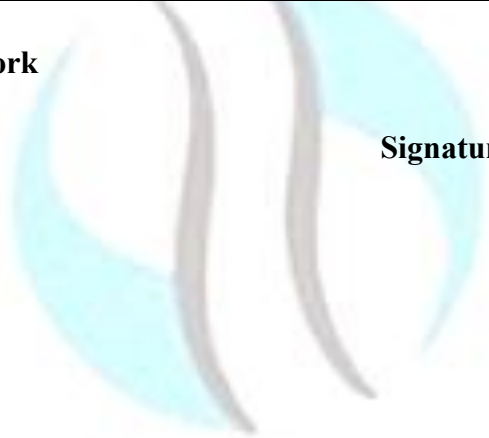

रेलटेल  
RAILTEL

RailTel Corporation of India Ltd.

(A Ministry Category - I Enterprise)

## Chapter-11

### Details of Nominated stores

Sec. No.	Maintenance Section HQ	Primary Store	Secondary Store
1	Bhagalpur	New Jalpaiguri	Katihar



रेलटेल  
RAILTEL

RailTel Corporation of India Ltd.

(A Ministry Category - 1 Enterprise)

## **SECTION-II**

### **Chapter-12**

#### **INSTRUCTIONS TO TENDERERS AND GENERAL CONDITIONS OF CONTRACT (GCC)**

##### **INDEX**

<b>PARA</b>	<b>SUBJECT</b>
1.	GENERAL INSTRUCTIONS
2.	INTERPRETATIONS
3.	LOCAL CONDITIONS
4.	COMPLIANCE TO TENDER CONDITIONS, SPECIFICATIONS &DRAWINGS
5.	SUBMISSION OF EARNEST MONEY DEPOSIT
6.	SUBMISSION OF OFFERS
7.	UNIT PRICES
8.	VALIDITY OF OFFER
9.	RATES DURING NEGOTIATION
10.	OPENING OF TENDER
11.	NON-TRANSFERABILITY AND NON-REFUNDABILITY
12.	ERRORS, OMISSIONS & DISCREPANCIES
13.	WRONG INFORMATION BY TENDERER
14.	QUALIFYING CRITERIA
15.	SYSTEM PERFORMANCE GUARANTEE
16.	EVALUATION OF OFFER
17.	AGREEMENT
18.	TENDERER'S ADDRESS
19.	SETTLEMENT OF DISPUTES/ ARBITRATION

**INSTRUCTIONS TO TENDERERS AND CONDITIONS OF TENDERING**

**1. GENERAL INSTRUCTIONS**

- 1.1 Tender is invited by the Executive Director/Eastern Region on behalf of M/s RailTel Corporation of India Limited, Kolkata for the work as defined in preamble para 1.
- 1.2 The Preamble, Instructions to Tenderers and Conditions of Tendering, Scope of work, Description of work & SORs, all Annexure & Forms and Corrigendum & Addendum etc., if any, shall here after, be collectively referred to as the "Tender Document".

**2. INTERPRETATIONS**

The following terms wherever occurring in the tender Document and wherever used throughout the execution of the contracts, shall, unless excluded by or repugnant to the context, have the meaning at tribute there to as follows:

"**CONTRACT**" Means the Contract resulting from the acceptance by the Executive Director of this Tender whether in whole or in part.

"**CONTRACTOR**" Means the successful Tenderer, i.e. the Tenderer whose Tender has been accepted either in whole or in part.

"**CONTRACTOR's REPRESENTATIVE**" Shall mean a person in supervisory capacity who shall be so declared by the Contractor and who shall be authorized for any work specified in the Contracts. He shall be responsible for proper execution of contracts.

"**MONTH**" Means any consecutive period of thirty days.

"**MATERIALS**" Means all equipments, tools, special aids, plants and testing equipments and appliances for execution of contract.

"**PoP**" Means point of presence i.e. a place or premises where any telecom equipment is placed.

"**RailTel**" Means M/s RailTel Corporation of India Limited, Office of the Executive Director, Eastern Region, 19<sup>th</sup> floor, Aurora waterfront, GN 34/1, Block- GN, Sector –V, Salt Lake, Bidhannagar, Kolkata-700091, West Bengal (complete address of the Executive Director to be furnished)

"**Section**" Means the areas to be taken up by the Contractor for execution of maintenance work and other maintenance related work given in the tender document.

**ENGINEER** shall mean a RailTel employee who is responsible for maintenance

carried out in particular section by maintenance team.

**ENGINEER-IN-CHARGE (EIC)** shall mean a Senior Manager of RailTel, responsible for ensuring that all field works covered by the contract are carried out in accordance with approved designs, drawings & specifications and conditions of contract as agreed to.

**“BLOCK SECTION”** Means the distance along the railway track between two consecutive Railway stations.

**"TENDERER"** Means and includes any firm of engineers or Contractors or any company or body, corporate or otherwise, who submit the Tender which has been invited.

**"WORK OR WORKS"** Means all or any of the items of the work for which the Tenderer /Contractor has Tendered/contracted according to the specifications, drawings and Annexure here to annexed or to be implied there from, or incidental there to or to be here after specified or required in such explanatory instructions and drawings, being in conformity with the specifications, drawings, Annexure and schedules and also such instructions and drawings additional to the afore mentioned as may from time to time be issued by the Engineer during the progress of the contracted work.

**"WRITING"** Includes all matters written, typewritten or printed either in whole or in part.

### 3. LOCALCONDITIONS

- 3.1 It will be imperative on each tenderer to fully acquaint himself with all the local conditions and factors which would have any effect on the performance of the contract before quoting. The Executive Director shall not entertain any request for clarifications from the tenderer regarding such local conditions. No request for the change of price, or time schedule of delivery of stores shall be entertained after the offer is accepted by the Executive Director on account of any local condition or factor.
- 3.2 The intending tenderer is advised to study the tender document carefully before quoting. Any submission of a bid by the tenderer shall be deemed to have been done after a careful study and examination of these documents with full understanding of the implication there of. These conditions and specifications shall be deemed to have been accepted unless otherwise, specifically commented upon by the Tenderer in his quotation. Failure to adhere to anyone or all these instructions may render his offer liable to be ignored without any reference.
- 3.3 Should a tenderer find discrepancies in, or omission from the drawings or any of the Tender document or he has any doubt to their meaning, he should at once

notify the RailTel who may send a written clarification to all tenderers.

**4. COMPLIANCE TO TENDER CONDITIONS, SPECIFICATIONS & DRAWINGS**

- 4.1 The tenderer shall indicate paragraph by paragraph for each section of the tender document that either his tender complies in every respect with the requirements of each clause and sub clause or if not, precisely how they differ from the requirements of the tender. In later case the Tenderer shall enclose a separate statement indicating only the deviations for any clause or sub-clause of Conditions of Contract, Instructions to Tenderers and Conditions of Tendering, Technical Specifications, Preamble etc. which he proposes with justifications for deviations proposed. The Executive Director reserves the right to accept or reject these deviations and his decision there on shall be final.
- 4.2 The Services offered shall be in accordance with the drawings and specifications & conditions of the contract.
- 4.3 Contractor should give details of contract carried out giving details of the name of the contract, date of award, length of the section, value of the contract, the original execution period and the actual execution time taken. This will be supported by a user certificate.
- 4.4 The tenderer should provide information about the compliance of various clauses /sub clauses/ paragraphs (when tenderer plans to give separate compliance of each paragraph or sub clause) of tender document

**5. Earnest Money Deposit**

- 5.1 The tenderer shall furnish an amount as given in Preamble as earnest money in favour of RailTel Corporation of India Limited for each tendered section that he wants to quote for.
- 5.2 The validity of offer will be 120 days from the date of opening of tender 'as given in Preamble. It being understood that the tender documents have been sold/issued to the tenderer and the tenderer has been permitted to tender in consideration of the stipulation on his part that after submitting his tender he will not resile from his offer or modify the terms and conditions there of in a manner not acceptable to RailTel. If the tenderer fails to observe or comply with the foregoing stipulation, action to be taken as mentioned in Annexure-B-2.
- 5.3 The Earnest Money receipt shall be incorporated in the original copy of the tender document. Other copies of the offer shall contain true copies of Earnest Money receipt. The Earnest Money should be furnished through net banking in favour of M/s. RailTel Corporation of India Limited, Eastern Region, Kolkata.

- 5.4 The earnest money may be forfeited under the following circumstances.
- 5.4.1 If tenderer withdraw its tender during the period of tender validity specified in Preamble
- 5.4.2 In case of successful tenderer, if the tenderer fails to sign the contract in accordance with relevant para of Preamble and to furnish Performance Guarantee amount in accordance with relevant clause of preamble. The earnest money of unsuccessful tenderer will save as herein before provided, be returned within reasonable time to the unsuccessful tenderer but the RailTel shall not be responsible for any loss or depreciation that may happen to the security for the due performance of the above stipulation to keep offer open for the period specified in the tender documents or to the Earnest Money while in their possession or be liable to pay interest there on.
- 5.5 If the tender is accepted, the amount of Earnest Money, if available will be returned to the bidder as per relevant para of Preamble of tender document after receiving of Performance Guarantee Amount.
- 5.6 The tender not accompanied by Earnest Money as mentioned in clause 5.3 above or if any of the documents submitted by the tenderers is proved to be fraudulent, the offer will be summarily rejected & EMD will be forfeited.
- 5.7 The Performance Guarantee Amount shall be released as per relevant clause of preamble.
- 5.8 **NSIC registered Firm and micro and small enterprises (MSEs):**
- 5.8.1. For NSIC registered firm and micro and small enterprises (MSEs) who are having valid Udyog Aadhar Memorandum and for small scale units and micro units registered with NSIC under single point registration Scheme and participating in this tender enquiry, following exemptions are available:-
- (i) They shall be exempted from cost of tender documents.- Not Applicable
- (ii) They shall also be exempted from depositing Earnest Money.
- (iii) **Purchase preference to MSEs:**

Purchase preference will be given to MSEs as defined in Public Procurement Policy for Micro and Small Enterprises (MSEs) Order, 2012 dated 23.03.2012 issued by Ministry of Micro, Small and Medium Enterprises and its subsequent Orders/Notifications issued by concerned Ministry. If the bidder wants to avail the Purchase preference, the bidder must be the manufacturer of the offered product in case of bid for supply of goods. Traders are excluded from the purview of Public Procurement Policy for Micro and Small Enterprises. In respect of bid for Services, the bidder must be the Service provider of the offered Service. Relevant documentary evidence in this regard shall be uploaded along with the bid in respect of the offered product or service. If L-1 is not an MSE and MSE Seller (s) has/have quoted price within L-1+ 15% of margin of purchase preference /price band defined in relevant policy, such Seller shall be given opportunity to match L-1 price and contract will be awarded.

These exemptions shall be applicable provided units are registered with NSIC/MSEs for tendered item and registration is current and valid. Firms claiming these exemptions are required to submit along with their offer, a copy of their current and valid NSIC registration certificate/ Udyog Aadhar Memorandum for the tendered item/items, otherwise their offer would not be considered.

5.8.2 No exemption is, however, applicable to these units from payment of Performance Guarantee Amount. **Micro and Small Enterprises (MSEs):**

- i. Micro and Small Enterprises (MSEs) registered with NSIC or any other body specified by Ministry of MSME is exempted from submission of the following:  
(i) They shall be exempted from submission of cost of tender document (ii) They shall be exempted from submission Earnest Money Deposit.

**However, firms claiming the above exemptions shall submit bid security declaration as per format enclosed at Annexure-B-2. The exemption for Micro and Small Enterprises (MSEs) will be granted solely on the basis of the most recent UDYAM Aadhaar generated on or after July' 1, 2020, obtained from the MSME website.**

- ii. MSEs claiming for the above exemptions under NSIC/MSME or others, have to submit supporting documents These exemptions shall be applicable provided firms are registered with NSIC/MSME registration is current and valid. Firms claiming these exemptions are required to submit along with their offer, a copy of their current and valid NSIC/MSME registration certificate otherwise their offer would not be considered.
- iii. RailTel is registered with m1xchange TReDS Platform having Buyer registration Number "BUYER00001496". The URL for m1xchange Platform is <https://www.m1xchange.com>. MSE suppliers/vendors are required to register themselves on m1xchange Platform for availing the facility of bill discounting on TReDS portal. The bidder is mandatorily required to submit its TReDS registration number (as provided by M1xchange portal) and GRN (Goods/Service Receipt Note) Number (as provided by RailTel on delivery of Goods/Service) while submitting the invoices if requires to avail TReDS facility
- iv. MSE Vendor will bear all costs relating to availing the facility of discounting on TReDS platform including but not limited to Registration charges, Transaction charges for financing, Discounting Charges, Interest on financing, or any other charges known by any name shall be borne by MSE Vendor.
- v. MSE Vendor hereby agrees to indemnify, hold harmless and keep RailTel and its affiliates, Directors, officers, representatives, agents and employees indemnified, from any and all damages, losses, claims and liabilities (including legal costs) which may arise from Sellers submission, posting or display, participation, in any manner on the TReDS Platform or from the use of Services or from the Buyer's breach of any of the terms and conditions of the Usage Terms or of this Agreement and any Applicable Law on a full indemnity basis.
- vi. RailTel shall not be liable for any special, indirect, punitive, incidental or consequential damages or any damages whatsoever (including but not limited to

damages for loss or profits or savings, business interruption, loss of information), whether in contract, tort, equity or otherwise or any other damages resulting from using TReDS platform for discounting their (MSE Vendor's) invoices.

## **6. SUBMISSION OF OFFERS**

- 6.1 The offer in the prescribed forms should be submitted before the time and date fixed for the receipt of the offers. Offers received after the stipulated time and date will be summarily rejected.
- 6.2 In case the date of opening happens to be a holiday, the tender will be received and opened at the same time on the next working day.
- 6.3 The offer shall be either type written or written neatly in indelible ink in English. Each page of the offer must be numbered consecutively. A reference to total number of pages comprising the offer must be made at the top right hand corner of the top page. The supporting documents should be submitted either in original or duly signed/ digitally signed by the authorized signatory of the tenderer. The original documents shall be produced for verification when called for.
- 6.4 All copies of the tender papers shall be signed/ digitally signed by the tenderer, on each page including closing page in token of his having studied the tender papers carefully.

### **6.5 RATES IN FIGURES & WORDS:**

- i) All prices having a bearing on the quoted price shall be written both in figures and in words in the prescribed offer form. In case of difference in words and figures the amount written in words will be taken into consideration.
- ii) In the event of any discrepancy between unit rate and total cost, the value shown in unit rate will be taken for evaluation purpose.
- iii) In case the schedule of requirement quoted by tenderer is incomplete with reference to tender document, the offer is liable to be rejected.

### **6.6 ATTESTATION OF ALTERATION:**

No scribbling is permissible in the tender documents. Tender containing erasures and alterations in the tender documents are liable to be rejected. Any correction made by the tenderer/tenderers in his/their entries must be signed/ digitally signed (not initialed) by him/them.

- 6.7 Submission of tender BID will be done as per relevant para of Preamble.

## **7. UNIT PRICES:**

Unit prices should be quoted in Indian Rupees by the tenderer after taking all the relevant factors into consideration and these should be Firm and all including of GST without any variation clauses. The prices shall be quoted in rupees for the units under metric system.

**8. VALIDITY OF OFFER**

The tenderer should keep the offers valid for the period as mentioned in “Preamble”.

**9. RATES DURING NEGOTIATION**

The tenderer/s shall not increase his/their quoted rates in case the RailTel Administration negotiates for reduction of rates. Such negotiations shall not amount to cancellation or withdrawal of the original offer and the rates originally quoted will be binding on the tenderer/s.

**10. OPENING OF TENDER:**

Tenderer’s Bid will be opened online at the time & date of opening of the tender given in relevant para of preamble in presence of such Tenderers/Authorized Representatives who choose to be present.

**11. NON-TRANSFERABILITY AND NON-REFUNDABILITY**

The tender documents are not transferable. The cost of tender paper is not refundable.

**12. ERRORS, OMISSIONS & DISCREPANCIES**

The Contractor(s) shall not take any advantage of any miss-interpretation of the conditions due to typing or any other error and if in doubt, shall bring it to the notice of the Engineer In charge without delay. In case of any contradiction only the printed rules, and books should be followed and no claim for the miss-interpretation shall be entertained.

**13. WRONG INFORMATION BY TENDERER**

If the tenderer/s deliberately gives/give wrong information in his/their tender which creates/create circumstances for the acceptance of his/their tender, action to be taken as mentioned in the Annexure-B-2. Also, if the wrong information leads to release of any wrong payment, the contract will be cancelled and Performance Guarantee Amount will be encased.

**14. QUALIFYING CRITERIA**

For qualifying in tenderers bid shall be required to meet the eligibility requirements as given in relevant para of preamble.

**15. SYSTEM PERFORMANCE GUARANTEE**

The Contractor shall give unqualified and unconditional guarantee that the maintenance team deployed by him will achieve desired objective, if he needs to depute any additional Man, Machine & Material to achieve desired objective, no extra payment shall be made to the contractor. Amount as defined in the preamble will be held towards the same.

**16. EVALUATION OF OFFER**

The tenders received will be evaluated by the Authorized representative of RailTel

as per eligibility & evaluation criteria given in the tender document.

However, the RailTel shall not be bound to accept the lowest or any tender or to as sign any reason for non-acceptance or rejection of a tender. The purchaser reserves the right to accept any tender in respect of the whole or any portion of the work specified in the tender document.

**17. AGREEMENT**

The successful tenderer/s shall be required to sign agreement with the representative of RailTel for carrying out the work according to the tender documents within 15 days as indicated in relevant para of preamble.

**18. TENDERER'S ADDRESS**

Tenderer shall state in the tender his postal address fully and clearly. Any \*communication sent to the tenderers by post at his said address shall be deemed to have reached the tenderer duly & timely, notwithstanding the fact that the communication could not reach the tenderer at all or in time for whatever reason. Important documents shall be sent by Registered Post and will be dealt as per relevant para of preamble

**19. SETTLEMENT OF DISPUTES/ ARBITRATION**

Any dispute or difference whatsoever arising between the parties out of or relating to the construction, meaning, scope of work, operation, rates, penalties or effect of this contract or the validity or the breach thereof, shall be settled by arbitration in accordance with the Arbitration and Conciliation Act 1996 as amended and the award made in pursuance thereof shall be binding on both the parties. The venue of such arbitration or proceedings thereof shall be at New Delhi.

All arbitration proceedings shall be conducted in English. Recourse against any arbitral award so rendered may be entered into court having jurisdiction or application may be made to such court for the order of enforcement as the case may be.

The arbitral Tribunal shall consist of the sole arbitrator appointed by CMD/RailTel Corporation of India Limited, if the value of claim is up to Rs. 10 lakh. If the value of claim or amount under dispute is more than 10 lakhs, the matter shall be referred to the adjudication of arbitral council. CMD/RailTel Corporation of India Limited shall furnish a panel of three names to the contractor, out of which, contractor will recommend one name to be his nominee and then CMD/RailTel shall appoint one name as RailTel's nominee and these two arbitrators with mutual consent shall appoint a third arbitrator who shall act as the deciding arbitrator in terms of Arbitration and Conciliation Act. The award of the sole arbitrator or the Arbitral council, as the case may be, shall be final and binding on both the parties. Each of the parties agree that notwithstanding that the matter may be referred to Arbitrator as provided herein, the parties shall nevertheless pending the resolution of the Controversy or disagreement, continue to fulfill their obligation under this agreement so far as they are reasonable able to do so.

## **Chapter-13**

### **SPECIAL CONDITIONS OF CONTRACT**

#### **INDEX**

**PARA      SUBJECT**

- 1.      TENDER DOCUMENTS**
- 2.      AGREEMENT**
- 3.      CONTRACT PERFORMANCE GUARANTEE**
- 4.      CONTRACTOR'S OFFICE**
- 5.      PROGRAMME OF WORK.**
- 6.      COMPETENT SUPERVISORS**
- 7.      TEST & MEASURING INSTRUMENTS AND SPECIAL TOOLS ETC**
- 8.      STORES TO BE SUPPLIED BY CONTRACTOR**
- 9.      SPARES**
- 10.    QUALITY ASSURANCE**
- 11.    INSPECTION OF MAN, MACHINE & MATERIALS**
- 12.    SUBLETTING AND ASSIGNMENT**
- 13.    EXECUTION OF WORK**
- 14.    MAINTENANCE OF WORKS**
- 15.    CLEARANCE OF SITE**
- 16.    WARRANTY SUPPORT**
- 17.    INFRINGEMENT OF PATENTS**
- 18.    LABOUR LICENCE & COMPLIANCE WITH LABOUR, INDUSTRIAL & ENVIRONMENTAL LAWS**

- 19. DEFAULTS AND DELAYS**
- 20. LOSS SUSTAINED DUE TO DEFAULTS AND DELAYS**
- 21. CONTRACTOR'S LIABILITIES FOR COSTS AND DAMAGES**
- 22. UNIT PRICES**
- 23. TERMS OF PAYMENTS**
- 24. FINAL SETTLEMENT**
- 25. TAXES**
- 26. INSURANCE FOR WORKMEN & MATERIALS**
- 27. FORCE MAJEURE CLAUSE**
- 28. SETTLEMENT OF DISPUTE AND ARBITRATION**
- 29. TERMINATION OF CONTRACT**



रेलटेल  
RAILTEL

RailTel Corporation of India Ltd.

(A Ministry Category - I Enterprise)

**SPECIAL CONDITIONS OF CONTRACT**

**1. TENDER DOCUMENTS**

- 1.1 The services and quality required, bidding procedure and contract terms and conditions are prescribed in the tender documents. The set of tender documents issued for the purpose of bidding includes following together with Corrigendum and Addendum, if any.

Section-I: I) Preamble.  
II) Checklist & tender notice  
III) Introduction, scope of work

Section-II: I) Instructions to tenderers and conditions of tendering.  
II) Special conditions of contract  
III) Forms, proformas & Drawing of Tender

- 1.2 If the Tender submitted by a Tenderer is accepted and the contract awarded to the Tenderer the various works/Contracts coming under the purview of the contract shall be governed by tender documents.
- 1.3 Any special conditions stated by the Tenderer in the covering letter submitted along with the tender shall be deemed to be a part of the Contract to such extent only as have been explicitly accepted by the RailTel.

**2. AGREEMENT**

The successful Tenderer shall, within 15 days after having been called upon by notice to do so, be bound to execute an agreement based on accepted rates, terms and conditions, in such form as the RailTel may prescribe, and lodge the same with the RailTel together with the conditions of contract, specifications and Schedule of prices referred to therein duly completed. The form for agreement is referred as Form no. 1.

**3. CONTRACT PERFORMANCE GUARANTEE**

- 3.1 On receipt of the Letter of Acceptance of Tender from the RailTel, the successful Tenderer shall deposit an amount to RailTel as defined as per relevant para of preamble rounded off the nearest whole number towards payment of Performance Guarantee Amount for due fulfillment of the contract.
- 3.2 Details as to how SD will be deposited and released are given in the preamble.

**4. CONTRACTOR'S OFFICE**

Tenderer shall state in the tender his postal address fully and clearly. Any communication sent to the tenderers by post at his said address shall be deemed to have reached the tenderer duly & timely, notwithstanding the fact that the communication could not reach the tenderer at all or in time for whatever reason. Important documents shall be sent by Registered Post and will be dealt as per relevant para of preamble.

**5. PROGRAMME OF WORK**

- 5.1 The Contractor shall have necessary resources to execute the work/contract so that the entire work is completed within two year period as mentioned in the relevant para of preamble from the date of issue of Letter of Acceptance of the tender.
- 5.2 Contractor has to commence work within 21 days from the date of issue of Letter of acceptance.
- 5.3 The Contractor shall be held responsible for the execution of the work/contracts according to the various clauses of the Technical specifications, instructions/drawingsetc. as per tender conditions. Failure to comply with any of these will be dealt with as per provision laid down in Conditions of Tendering.
- 5.4 The contractor will program his work/contract in such a manner so as not to interfere in the working telecom circuits and movement of trains.

**6. COMPETENT SUPERVISORS**

The CONTRACTOR shall depute experienced / competent representative(s) at site during the execution of any job. Any instructions given to such representative(s) shall be construed as having been given to the CONTRACTOR

**7. TEST & MEASURING INSTRUMENTS AND TOOLS ETC.**

The CONTRACTOR shall be totally responsible for the calibration & functionality of test equipment to be used at site as per laid down procedure in tender document.

**8. STORES TO BE SUPPLIED BY CONTRACTOR**

All materials required for the execution of the contract shall be arranged and supplied by the Contractor except supply of Duct and OFC so as to realize the end objective.

**9. SPARES**

The tenderer shall keep spare man, machine and material to achieve the end objective of work. This will be on the own cost of contractor.

**10. QUALITY ASSURANCE**

Quality of service to be performed should be to entire satisfaction of RailTel, in case the services are not found up to the mark or failure to execute the work as per terms & conditions of the contract, RailTel will get the work done from other sources at contractor's cost.

**11. INSPECTION OF Man, Machine & Work**

The Executive Director or his representative may inspect and test the various portions of the work / contract at all stages and shall have full power to reject all or any portion of the work that he may consider to be defective or inferior in quality of materials, machine & workmanship or design in comparison to what is called for in the specification. Periodicity will be as defined in O&M manual.

**12. SUBLETTING AND ASSIGNMENT**

The contractor shall not sub-contract whole or any part of the work.

**13. EXECUTION OF WORK**

All the works/Contract shall be executed in strict conformity to the provisions of the contract document and with such explanatory detailed drawings, specifications and instructions as may be approved from time to time based on detailed design and engineering carried out by contractor in line with requirements as per contract document. The contractor shall be responsible for ensuring that the work throughout are executed in the most substantial, proper and workman like manner with the quality of material and workmanship in strict accordance with the specifications and as per sound industrial practices and to the entries' at its faction of the RailTel.

**14. MAINTENANCE OF WORKS /CONTRACTS**

The maintenace of section is to be done as per the laid down terms and conditions in the contract agreement to achieve the end objective of the contract

**15. CLEARANCE OF SITE**

At the end of the work at each location the Contractor shall as a part of his Contractual obligation, leave the section completely neat and clean.

**16. WARRANTY**

16.1 All material supplied/used and the work done by the contactor shall be guaranteed for 24 months against the defective manufacture/workmanship, within warranty period from the date of rectification. The cost of work and material under

warranty found to be defective will be recovered from the SD.

**17. INFRINGEMENT OF PATENTS:**

- (a) The Contractor is forbidden to use any patents or registered drawings, processes or patterns in fulfilling his contract without prior consent in writing of the owner of such patents, drawings, patterns or trademarks except where these are specified by the Executive Director himself. Royalties where payable for the use of such patented processes, registered drawings or patterns shall be borne exclusively by the Contractor. The Contractor shall advise the Executive Director or its representatives of any proprietary rights that may exist on such processes, drawings or patterns which he may use of his own accord.
- (b) In the case of patents taken out by the Contractor of the drawings or patterns registered by him or of those patents, drawings or patterns for which he holds a license, the signing of the contract automatically gives the Executive Director or its representatives the right to repair by himself for services covered by the patent or by any person or body chosen by him and to obtain from any sources he desires the component parts required by him for carrying out the repair work. In the event of infringement of any patent rights due to above action of the Executive Director, he shall be entitled to claim damages from the Contractor on the grounds of any loss of any nature which he may suffer e.g.in the case of attachment because of counterfeiting.

**18. LABOUR LICENSE and COMPLIANCE WITH LABOUR, INDUSTRIAL & ENVIRONMENTAL LAWS**

**18.1** The Contractors are required to produce license as enjoined in the Government of India Contract Labour(Regulation and Abolition) Act (1978) with latest amendments, if any. The Contractor shall at its expense, ensure due compliance with all applicable and governing Industrial, environmental and Labour Laws, Rules, Regulations and Bye-laws both of the Central and State Govt. and all other local authorities and shall keep RailTel harmless and indemnified in respect thereof. The CONTRACTOR shall ensure due compliance with the provisions of the relevant minimum Wages Act, payment of Wages, Contract Labour (Regulations & Abolition) Act, Employees Provident Fund Act and other industrial and environmental laws in force and provide any related information to RailTel as and when required.

**18.2.** A Contractor is to abide by the provisions of payment of wages act & minimum wages act in terms of clause 54 and 55 of Indian Railways General Condition of Contract. In order to ensure the same, an application has been developed and hosted on website '[www.shramikkalyan.indianrailways.gov.in](http://www.shramikkalyan.indianrailways.gov.in)'. Contractor shall register his firm /company etc. and upload requisite details of labor and their payment in this portal. These details shall be available in public domain. The Registration/ updation of portal shall be done as under:

- (a) Contractor shall apply for onetime registration of his company/ firm etc. in the Shramik Kalyan Portal with requisite details subsequent to issue of letter of Acceptance. Engineer shall approve the contractor's registration on the portal within 7 days of receipt of such request.
  - (b) Contractor once approved by any Engineer, can create password with login ID (PAN No.) for subsequent use of portal for all LoAs issued in his favour.
  - (c) The contractor once registered on the portal, shall provide details of his letter of Acceptances (LoA/ Contract Agreements) on Shramik Kalyan Portal within 15 days of issue of any LoA for approval of concerned Engineer. Engineer shall update (if required) and approve the details of LoA filled by contractor within 7 days of reflection of such request.
  - (d) After approval of LoA by Engineer, contractor shall fill the salient details of contract labours engaged in the contract and ensure updating of each wage payment to them on Shramik Kalyan Portal on monthly basis.
  - (e) It shall be mandatory upon the contractor to ensure correct and prompt uploading of all salient details of engaged contractual labour & payment made thereof after each wage period.
- 18.2.B** While processing payment of any 'On Account Bill' or 'Final Bill' or release of 'Advance' or 'Performance Guarantee' contractor shall submit a certificate to the Engineer or Engineer's representative that "I have uploaded the correct details of contract labour engaged in connection with this contract and payment made to them during the wage period in Railway's Shramik Kalyan Portal at 'www.shramikkalyan.indianrailways.gov.in' till \_\_\_\_\_ Month, \_\_\_\_\_ Year.

## **19. DEFAULTS AND DELAYS**

The Contractor shall execute the work with due diligence and expedition, keeping to the proper maintenance. Should he refuse or neglect to comply with any reasonable orders given to him in writing by the Rail Tel's engineer in connection with the work or contravene the provision of the Contractor the progress of work lags persistently behind the time schedule due to his neglect, the contract will be terminated as per the condition given in the SCC.

## **20. LOSS SUSTAINED DUE TO DEFAULTS AND DELAYS**

In the event of any loss or damages to RailTel and other parties on account of execution and/or completion of the work or any part thereof by the contractor, He may become defaulter and penalties shall be borne by Contractor itself as per various clauses defined in the tender document.

## **21. CONTRACTOR'S LIABILITIES FOR COSTS AND DAMAGES**

- 21.1 Whenever any claim or claims for payment arises out of or under the contract

against the contractor, the Executive Director or its representatives shall be entitled to withhold and also have lien to retain such sum or sums in whole or in part thereof. The contractor shall be charged a penalty as defined in tender document. .

- 21.2 The Maximum Liability of contractor to any Loss/Damages to RailTel including Liquidity Damages and Performance Bond shall be limited to 100% of Value of contract.

## **22. UNIT PRICES**

- 22.1 The prices quoted by the Tenderer shall include the prices of Man, Machine & materials including all other charges. The prices would also include charges towards completing all necessary formalities such as submission of forwarding notes, banker's charges for Bank guarantee, Indemnity Bonds inclusive of cost of Stamp etc. as applicable and also the charges, if any, levied by the RailTel.

- 22.2 **TAXES, DUTIES, OCTROI, LEVIES ETC:** The quoted prices shall be including GST till the completion of the contract and the CONTRACTOR shall not be eligible for any compensation on any account. Any change in GST rates shall be paid as per actual.

- 22.3 The prices quoted in the contract shall be inclusive of all other taxes i.e. Income tax, custom duty, excise duty, octroi, local levies, sales tax levied by any statutory authority, GST TDS, Labour Cess, VAT (if any) or any other tax, incl. GST. The tenderer will indicate the details of taxes included in the unit price. The rate of GST applicable on the basic rates should also be mentioned.

## **23. TERMS OF PAYMENT**

- 23.1 For this tender, Bill Passing authority is Sr. DGM/O&M and Bill Paying Authority is the Head of Finance/ RailTel/Eastern Region. All bills shall be submitted to the authority concerned in Regional Office of RailTel.
- 23.2 Even though the maintenance charges are worked out on a monthly basis. The CONTRACTOR shall be paid once in two months the maintenance charges for two months period subject to submission of permanent restoration certificate (proforma -7) of fault occurred during the particular period jointly signed by RAILTEL & contractor representatives and on submission of test results of power, OTDR readings etc. as required by the terms of the contract to the satisfaction of the Engineer.
- 23.3 Submission of bills within 15 days or by next week for previously completed two months is mandatory failing of which a penalty shall be charged as defined in tender document. Deduction from monthly maintenance charges if the Cumulative repair time of the faults in each billing period of consecutive two months exceeds by 2 hours or part thereof.

- 23.4 The amount payable against the maintenance charges is dependent upon the Cumulative Repair Time taken by the Contractor for the restoration of all OFC link cut/faults occurred during each billing period of consecutive two months. Cumulative repair time does not include the down time taken for planned works like diversion of OFC, re-termination etc.
- 23.5 ON ACCOUNT PAYMENT FOR Submission of documents : Along with the bill for payments for the respective sections, the documents as defined in tender document must be submitted duly certified by the RailTel's representative.
- 23.6 GST related clauses:
- a. The price quoted in the offer should be firm, fixed indicating the breakup and inclusive of all taxes & duties like import, custom, Anti-Dumping, incl. GST (CGST, SGST, IGST, UTGST etc.). The offer should be inclusive of packing, forwarding, freight up to destination, insurance charges
  - b. Bidder shall issue valid tax invoice to RailTel for availing proper credit of CGST/SGST/IGST/UTGST in case of award of contract. GST will not be reimbursed in the absence of valid tax invoice.
  - c. For all the taxable supplies made by the vendor, the vendor shall furnish all the details of such taxable supplies in the relevant returns to be filed under GST Act.
  - d. If the vendor fails to comply with any of the above, the vendor shall pay to purchaser any expense, interest, penalty as applicable under the GST Act.
  - e. In case of incorrect reporting of the supply made by the vendor in the relevant return, leading to disallowance of input credit to purchaser, the vendor shall be liable to pay applicable interest under the GST Act to the credit of purchaser. The same provisions shall be applicable in case of debit/credit notes.
  - f. Tenderer shall quote basic rates, but there shall be break up all type of applicable taxes such as SGST/CGST/IGST/UT GST along with respective HSN/SAC Code under GST Law (including tax under reverse charges payable by the recipient).
  - g. Wherever the law makes it statutory for the Purchaser to deduct any amount towards GST at sources, the same will be deducted and remitted to the concerned authority.
  - h. In regards to works contract, the tenderer should have registration no. for GST in respective state where work is to be executed and shall furnish GST registration certificate along with Tender.
  - i. The imposition of any new tax and/or increase/in the aforesaid taxes, duties levies, after the last stipulated date for the receipt of tender of tender including extensions if any and the bidder there upon necessarily and properly pays such taxes/levies/cess, the bidder shall be reimbursed the amount so paid, provided such payments, if any, is not, in the opinion of RailTel attributable to delay in execution of work within the control of the bidder. The bidder shall, within a period of 30 days of the imposition of any such tax or levy or cess, give a written notice thereof to RailTel that the same is given pursuant to this condition, together will all necessary information including details of input credit relating thereto. In the event of non-payment/default in payment of any of the above taxes, RailTel reserves the right to with-hold the dues/payments of bidder and make payment to State/Central Government authorities as may be applicable. However, if the rates are reduced after the last stipulated date for receipt of tender, bidder has to pass on the benefits to RailTel.

- j. In case the successful tenderer is not liable to be registered under CGST/IGST/UTGST/SGST act, the RailTel shall deduct the applicable GST from his/their bills under Reverse charge Mechanism(RCM)and deposit the same to the concerned Tax Authority.

**24 FINAL SETTLEMENT**

Performance Guarantee Amount shall be returned to the contractor as per relevant paras of preamble.

**25. TAXES**

- 25.1 The Contractor and all personnel employed by him shall pay such taxes like Income Tax, Labour Cess etc as are payable under statutory laws of India and the RailTel WILL NOT ACCEPT any liability for the same.
- 25.2 Deduction of Income Tax at source, Labour Cess, GST as per provisions of Finance Act and Income Tax law shall be made from the Contractor/Sub-Contractor and the amounts of deducted may be credited to the Central Government.
- 25.3 Wherever the law makes it statutory for the Executive Director or its representatives to deduct any amount towards Sales Tax on Works Contract, the same will be deducted and remitted to the concerned authority.

**26 INSURANCE OF MATERIALS**

The Contractor shall take out and keep in force a Policy or policies of Insurance for all machine & materials including RailTel supply materials/equipments.

- 26.1 The Contractor should, however, insure the stores brought to HQ, site, against risks in consequence of war and invasion, as required under the Emergency Risk(Goods) Insurance Act on force from time to time.
- 26.2 It may be noted that the beneficiary of the insurance policy should be RailTel or the policies should be pledged in favour of RailTel. The contractor shall keep the policy/policies current till the completion of the contract.
- 26.3 For the purpose of enabling the contractor to take the insurance cover in connection with this contract, the Executive Director or its representatives will advise the approximate price of all the RailTel supply materials to the Contractor.

**27. FORCE MAJEURE CLAUSE**

If at anytime, during the continuance of this Contract, there are delays or some jobs are not performed, which are on account of any war, hostility, act of the public enemy, Civil Commotion, Sabotage, Fires, Floods, Earth quakes, explosions, strikes, epidemics, lockouts, any statute, statutory rules / regulations, order of acquisitions issued by any Government Department or Competent Authority etc. Or acts of God, then such delays or non-completion of jobs will not be counted as non-performance of the contract & will also not attract attendant penalties.

**28. SETTLEMENT OF DISPUTE AND ARBITRATION**

- 28.1 Any dispute or difference what so ever arising between the parties out of or relating to the construction, meaning, scope, operation or effect of this contract or the validity or the breach thereof shall be settled by arbitration in accordance with the Arbitration and Conciliation Act, 1996 as amended and the award made in pursuance there of shall be binding on the parties. The venue of such arbitration or proceedings thereof shall be New

Delhi.

28.2 All arbitration proceedings shall be conducted in English. Recourse against any Arbitral award so rendered may be entered into court having jurisdiction or application may be made to such court for the order of enforcement as the case may be.

**29. TERMINATION OF CONTRACT OWING TO DEFAULT OF CONTRACTOR:**

29.1 If the Contractor should:

- (i) Become bankrupt or insolvent
- (ii) If contractor, subcontract whole or any part of the work.
- (iii) Abandon the contract
- (iv) Persistently disregard the instructions of the RailTel's Engineer or contravene any provision of the contract, or
- (v) fail to provide man, machine & material and/or carry out the works as per contractual specifications,
- (vi) Is a defaulter as per relevant clause of condition of contract?
- (vii) Promise offer or give any bribe, commission, gift or advantage either himself or through his partner, agent or servant to any officer or employee of RailTel or any person on his or on their behalf in relation to the execution of this or any other contract with the RailTel,
- (viii) In RailTel's opinion, the cessation of work become necessary, owing to paucity of funds of the Contractor, the Contractor's apparent inability to perform, non possession of equipments and tools required for the work or defective and malfunctioning equipments, non-availability of proper/nominated instrumentation, inability to provide men and material, repeated slippages and payment of penalty thereof or for any other cause deemed reasonable.

Then and in any of these said cases, the Engineer on behalf of the RailTel may serve the Contractor with a 30 days' notice in writing to that effect terminate the contract.

29.2 In such case, the value of approved materials utilized at site and of certified and accepted work done to date by the Contractor as per contract agreement shall be paid for in full at the rates specified in the Contract subject to the clause of Liquidated damages contemplated herein. All such materials become the property of the RailTel. Notice in writing from the RailTel of such termination and reason thereof shall be conclusive evidence of taking over of works from the contractor. Full Performance Guarantee Amount will be encased in such case of termination.

The contractor shall be debarred from participating in the tender for executing the balance work.

29.3 Contractors defaulting in one section and having their contract terminated will not be allowed to participate in RailTel's next O & M tender for a period of 3 years in any of it's regions.

**29.4 RIGHT OF RAILTEL AFTER TERMINATION OF CONTRACT OWING TO DEFAULT OF CONTRACTOR:**

In the event of any or several of the courses, referred to above, being adopted:

- (a) The Contractor shall have no claim to compensation for any loss sustained by him by reason of his having purchased or procured any Man, Machine & materials or entered into any commitments or made any advances on account of or with a view to the execution of the works or the performance of the contract and Contractor shall not be entitled to recover or be paid any sum for any works there to not actually performed under the contract, unless or until the Engineer shall have certified the performance of such work and the value payable in respect thereof and the Contractor shall only be entitled to be paid the value so certified.
- (b) The Engineer shall be entitled to take possession of any materials, tools, implements, machinery or buildings on the works or on the property on which these are being or ought to have been executed, and to retain the employ the same in the further execution of the works or any part thereof until the completion of the works without the Contractor being entitled to any compensation for the use and employment thereof or for wear and tear or destruction thereof.
- (c) The RailTel shall not be liable to pay to the Contractor any moneys on account of the contract until the satisfactorily completion of work duly verified by RailTel representative. The Contractor shall have no claim to any payment of compensation or otherwise how sever on account of any profit or advantage which he might have derived from execution of the work in full but he did not derive in consequence of termination of the contract.

रेलटेल  
RAILTEL

RailTel Corporation of India Ltd.

(A Multinational Category - 1 Enterprise)

**Chapter-14****Forms & Proforma****Form-I****AGREEMENT**

An AGREEMENT made this \_\_\_\_\_ day of \_\_\_\_\_ Year, between RailTel Corporation of India Limited, having its registered office at Plate-A, 6th Floor, Office Tower-2, NBCC Building, East Kidwai Nagar, New Delhi-110023 and regional office at RailTel Corporation of India Ltd, Eastern Region with full address....., acting in the premises through Regional General Manager or his successor \_\_\_\_\_ of M/s. RailTel Corporation of India Limited, Eastern Region (hereinafter referred to as 'RailTel') of one part and M/s \_\_\_\_\_ (Name and Full Address of Firm (Registered and regional office address) (hereinafter referred to as 'contractor') of the other part.

Whereas in response to a call for Tender for \_\_\_\_\_ **Name of Work**] as per Tender Document at **Annexure 'B'** hereto the Contractor has submitted a Tender here to and whereas the said Tender of the Contractor has been accepted for \_\_\_\_\_

\_\_\_\_\_ [ **Name of Work** ]  
as per copy of **Letter of Acceptance No.** \_\_\_\_\_ **dated** \_\_\_\_\_ of **GeM Bid No.** \_\_\_\_\_ **dated** \_\_\_\_\_ (**Tender Notice date**) complete with enclosures at the accepted rates and agreed deviations from Tender Papers as per **Annexure-C** hereto and at an estimated contract value of Rs. \_\_\_\_\_ (Rupees \_\_\_\_\_ Only).

Now this agreement witnesses that in consideration of the premises and the payment to be made by the Purchaser to the Contractor provided for herein below the Contractor shall supply all equipment and materials and execute and perform all works for which the said Tender of the Contractor has been accepted strictly according to the various provisions in Annexure 'A', 'B' hereto and upon such supply, execute and performance to the satisfaction of the purchaser and the purchaser shall pay to the Contractor at the rates accepted as per the said Annexure 'A' and in terms of the provisions therein.

In the witness where of the parties have hereunto set and subscribed their respective hands and/or seals day and year respectively mentioned against their respective signatures.

Signed and delivered at \_\_\_\_\_ by Shri \_\_\_\_\_ for and on behalf of M/s. \_\_\_\_\_

The contractor within named in the presence of:

1. Signatures

Date  
Name in Block Capitals  
Address

2. Signatures  
Date  
Name in Block Capitals  
Address

Signed and delivered at \_\_\_\_\_ for and on behalf of  
RailTel by Shri \_\_\_\_\_ (Director / Projects or his successor) in the  
presence of:-

1. Signatures  
Date  
Name in Block Capitals
2. Signature  
Date  
Name in Block Capitals

**Annexure 'A': Copy of Letter of Acceptance & GeM Contract**

**Annexure 'B': Tender Document**

**Annexure 'C': Details of Performance Guarantee Amount**

RailTel Corporation of India Ltd.

(A Multinational Category - Enterprise)

**Proforma for Performance Bank Guarantee**

**(To be stamped in accordance with stamp act)**

**(To be used by approved Indian Scheduled commercial banks( either Private or PSU)  
but not from any Cooperative banks or NBFC)**

In consideration of the RailTel Corporation of India Limited, registered office at Plate-A, 6th Floor, Office Tower-2, NBCC Building, East Kidwai Nagar, New Delhi-110023 and regional office at RailTel Corporation of India Ltd, Eastern Region, 19<sup>th</sup> floor, Aurora waterfront, GN 34/1, Block- GN, Sector –V, Salt Lake, Bidhannagar, Kolkata-700091, West Bengal

1. (Herein after called RailTel) having agreed to exempt ..... (Hereinafter called “the said Contractor(s)”) from the demand, under the terms and conditions of an Agreement No. .... dated ..... made between ..... and ..... for (hereinafter called “the said Agreement”) of Performance Guarantee for the due fulfillment by the said Contractor (s) of the terms and conditions contained in the said Agreement, or production of a Bank Guarantee for Rs. .... (Rs. .... only). We, .....(indicate the name of the Bank) hereinafter referred to as “ the Bank”) at the request of ..... Contractor(s) do hereby undertake to pay the RailTel an amount not exceeding Rs. .... Against any loss or damage caused to or suffered or would be caused to or suffered by the RailTel by reason of any breach by the said Contractor(s) of any of the terms or conditions contained in the said Agreement.
  
2. We, ..... Bank **and our local branch at Kolkata (indicate detail address of local Kolkata Branch with code no.)** do hereby undertake to pay the amounts due and payable under this Guarantee without any demur, merely on demand from the RailTel stating that the amount is claimed is due by way of loss or damage caused to or would be caused to or suffered by the RailTel by reason of breach by the said Contractor(s) of any of terms or conditions contained in the said Agreement or by reason of the Contractor(s) failure to perform the said Agreement. Any such demand made on the Bank shall be conclusive as regards the amount due and payable by the Bank under this guarantee. However, our liability under this guarantee shall be restricted to an amount not exceeding Rs. ....
  
3. We, ..... bank undertake to pay to the RailTel any money so demanded notwithstanding any dispute or disputes raised by the Contractor(s) / Supplier(s) in any suit or proceedings pending before any court or Tribunal relating thereto our liability under this present being, absolute and unequivocal.

The payment so made by us under this Bond shall be a valid discharge of our liability for payment there under and the Contractor(s) / Supplier(s) shall have no claim against us for making such payment.

We, ..... Bank further agree that the Guarantee herein contained shall remain in full force and effect during the period that would be taken for the performance of the said Agreement and that it shall continue to be enforceable till all the dues of the RailTel under or by virtue of the said Agreement have been fully paid and

its claims satisfied or discharged or till RailTel certifies that the terms and conditions of the said Agreement have been fully and properly carried out by the said Contractor(s) and accordingly discharges this Guarantee. Unless a demand or claim under the Guarantee is made on us in writing on or before the ..... (Date of validity of BG). We shall be discharged from all liability under this Guarantee thereafter.

We,..... (indicate the name of Bank) Further agree with the RailTel that the RailTel shall have the fullest liberty without our consent and without affecting in any manner our obligations hereunder to vary any of the terms and conditions of the Agreement or to extend time of to postpone for any time or from time to time any of the powers exercisable by the RailTel against the said contractor(s) and to forbear or enforce any of the terms and conditions relating to the said Agreement and we shall not be relieved from our liability by reason of any such variation, or extension to the said Contractor(s) or for any forbearance, act or omission on the part of RailTel or any indulgence by the RailTel to the said Contractor(s) or by any such matter or thing whatsoever which under the law relating to sureties would, but for this provision, have affect of so relieving us.

This Guarantee will not be discharged due to the change in the Constitution of the Bank or the Contractor(s) Supplier(s).

We, the ..... Bank further agree that this guarantee shall be invocable at our place of business at ...../Kolkata (indicate detailed address of local Kolkata Branch with code no.). The branch at Kolkata is being advised accordingly.

We,.....(Indicate the name of Bank) lastly undertaken not to revoke this Guarantee during its currency except with the previous consent of the RailTel in writing.

Dated the ..... day of ..... 2026.

For.....

RailTel Corporation of India Ltd.  
(Indicate the name of the Bank)

**Witness:**

1. Signature  
Name
2. Signature  
Name

**OFFER LETTER**

**Form-III**

**(To be submitted separately for each tender/ section HQ)**

**From:**

**M/s.** \_\_\_\_\_

**To,**

**The Principal Executive Director,**

Eastern Region, RailTel Corporation of India Limited

19<sup>th</sup>Floor, Aurora Waterfront Building, 34/1, Block-GN, Sector-V,

Salt Lake City, Kolkata – 700 091

**Sub:** Deployment of maintenance team for maintenance of optic fibre cable network and upkeep of associated gears in Bhagalpur Section of RCIL/ER for a period of 2 years and extendable by one year on same terms and conditions.

**Ref: GeM Bid No. : GEM/2026/B/7389020, Dt. 25.03.2026**

I/We the undersigned hereby offer to execute the agreement for the above work within seven days from the date of issue of letter of acceptance of the tender in strict compliance within the provision detailed in the tender document attached.

I/We agree that this tender shall not be restricted or withdrawn and shall remain open for acceptance for and during the period of 120 days from the date of opening of the tender.

I/We fully understand the terms and conditions as contained in the tender document and we agree that the same shall apply to Our tender and I/We shall be bound by them.

Earnest money deposit @ 2% total tender value (as calculated in Clause 9) for respective tendered section drawn in favour of RailTel Corporation of India Ltd., payable at Kolkata is enclosed.

The full value of the earnest money shall be forfeited without prejudice to any other right or remedies if: -

I/We do not execute the contract document within 15 days after the receipt of notice by the RailTel Corporation that such documents are ready.

I/We do not commence work within 21 days from the date of issue of letter of acceptance.

Until a formal agreement is prepared and executed, acceptance of this offer letter shall constitute a binding contract between us subject to modification as may be mutually agreed to between us and indicated in the letter of acceptance of my/our offer.

I enclose herewith the following documents in support of my credential: -

1. Net Banking Reference No....., dated..... issued by..... for Rs..... (Rs.....only) as earnest money
2. Name and Qualification of supervisor, Technician and Splicer.

**List of the Equipments, Make, Model No. in working condition for each section of Works.**

Description	Make	Model No.	Year of purchase	Invoice No. (Copy of invoice should attached)	LDC (Last Date of Calibration)	Qty.
Vehicle (Innova/Qualis/UV)						
Portable Gen Set						
Lighting Arrangement						
Fusion Splicing Machine with 2 nos. of Cleavers						
Power Source						
Power Meter						
OTDR (min. range 200 Km.)						
OFC Cable Route Detector						
Spare Battery of splicing machine with Charger						
Cable Splitter						
Patch cord & Connectors						
Duct Cutter						
Road-O-meter						
Clamp type Earth Megger & AC/DC Meter						
Communication gadget: As required (Telephone, Cell phone, E-Mail etc.)						
Tools/Tackles Kit						
Blow lamp or Hot air-gun						
1 Km. Dummy Fiber Spool						
500 Mtr. Aerial OFC having 24/48 Fibers						
Minimum 50 Mtr. Duct						
Rexene/ Polythene & Umbrella cover etc						
Portable Vacuum Cleaner						
Aluminum Ladder						
GPS Tracking Devices						
Laptop PC with minimum Core-i3 or equivalent processor						

**3. No. of support staff, which will be kept for maintenance: .....**

**4. Vehicle details along with its Registration No: .....**

Shortcomings in the above, if any, will be made good and section wise full details shall be furnished for each section to be awarded, before award of the contract by RailTel.

Yours Sincerely,

**Seal & Signature of the Tenderer**

Place: -

Date: -

**Witnessed by: -**

1. Signature:  
Name:  
Address:

2. Signature: -  
Name: -  
Address:

**Proformas**

1. Splice loss / dB loss Vs Km in section
2. OTDR measurements
3. Power measurements
4. Patrolling reports
5. Attendance
6. Material check
7. Failure / rectification report (Form-A & B)
8. Availability of Essential equipments.
9. Maintenance contractor monthly performance (SOR-A)
10. Maintenance contractor Bill certificate (SOR-B)
11. Joint inspection report of Air-Conditioner
12. Air-Conditioner Breakdown report card
13. Air-Conditioner maintenance report card
14. Joint inspection report of D.G. Set
15. D. G. Set Breakdown report card
16. D.G. Set maintenance report card
17. List of periodical maintenance to be carried out for Engine, Alternator & Control panel.
18. Schedule of periodical maintenance of D.G. Set Engine.
19. Fiber summary report
20. Format for recording information on running of 15 KVA, D.G. Set
21. Proforma for providing uniform & safety guard to maintenance team members.

**Proforma-1 & 2 : Proforma for Splice loss/ dB loss vs KM & OTDR measurements in section:**

Section: .....

Date:

Fiber Length: .....

Fiber No.	Km	Loss (dB)	dB/Km	OTDR EVENTS ( For ascending order inter station wise)											
				Kms											
				Stn 1- Stn 2	Stn 2- Stn 3	Stn 3- Stn 4	Stn 4- Stn 5	Stn 5- Stn 6							
1															
2															
3															
4															
5															
6															
7															
8															
9															
10															
11															
12															
13															
14															
15															
16															
17															
18															
19															
20															
21															
22															
23															
24/48															

**Signature of RailTel  
Engineer**

**Signature of Contractor  
with seal**

**PROFORMA 1 FOR MEASUREMENTS ----- A -> B**

**PROFORMA 2 FOR MEASUREMENTS ----- B -> A**

**Shall be submitted within 10 days of doing the measurements.**

**Proforma- 3 Proforma for Power Measurement:**

**Section:**

**Date:**

**Fibre Length:**

Fiber No.	Fiber length	dB Loss		Average	dB/Km	Remarks
		A-> B	B-> A			
1						
2						
3						
4						
5						
6						
7						
8						
9						
10						
11						
12						
13						
14						
15						
16						
17						
18						
19						
20						
21						
22						
23						
24/48						

**Signature of RailTel  
Engineer**

**Signature of Contractor with seal**

**Proforma-4 for Patrolling Reports:**

**Section:**

**For the month of:** \_\_\_\_\_

Sl. No.	Date	Name of Patroller	Section		Patrolled		Remarks	Signature
			From	To	From	To		
			Station (Km.)	Station (Km.)	(Km.)	(Km.)		

**Signature of RailTel Engineer**

**Signature of Contractor with seal**



RailTel Corporation of India Ltd.

(A Minor and Category - I Enterprise)





**Proforma for OFC Failure / Rectification Report:**

Section:

Date:

 Failure/ Rectification:

Sl.	Description	Details
1	Name of the station &/or Pole No. of the Fault and Optical distance from nearest RailTel /Railway node.	
2	Date & Time of receiving information about the failure (Name & Designation of informer).	
3	Time of Departure of the Team from head quarter.	
4	Time of testing by OTDR to localize the fault	
5	Station from where OTDR test has been done	
6	Time of reaching to the location of fault.	
7	Time of restoration of the fault.	
8	Details of reasoning for the occurrence of the fault.	
9	i) Depth of Cable at Cut Location ii) Whether in Duct or Bare laid iii) Whether Brick protection in the block section of cut	
10	Type of restoration	Temporary / Permanent
11	If restoration is temporary give reason for temporary restoration.	
12	Reason for delay in restoration, for which contractor is not responsible (please give detailed break up of time). Separate sheet may be attached if required.	
13	Details of Rectification	
A	Period of block allowed	
B	Actual block period	
C	Reason for extension of block	

Signature of Engineer at site.

Signature of Contractor representative  
at site

Name:

Name:

Contd/...

14	Reason for rectification / block.	
A	Fibre swapped earlier (high loss / break)	Yes / No
B	Rectify partial cut	Yes / No
C	Rectify Ant attack in existing joint closure	Yes / No
D	For permanent restoration (earlier temporary rectification was done)	Yes / No
E	Date of temporary rectification, if any	
F	Date on which the failure could be identified.	
G	Length of OFC used for restoration of failure.	
15	Details about ground work	
A	Length of excavation & refilling of trench.	
B	Depth of trench (should be 1.2 metre), if desired depth can not be achieved, give details of protection provided.	
C	No. of Joint closure used.	1 / 2 / Existing Joint Closure
Details about Joint Closure at Pit – 1		
D	Length of OFC of interruption cable kept in the joint pit – 1	
E	Length of OFC of main cable kept in the joint pit – 1	
F	Whether sealing of joint closure has been done properly	Yes / No
G	Depth of closure at pit – 1 from ground level (it should be 1.2 metre)	
H	Location of Joint closure / pit – 1 (give pole No. & offset from centre of nearest track <b>along with Longitude &amp; Latitude</b> )	
I	Whether the cable route plan has been modified and location of Joint closure has been indicated in the existing cable route plan.	Yes / No
Details about Joint Closure at Pit – 2		
J	Length of OFC of interruption cable kept in the joint pit – 2	

Signature of Engineer.

Signature of Contractor representative

Name:

Name:

Contd/....

	Length of OFC of main cable kept in the joint pit – 2	
L	Whether sealing of joint closure has been done properly	Yes / No
M	Depth of closure at pit – 2 from ground level (it should be 1.2 metre)	
N	Location of Joint closure / pit – 2 (give pole No. & offset from Centre of nearest track <b>along with Longitude &amp; Latitude</b> )	
O	Whether the cable route plan has been modified and location of Joint closure has been indicated in the existing cable route plan.	Yes / No
15	Item used during restoration / protection	
A	RCC/FRP	
B	HDPE	
C	G.I Pipes	
D	Joint chamber	
D	Joint marker	
E	Sand filling in Joint Chamber – 1	
F	Sand filling in Joint Chamber – 2	
G	Concreting (width 30 cms, thickness 15 cms)	
H	Any other items	
16	Remark of the Team in Charge of the Section.	
17	Remark of the RailTel Representative at site.	

Signature of Contractor with seal

Signature of Engineer

Name:

Designation:

**Availability of Essential Equipment**

Sr. No.	Essential Equipment	Workability	Availability for the whole period	Non availability / Non workability with period
1	Team Vehicle	Working/Not working	Yes / No	From ..... To.....
2	Portable Gen Set	Working/Not working	Yes / No	From ..... To.....
3	Lighting Arrangement	Working/Not working	Yes / No	From ..... To.....
4	Fusion Splicing Machine with 2 nos. of Cleavers	Working/Not working	Yes / No	From ..... To.....
5	Power Source	Working/Not working	Yes / No	From ..... To.....
6	Power Meter	Working/Not working	Yes / No	From ..... To.....
7	OTDR (min. range 200 Km.)	Working/Not working	Yes / No	From ..... To.....
8	OFC Cable Route Detector	Working/Not working	Yes / No	From ..... To.....
9	Spare Battery of splicing machine with Charger	Working/Not working	Yes / No	From ..... To.....
10	Cable Splitter	Working/Not working	Yes / No	From ..... To.....
11	Patch cord & Connectors	Working/Not working	Yes / No	From ..... To.....
12	Duct Cutter	Working/Not working	Yes / No	From ..... To.....
13	Road-O-meter	Working/Not working	Yes / No	From ..... To.....
14	Clamp type Earth Megger	Working/Not working	Yes / No	From ..... To.....
15	Clamp type AC/DC MultiMeter	Working/Not working	Yes / No	From ..... To.....
16	Communication gadget	Working/Not working	Yes / No	From ..... To.....
17	Tools/Tackles Kit	Working/Not working	Yes / No	From ..... To.....
18	Blow lamp or Hot air-gun	Working/Not working	Yes / No	From ..... To.....
19	1 Km. Dummy Fiber Spool	Working/Not working	Yes / No	From ..... To.....
20	500 Mtr. Aerial OFC having 24/48 Fibers	Working/Not working	Yes / No	From ..... To.....
21	Minimum 50 Mtr. Duct	Working/Not working	Yes / No	From ..... To.....
22	Rexene/ Polythene & Umbrella cover etc	Working/Not working	Yes / No	From ..... To.....
23	Portable Vacuum Cleaner	Working/Not working	Yes / No	From ..... To.....
24	Aluminum Ladder	Working/Not working	Yes / No	From ..... To.....
25	Minimum 2 No. of Jointing Pit	Working/Not working	Yes / No	From ..... To.....
26	GPS Tracking Devices	Working/Not working	Yes / No	From ..... To.....
27	Laptop PC with minimum Core-i3 or equivalent processor	Working/Not working	Yes / No	From ..... To.....

- Strike out which is not applicable

Signature of RailTel Engineer

Signature of Contractor with seal

Proforma-9

**MAINTENANCE CONTRACTOR MONTHLY PERFORMANCE (SOR-A)**

Maintenance Section:		Headquarter:								
LOA/CA Valid up to:		Certificate for the Month of:								
Name of the Contractor:										
LOA/CA NO. & Date:										
OFC RKM:	NO of Acs in the Section:	Window Type:	Split Type:	No. of DG sets in the Section:						
WHETHER REQUIRED MINIMUM MANPOWER, VEHICLE,EQUIPMENTS AVAILABLE DURING THE BILLING PERIOD? (Yes/No):										
If "No", then furnish details of what was not available (give period of non availability):										
(i) .....non availability period: from.....To.....Days.....										
FOUR MONTHLY (QUADRIMESTRE) OTDR TEST REPORT DUE ON (DATE):	WHETHER SUBMITTED(Yes/No):		DATE OF SUBMISSION OF OTDR REPORT:							
Reconciliation statement for materials issued by RCIL has been received & ok (Yes / No):										
<u>Deateils of SOR-B Work Orders:</u>										
SL NO. SOR "B"WORK ORDER NO & DATEWORK STATUS PENALTY (Yes/No):										
Whether AC, DG sets, Voltage Stabilizers, Auto Sequencers, Shelters, Power plant, Wi-Fi systems in the sections have been maintained as per tender condition? (Yes / No) (If – NO: give details in separate sheet/reverse of the certificate)										
Whether any pending works prevailing against current & previous period in the section? (YES/NO): (If "YES" then give the details in Annexure-G (Proforma 9A: For Pending Works) & attach with this certificate)										
Bicycle/Foot Patrolling	Sub-sections where patrolling not complied thrice/month		Sub-Section Name	No. of Times						
Train Patrolling	Sections where patrolling not complied thrice/week		Section Name	No. of Times						
NO. OF FAILURES DURING THE BILLING PERIOD & DETAILS,CERTIFICATE THERE OF:										
S N	Date	Block Section	Locati on (offset )	From (Hrs.)	To (Hrs.)	Duration (Hrs.)	Proper sealing, Jt Pit, Marker, Sand filling done as per requirements (Yes/No): If "No", Then which work was not done	Whe r all fiber ok after rectific ation (Yes/N o):	As- built Dra wing upda ted (Yes /N	Temp orary/ Perma nent
1										

2									
3									

Note: (i) Attach the form 7'A' for all failures. Ensure that no cells of the form are left blank.

- (ii) For any additional information with regard to the maintenance period, please use the reverse of this certificate and/or use additional sheet.
- (iii) All over writing etc. are to be countersigned by the user of the certificate.,
- (iv) For any failure duration for which “force majeure” clause is applicable separate recommendations with justifications for waiver may be attached with this certificate.
- (ii) A copy of certificate is to be handed over to the contractor.
- (vi) The certificate should be issued every month and should reach R.O by the 15<sup>th</sup> of the following month.

List of enclosures:

(Signature, Date & Stamp of the Engineer)

SM/CM/AGM/DGM/Sr. DGM/JGM/TM

रेलटेल  
RAILTEL

RailTel Corporation of India Ltd.

(A Major and Category 1 Enterprise)

**Annexure-G (For Pending Works)**

<b>Sr. No.</b>	<b>Date of Failure</b>	<b>Date of Permanent Restoration</b>	<b>Period of Temp. condition</b>	<b>Section (Location) of Failure</b>	<b>Items Pending for Permanent Restoration</b>	<b>Status of Failure</b>	<b>Reason for Pending Works</b>



रेलटेल  
RAILTEL

RailTel Corporation of India Ltd.

(A Multinational Category - 1 Enterprise)

**Proforma-10**  
**MAINTENANCE CONTRACTOR BILL CERTIFICATION (SOR B)**

MAINT. SEC:					HQ:		
PERIOD OF BILL :							
NAME OF THE CONTRACTOR :							
BILL NO. & DATE ;							
LOA/CA NO & DATE :					LOA/CA PERIOD :		
BILL RECEIVED ON :				BILL CERTIFIED & SENT TO R.O.ON:			
REASON WHY 'SOR-B' WORK WAS NECESSITATED (Attach separate sheet if necessary) :							
CERTIFICATE OF WORK DONE:							
Sl No	Short description of the work done	SOR B Sch ref. of the item	Unit	Unit rate as per SOR-B (Rs.)	Qty claimed by the Contractor	Actual Qty executed	Certification of quality of work done by the Contractor
1							
2							

- NOTE: (i) For any additional information with regard to the bill, please use the reverse of this certificate.
- (ii) All over-writing etc. are to be countersigned by the issuer of the certificate.
- (iii) Attach copy of the measurement certificate which was issued immediately after completion of the work.
- (iv) A copy of this certificate is to be handed over to the Contractor (for raising bill).
- (v) Attach contractor's bill and other forms in connections with the work done.
- (vi) The certificate with all enclosures (including bill of contractor) should be sent to R.O within 10 days from the date of receipt of the bill.

List of enclosures:

(Signature, Date & Stamp of the  
Engineer of the section)

SM/AGM/DGM/JGM/TM

**Joint Inspection Report of Air Conditioner**

Station:

SI No	Defect noticed / services required	Air Conditioner			
		No. - 1	No. - 2	No. - 3	No. - 4
1	Compressor defective	Yes / No	Yes / No	Yes / No	Yes / No
2	Require Gas Charging	Yes / No	Yes / No	Yes / No	Yes / No
3	Steiner Capillary defective	Yes / No	Yes / No	Yes / No	Yes / No
4	Running Capacitor defective	Yes / No	Yes / No	Yes / No	Yes / No
5	Starting Capacitor defective	Yes / No	Yes / No	Yes / No	Yes / No
6	Motor Capacitor defective	Yes / No	Yes / No	Yes / No	Yes / No
7	Front Grill defective	Yes / No	Yes / No	Yes / No	Yes / No
8	Relay defective	Yes / No	Yes / No	Yes / No	Yes / No
9	Fan Motor defective	Yes / No	Yes / No	Yes / No	Yes / No
10	Blower Fan defective	Yes / No	Yes / No	Yes / No	Yes / No
11	Stabilizer 5 kva defective	Yes / No	Yes / No	Yes / No	Yes / No
12	Change over unit (timer) defective				
<b>Other defects (if any)</b>					
13					
14					
15					
16					
17	Working properly with effective cooling				

Signature of Engineer:

Signature of Contractor's Representative:

Designation:

Designation:

Name:

Name

Date:

Date:

**Proforma-12**

**AC - 2**

**Air Conditioner Breakdown Report Card**

**Number of Air Conditioner Installed: 1 / 2 / 3 / 4**  
 (Strikeout whichever is not applicable)

**Station:**

Machine No	Machine Failed on		Machine Repaired on		Failure duration (hrs)	Status after repairing	Signature representative of	
	Date	Time	Date	Time		Working /Not working	Engineer	Contractor

Signature of Engineer:

Signature of Contractor's Representative:

Designation:

Designation:

Name:

Name

Date:

Date

**Proforma-13****AC - 3****Air Conditioner Servicing Report Card****Number of Air Conditioner Installed: 1 / 2 / 3 / 4**

(strike out whichever is not applicable)

**Station:****Servicing of each machine: To be done once in three months**

Description of machine & details of servicing		Servicing		Status	Signature of	
		Due date	Done on	Working / Not working	Engineer	Contractor representative
Machine No. - 1	Servicing - 1					
	Servicing - 2					
	Servicing - 3					
	Servicing - 4					
Machine No. - 2	Servicing - 1					
	Servicing - 2					
	Servicing - 3					
	Servicing - 4					
Machine No. - 3	Servicing - 1					
	Servicing - 2					
	Servicing - 3					
	Servicing - 4					
Machine No. - 4	Servicing - 1					
	Servicing - 2					
	Servicing - 3					
	Servicing - 4					

Signature of Engineer:

Signature of Contractor's Representative:

Designation:

Designation:

Name:

Name:

Date:

Date:

**Joint Inspection Report of DG Set**

Station:

Sr. No.	Defect noticed / services required	Status
1	DG Set fails to start	Yes / No
2	Alternator is not giving output voltage	Yes / No
3	Alternator output voltage is fluctuating	Yes / No
4	Alternator is not delivering load	Yes / No
5	Frequency of output voltage is out of range	Yes / No
6	Multi Display meter is not working	Yes / No
7	AMF panel of DG Set is not working	Yes / No
8	DG Set, Battery charger is not working	Yes / No
9	Input Contactor coil is defective	Yes / No
10	Output Contactor coil is defective	Yes / No
11	Battery is not taking load during start	Yes / No
12	Exhaust Fan is not working	Yes / No
<b>Other defects (if any)</b>		
12		
13		
14		
15		
16	Working properly with effectively delivering the load	

Signature of RailTel Engineer

Signature of Contractor's Representative:

Designation:

Designation:

Name:

Name

Date:

Date:

**Diesel Generator Set Breakdown Report Card**

(Strike out whichever is not applicable)

Sr. No.	DG Set Failed on		DG Set Repaired on		Failure duration (hrs)	Status after repairing	Signature representative of	
	Date	Time	Date	Time		Working / Not working	RailTel	Contractor

Signature of Engineer:

Signature of Contractor's Representative:

Designation:

Designation:

Name:

Name

Date:

Date

**Proforma-16****DG - 3****Diesel Generator Set Servicing Report Card**

(strike out whichever is not applicable)

**Station:**

Table - 1

Activities	After Every 3 months							
	Qtr - 1		Qtr - 2		Qtr - 3		Qtr - 4	
	Due date	Done on	Due date	Done on	Due date	Done on	Due date	Done on
Drain out sump oil from Engine.								
Fill the fresh Engine Oil 20 W 40.								
Replace Oil Filter Assembly/Element.								
Drain out water droplets from fuel filter bowl by Drain screw (see note - 1 below).								
Clean the fuel feed pump bowl and it's Filter.								
Clean the Air cleaner Primary Filter by just blowing air from inside to outside.								
Clean Air Cleaner filter housing by dry cloth.								
Adjust tappet clearance of the both valve as per specified Value.								
Clean the Breather Assembly.								
Take out primary Fuel Filter Element & Dispose off.								
Take out Secondary Fuel Filter Element & Fit in primary Filter Pot.								
Replace in secondary pot new Fuel Filter Element.								
Check V-Belt condition & if need Adjust it.								
Checking & Tightening of Pedestal Mounting Nut Bolts.								

Activities	After Every 3 months							
	Qtr- 1		Qtr - 2		Qtr - 3		Qtr - 4	
	Due date	Done on	Due date	Done on	Due date	Done on	Due date	Done on
Check electrolyte level in each Battery cell, if need top up.								
Clean the Battery terminals and smears them with petroleum jelly.								

**Table – 2**

Activities	After every 12 months		After every 18 months	
	Due date	Done on	Due date	Done on
Replace Air Cleaner primary Filter or earlier (see note - 2 below)				
Check Injectors pressure, spray pattern & Dribbling at Authorized Service Centre.				

Note:

1. According to environmental conditions, drain the water from fuel filter assembly by loosing the drain screw at the bottom of fuel filter. If humidity is more, then drain after every 15 days.
2. The filter choking time depends on user's environmental conditions, normal life of filter element is approximate 1000 hours. If choke indicator indicates choking before 250 hours or its choking frequency trend is increasing, then replace the new primary filter element.

Signature of Engineer:

Signature of Contractor's Representative:

Designation:

Designation:

Name:

Name

**List of Periodical Upkeep to be carried out for  
“Engine, Alternator & Control Panel”.**

**Monthly:**

1. Check Diesel level in fuel tank and record
2. To check for leakage of Oil & Diesel in the D.G Set.
3. Drain out sump oil from Engine.
4. Fill the fresh Engine Oil 20 W 40.
5. Drain out water droplets from fuel filter bowl.
6. Clean the Air cleaner Primary Filter by just blowing air from inside to outside.
7. Clean the fuel feed pump bowl and it's Filter.
8. Clean Air Cleaner filter housing by dry cloth.
9. Clean the Breather Assembly.
10. To check tightness of Mechanical Components in the Engine.
11. Tighten all Bolts & Nuts in the coupling of the D.G Set.
12. Adjust tappet clearance of the both valve.
13. Check Battery voltage.
14. Check the Battery Charging Circuit in the panel.
15. Check specific gravity & level of Battery electrolyte, if needed top up.
16. Clean the Battery terminals and smears them with petroleum jelly.
17. Check the Healthiness of Electronic Panel & its Operation.
18. Check Healthiness of Mechanical Safeties in Engine & Electrical Safeties in Panel.
19. Check and monitor all mechanical readings from Gauges.
20. Check the Terminal connections inside the Alternator Terminal Box.
21. Check automatic switching on & off of cooling fan.
22. Check tightness of all connections in the terminals.
23. Check V-Belt condition & if need Adjust it.
24. Replace Oil Filter Assembly/Element.

**Bi-monthly:**

Carry out all types of Maintenance as per Monthly Visit.

1. Take out primary Fuel Filter Element & Dispose off.
2. Take out Secondary Fuel Filter Element & Fit in primary Filter Pot.
3. Replace in secondary pot new Fuel Filter Element.
4. Check oil level in the sump by Dipstick mark.

**Quarterly:**

1. All the Maintenance as per Monthly Visit.
2. Carry out cleaning of Air Filter, AVR Connections etc.
3. Check for coupling healthiness.

**Annual:**

1. Carry out all monthly checks.
2. Replace Air Cleaner primary Filter.

**One and half yearly:**

1. Carry out all monthly checks.
2. Check Injectors pressure, spray pattern & Dribbling from a Authorized Service Centre

**Schedule of Periodical upkeep of DG Set Engine  
(Recommended by Manufacturer):**

<b>Category</b>	<b>Periodicity</b>
A	Activities on monthly basis
B	Activities on Bi-monthly basis
C	Activities on quarterly basis
D	Activities on Annual basis
E	Activities on one and half basis

<b>Activities</b>	<b>A</b>	<b>B</b>	<b>C</b>	<b>D</b>	<b>E</b>
Check Diesel level in fuel tank and record	•	•	•	•	•
Check oil Diesel leakage and diesel in the D G Set.	•	•	•	•	•
Drain out sump oil from Engine.	•	•	•	•	•
Fill the fresh Engine Oil 20 W 40.	•	•	•	•	•
Drain out water droplets from fuel filter bowl.	•	•	•	•	•
Clean the Air cleaner Primary Filter by just blowing air from inside to outside.	•	•	•	•	•
Clean the fuel feed pump bowl and it's Filter.	•	•	•	•	•
Clean Air Cleaner filter housing by dry cloth.	•	•	•	•	•
Clean the Breather Assembly.	•	•	•	•	•
To check tightness of Mechanical Components in the Engine	•	•	•	•	•
Tighten all Bolts & Nuts in the coupling of the D.G Set.	•	•	•	•	•
Adjust tappet clearance of the both valve as per specified Value.	•	•	•	•	•
Check Battery voltage.	•	•	•	•	•
Check the Battery Charging Circuit in the panel.	•	•	•	•	•
Check electrolyte level in each Battery cell, if need top up.	•	•	•	•	•
Clean the Battery terminals and smears them with petroleum jelly.	•	•	•	•	•
Check the Healthiness of Electronic Panel & its Operation.	•	•	•	•	•
Check Healthiness of Mechanical Safeties in Engine & Electrical Safeties in Panel.	•	•	•	•	•
Check and monitor all mechanical readings from Gauges.	•	•	•	•	•

Check the Terminal connections inside the Alternator Terminal Box.	•	•	•	•	•
Check automatic switching on & off of cooling fan.	•	•	•	•	•
Check tightness of all connections in the terminals.	•	•	•	•	•
Check V-Belt condition & if need Adjust it.	•	•	•	•	•
Replace Oil Filter Assembly/Element.	•	•	•	•	•
Take out primary Fuel Filter Element & Dispose off.		•	•	•	•
Take out Secondary Fuel Filter Element & Fit in primary Filter Pot.		•	•	•	•
Replace in secondary pot new Fuel Filter Element.		•	•	•	•
Check oil level in the sump by Dipstick mark.		•	•	•	•
Carry out cleaning of Air Filter, AVR Connections etc.			•	•	•
Check for coupling healthiness.			•	•	•
Replace Air Cleaner primary Filter				•	
Check Injectors pressure, spray pattern & Dribbling a Authorized Service Centre.					•

**Note:**

1. Accordingly environmental conditions needs, drain the water from fuel filter assembly by loosening the drain screw at the bottom of fuel filter. If humidity is more than drain after every 15 days.
2. The filter choking time depends on user's environmental conditions, normal life of filter element is approximate 1000 hours. If choke indicator indicates choking before 250 hours or its choking frequency trend is increasing, then replace the new primary element.

Proforma-19

Fiber summary for the year.....

Section:.....

Optical Length:.....Km

Date of Measurement										
		I st four month of the year			2nd four month of the year			3 rd four month of the year		
Fibre No.	Fibre length/ deployment	Optical Length (km)	Loss (dB)	Av. Loss (dB/km)	Optical Length (km)	Loss (dB)	Av. Loss (dB/km)	Optical Length (km)	Loss (dB)	Av. Loss (dB/km)
1										
2										
3										
4										
5										
6										
7										
8										
9										
10										
11										
12										
13										
14										
15										
16										
17										
18										
19										
20										
21										
22										
23										
24/48										

Signature & Name of Engineer of the section

Date

## Proforma-20

Format for recording information on running of 5/7.5/15 KVA, D.G. Set installed at each location									
Information regarding running of D.G. Set and pouring of "Diesel Oil"									
Sr. No.	Date	Hour meter reading (Analog)	Hour meter reading (on MDM)	Reading of "Oil level indicator" before pouring Diesel Oil	Quantity of "Diesel Oil" poured (Litre)	Reading of "Oil level indicator" after pouring Diesel Oil	"Diesel Oil" poured by Maintenance team / RailTel representative	Signature of Maintenance Team representative, if, Diesel Oil is poured by Mntce team	Signature of RailTel representative
1									
2									
3									
4									
5									
6									
7									
8									
9									
10									

\* For test run, The RailTel Engineer will note Hour-meter reading at start, at stop & duration of run of D.G. set & jointly sign the report with contractor.

**Proforma- 21**

**Proforma for providing uniform & safety guard to maintenance team members:**

Sl No	Name	Designation	Uniform & fluorescent green safety jacket (with RailTel logo in both front and back) (Yes/No)	Provided on (Date)	Signature of team member

Signature of RailTel Engineer with seal

Signature of Contractor

**Verified By (RailTel Section in charge)**



RailTel Corporation of India Ltd.

(A Minorana Category - I Enterprise)

## Chapter-15

### BID DATA SHEET

RailTel website: <https://www.railtel.in>

e-Tendering portal <https://gem.gov.in>

The section consists of provisions that are specific to various clauses of Tender Document.

Reference	Description
GeM Bid No.	GEM/2026/B/7389020, Dt. 25.03.2026
Name of Work	Deployment of maintenance team for maintenance of optic fibre cable network and upkeep of associated gears like AC, DG, Stabilizer, Change over unit, Shelter and Wi-Fi Equipments in <b>Bhagalpur</b> Section of RCIL/ER for a period of 2 years and extendable by one year on same terms and conditions.
Tender Notice	<b>Address:</b> General Manager/Operations Eastern Region RailTel corporation of India Ltd. 19 <sup>th</sup> floor, Aurora waterfront, GN 34/1, Block- GN, Sector –V, Salt Lake, Bidhannagar, Kolkata-700091, West Bengal <b>Last date of submission of e-bids (Online):</b> 15.04.2026 up to 14:00 Hrs. <b>Date &amp; Time of opening of eTender (online):</b> 15.04.2026 at 14:30 Hrs.
Offer Validity	<b>Validity of offer</b> 120 days (One hundred & twenty days) From the date of opening of tender
Tender condition- clause para 3 of preamble	<b>Eligibility criteria</b> As per clause 3.1 for technical eligibility and clause 3.2 for financial capability
Tender condition – preamble para 9	<b>Submission of Earnest Money Deposit</b> As per para 9 of preamble
Tender Condition- Preamble para 21	<b>Performance bank guarantee-</b> As per para 21 of preamble
Tender condition- preamble para 22	<b>Security Deposit</b> Not Applicable
Form-III	Form for Offer Letter & Offer Sheet
Chapter 12	Instructions to Tenderers & General Conditions of Contract
Chapter 13	Special Conditions of Contract
Chapter 16	Drawings

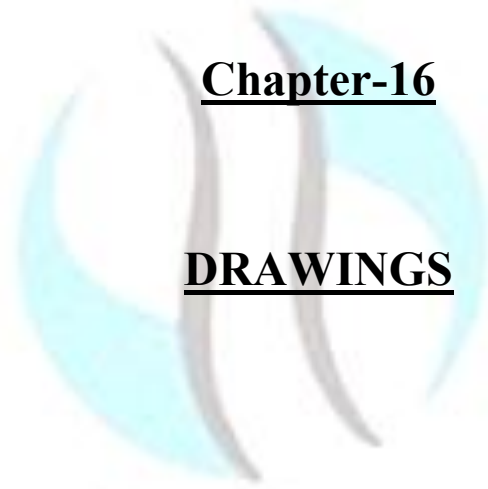

**Chapter-16**

**DRAWINGS**

रेलटेल  
RAILTEL

RailTel Corporation of India Ltd.

(A Mevratna Category - 1 Enterprise)

Annexure- 3.2

**RailTel Corporation of India Ltd., Eastern Region., Kolkata.**  
(Diagram of construction of Loop/Splice Chamber)

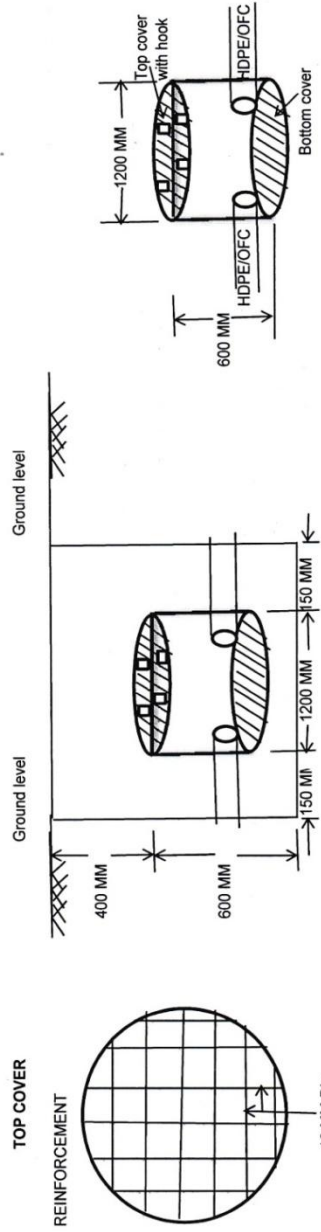

- 1 Pre Fabricated rings to be used for chambers .
- 2 65 mm Wall thickness
- 3 Reinforcement : 15 nos. of 8 mm steel rods vertical and 5 Rings of 6 mm steel Rod.
- 4 Chamber should be filled with river sand mixed with anti termite after placing the OFC inside.

Dr. No. RCIL/ER/DRG-02/06.

Proposed by <i>S. Navaguraj</i>	Approved by, <i>S. Navaguraj</i>
15.02.24	<i>S. Navaguraj</i>
	G.M.(C/P)

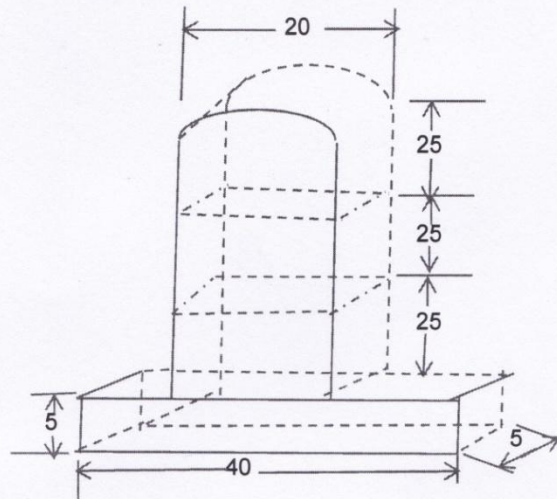
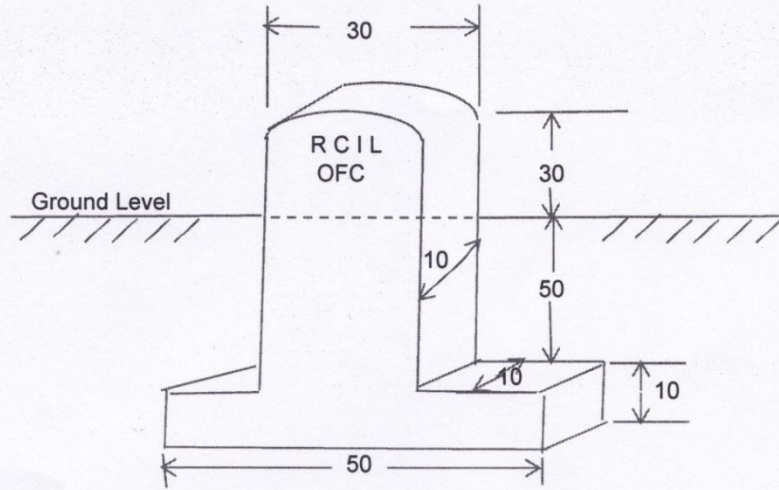

REINFORCEMENT 6 MM DIA

**NOTE :**

- 1 ALL DIMENSIONS ARE IN CM
- 2 ALL SIDES ABOVE GROUND TO BE PAINTED WITH RED ENAMELED PAINT TO IS SPECIFICATION WITH TWO COATS AT PLACES OTHER THAN OFC JOINTS.
- 3 ALL SIDES ABOVE GROUND TO BE PAINTED WITH GREEN ENAMELED PAINT TO IS SPECIFICATION WITH TWO COATS AT OFC JOINTS .
- 4 RCIL OFC TO BE ENGRAVED .
- 5 ENGRAVED PORTION TO BE PAINTED WITH WHITE ENAMELED PAINT TO IS SPECIFICATION WITH TWO COATS.

**RCC CABLE ROUTE MARKER**

NO. RCIL/ER/DRG-01/06

RAILTEL CORPORATION OF INDIA LTD.	DRAWN BY	CHECKED BY	APPROVED BY
EASTERN REGION	<i>[Signature]</i> Sr. Manager/BE M/EG	<i>[Signature]</i> 15-05-17	<i>[Signature]</i> 15-5-17
KOLKATA			<i>[Signature]</i> Am(EP)

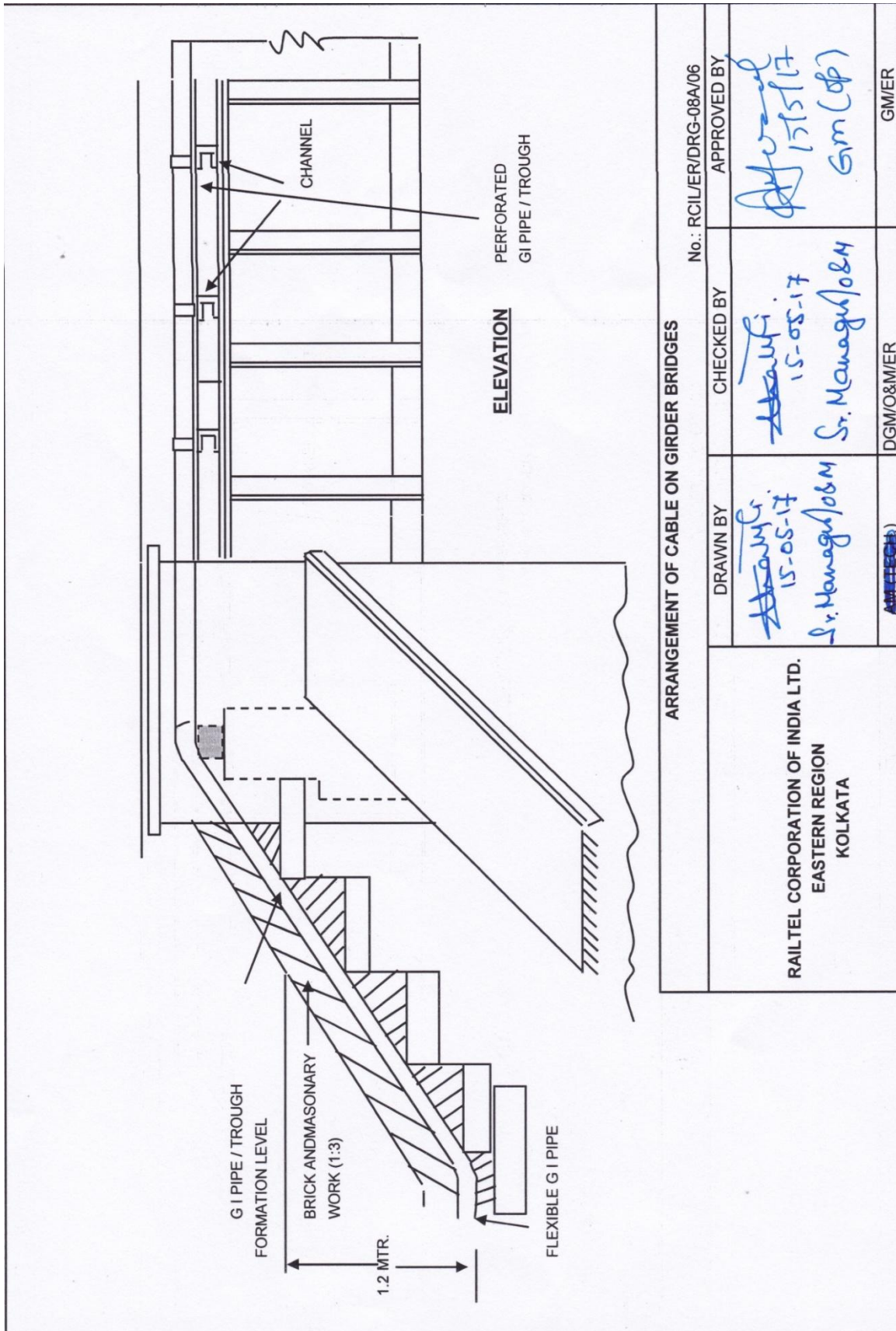

ARRANGEMENT OF CABLE ON GIRDER BRIDGES			
No.: RCIL/ER/DRG-08A/06		APPROVED BY	
DRAWN BY <i>Manjiv</i> 15-05-17 Sr. Manager/06M		CHECKED BY <i>Manjiv</i> 15-05-17 Sr. Manager/08M	
RAILTEL CORPORATION OF INDIA LTD. EASTERN REGION KOLKATA		DGM/O&M/ER	
<i>Manjiv</i>		<i>Gm (op)</i>	
GM/ER		GM/ER	

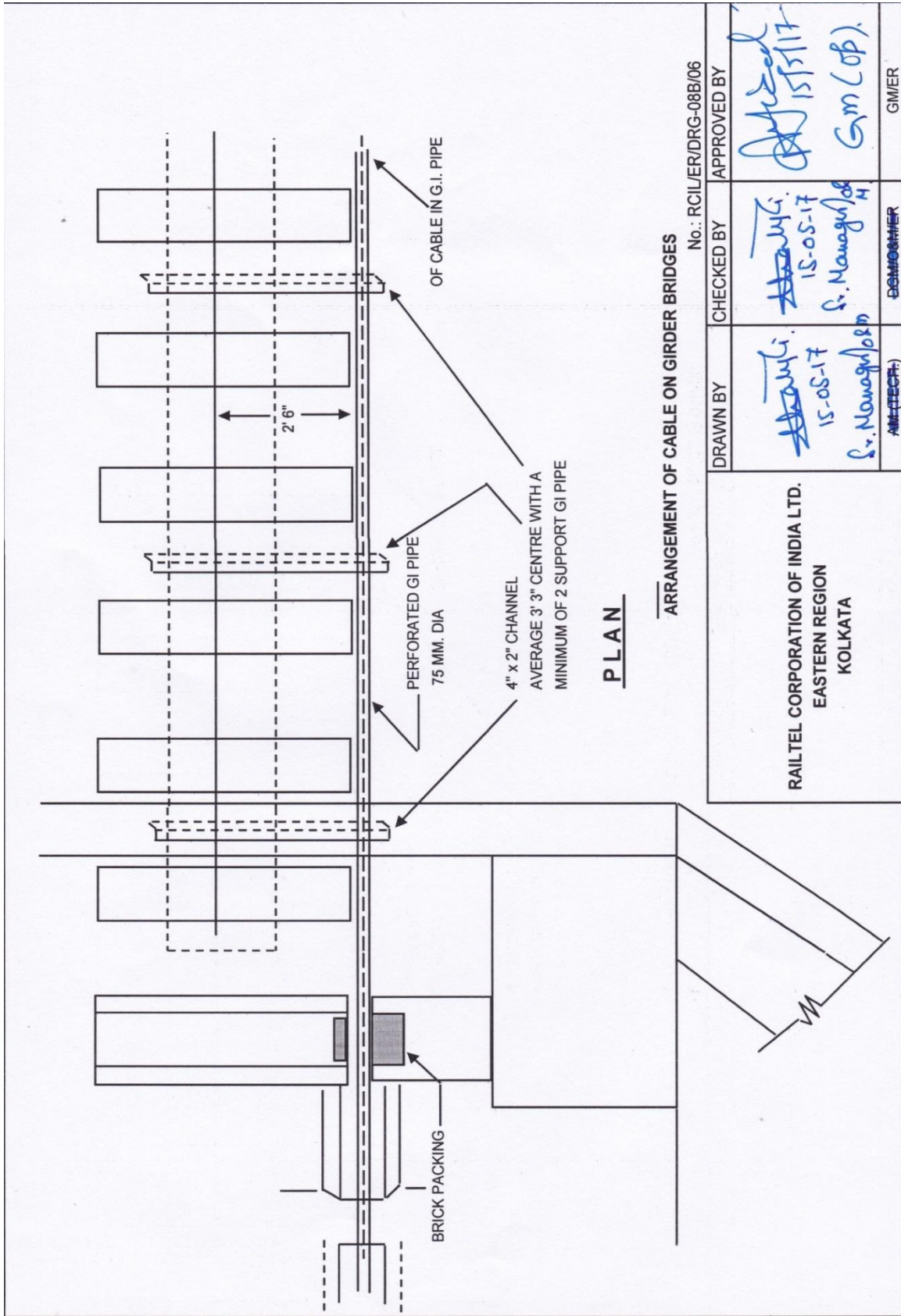

**PLAN**

ARRANGEMENT OF CABLE ON GIRDER BRIDGES

RAILTEL CORPORATION OF INDIA LTD. EASTERN REGION KOLKATA		No.: RCIL/ER/DRG-08B/06
DRAWN BY S. Manojkumar 15-05-17	CHECKED BY S. Manojkumar 15-05-17	APPROVED BY Gm (Op.)
AM/TECH/	DG/MS/MS/ER	GM/ER

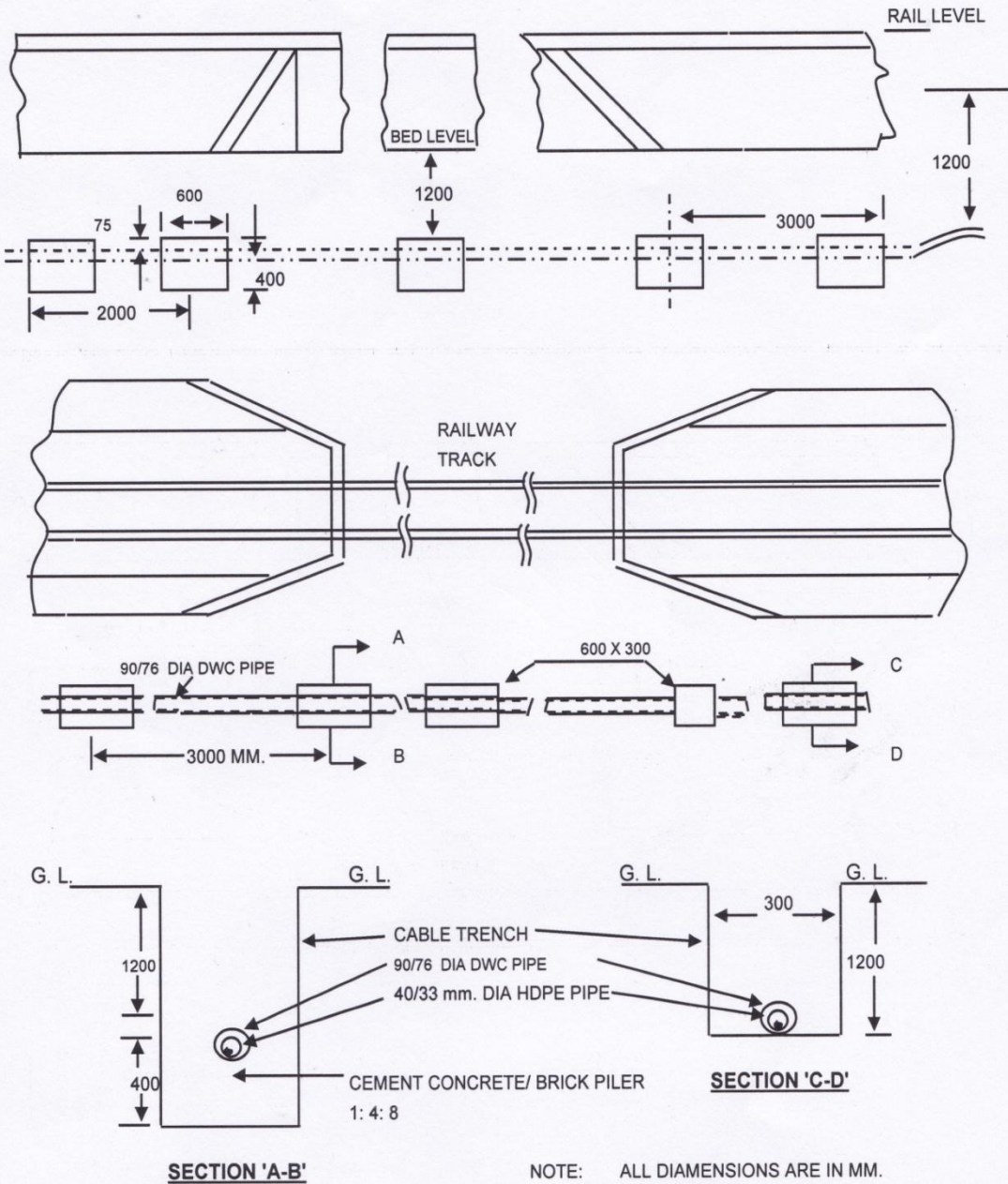

LAYING OF CABLE BELOW CULVERTS IN DWC PIPE

No.: RCIL/ER/DRG-06/06

	DRAWN BY	CHECKED BY	APPROVED BY
RAILTEL CORPORATION OF INDIA LTD. EASTERN REGION KOLKATA	<i>Shanku</i> 15-05-17 Sr. Manager/O&M	<i>Shanku</i> 15-05-17 Sr. Manager/O&M	<i>Shanku</i> 15/5/17 Gm(OF)

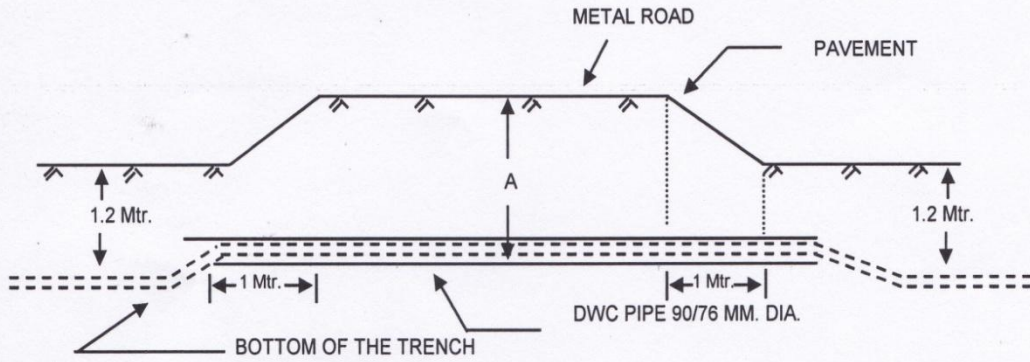

**NOTE:**

- 1 A = DEPTH WILL BE 1.2 MTR.  
OR  
AS DECIDED BY ENGINEER IN CHARGE  
AS PER SITE CONDITION.
- 2 LENGTH OF THE DWC PIPE SHALL EXTENDED BY  
1 MTR. BEYOND ROAD EDGES.

**ARRANGEMENT OF DWC PIPE TRUNKING UNDER METAL ROAD**

No.RCIL/ER/DRG-03/06

	DRAWN BY	CHECKED BY	APPROVED BY
RAILTEL CORPORATION OF INDIA LTD. EASTERN REGION KOLKATA	<i>[Signature]</i> 15-05-17 Sr. Manager/O&M	<i>[Signature]</i> 15-05-17 Sr. Manager/O&M/ ER	<i>[Signature]</i> 15/5/17

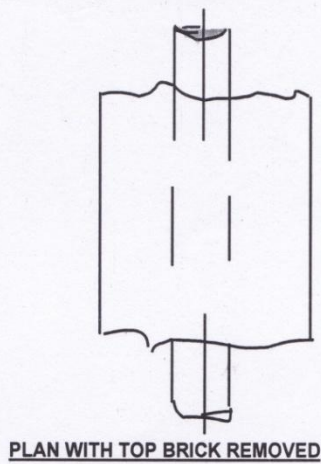
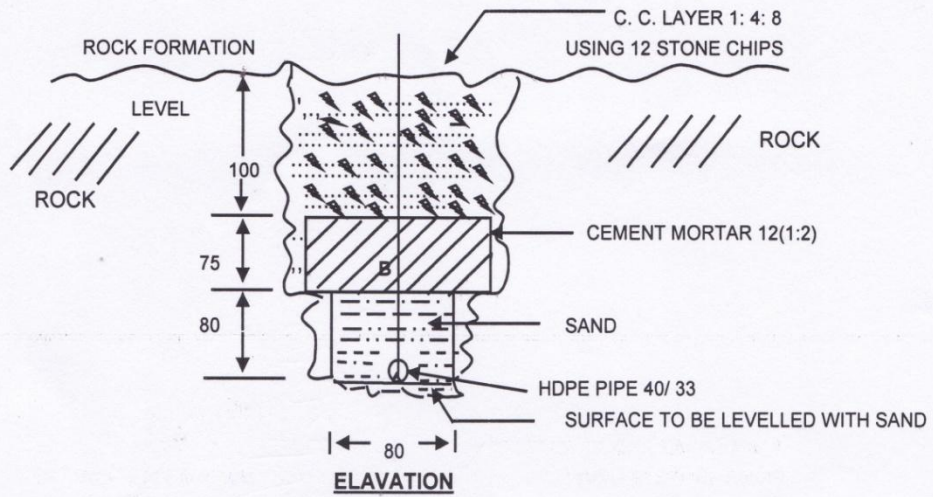

B : BRICK SECOND CLASS

NOTE :

- 1 BOTTOM OF THE CHANNEL SHALL BE FILLED WITH SAND TO LEVEL UNEVEN SURFACE.
- 2 SLOP SHALL BE SMOOTHLY SHAPED AND PLASTERED (1:3)
- 3 ALL DIMENSIONS ARE IN MM.

**CHASE CUTTING IN HARD ROCKY AREA**

No.: RCIL/ER/DRG-07/06

	DRAWN BY	CHECKED BY	APPROVED BY
RAILTEL CORPORATION OF INDIA LTD. EASTERN REGION KOLKATA	<i>[Signature]</i> 15-05-17 Sr. Manager/O&M	<i>[Signature]</i> 15-05-17 Sr. Manager/O&M	<i>[Signature]</i> Gm(Cop). 15/5/17

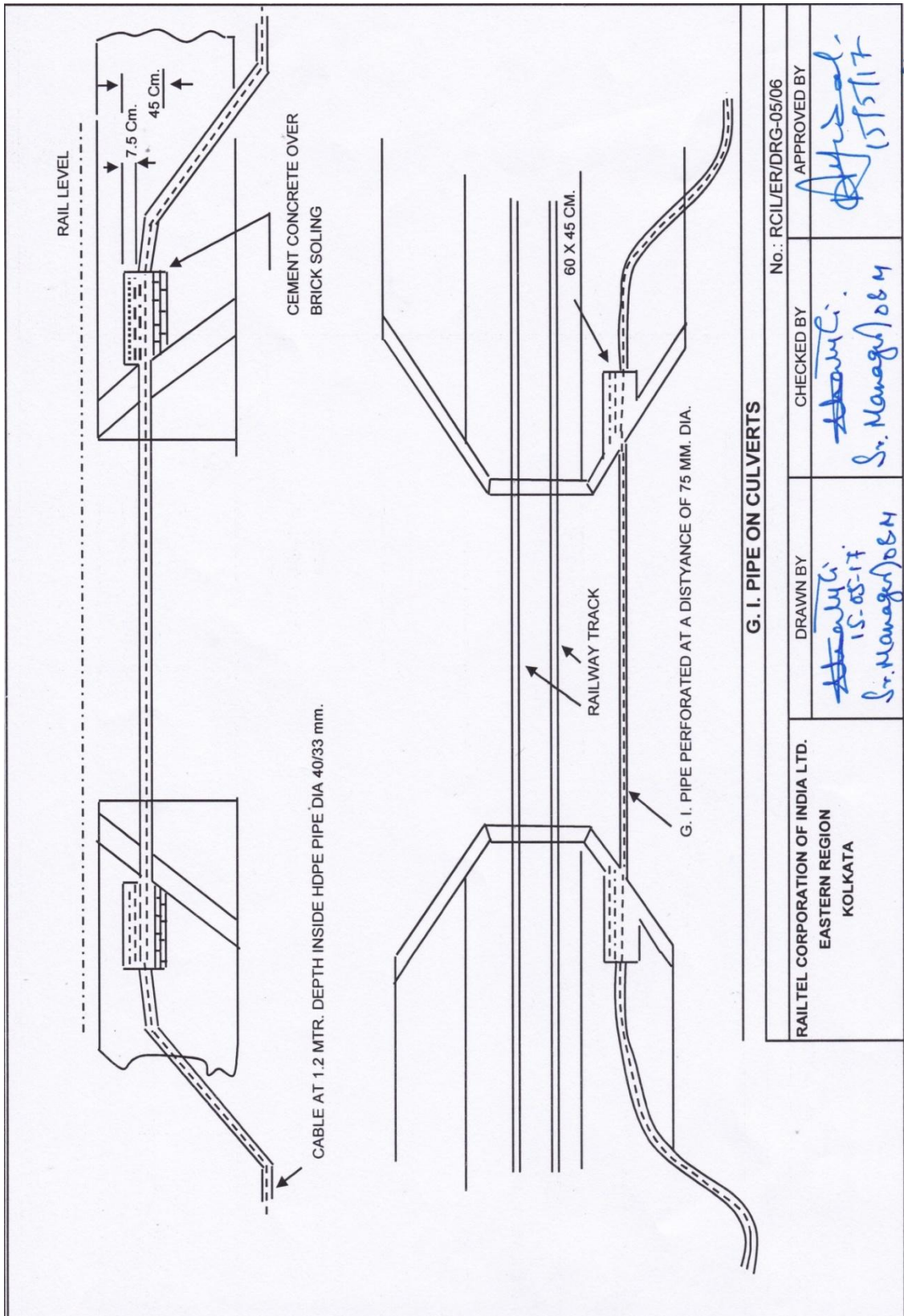

**G. I. PIPE ON CULVERTS**

RAILTEL CORPORATION OF INDIA LTD. EASTERN REGION KOLKATA	DRAWN BY <i>15-05-17</i> Sr. Manager/08M	CHECKED BY <i>15-05-17</i> Sr. Manager/08M	No.: RCIL/ER/DRG-05/06
	APPROVED BY <i>15/5/17</i> Sr. Manager/08M		

*2m/08M*