



RailTel Corporation of India Limited
6th Floor, Block-III, Delhi IT Park,
Shastri Park, Delhi-110053, Tel. No.: +91 (11) 22185933,
FAX: +91 (11) 22185978

रेलटेल कॉर्पोरेशन ऑफ इंडिया लिमिटेड
(भारत सरकार का एक उपक्रम)

RAILTEL CORPORATION OF INDIA LIMITED
(A Govt. of India Undertaking)
Invites open e-tender

ELECTRONIC TENDER DOCUMENT

FOR

Procurement, installation and commissioning of SMPS based Integrated Power Supply (IPS) for LC Gate in connection with "Upgradation of signalling from standard - I to standard - II R) with Electronic Interlocking (EI) at 4 stations in ASR-PTK of Firozpur division".

खुली-E-निविदा न. RCIL-SIG-IPS-17 Dt. 15.03.2024

OPEN E- Tender No. RCIL-SIG-IPS-17 Dt. 15.03.2024

Due for opening on: 05.04.2024

रेलटेल
RAILTEL



रेलटेल कॉर्पोरेशन ऑफ इंडिया लिमिटेड

6वां तल, ब्लॉक-III, दिल्ली आईटी पार्क, शास्त्री पार्क, दिल्ली-110053

टेलीफोन नंबर.: +91 (11) 22185933, फ़ैक्स: +91 (11) 22185978

E-TENDER No. RCIL-SIG-IPS-17 Dt. 15.03.2024

रेलटेल कॉर्पोरेशन ऑफ इंडिया लिमिटेड (रेलटेल), खुले e-निविदा में शामिल होने के लिए Procurement of SMPS based Integrated Power Supply (IPS) for LC Gate in connection with "Upgradation of signalling from standard - I to standard - II R) with Electronic Interlocking (EI) at 4 stations in ASR-PTK of Firozpur division". निविदा आमंत्रित करते हैं.

| | | |
|----|---|-----------------------------------|
| a) | E-निविदा downloading की शुरुआती तिथि | 15.03.2024 |
| b) | E-निविदा दस्तावेज प्रस्तुति अंतिम तारीख एवं समय | 05.04.2024, 15:00 बजे तक (Online) |
| c) | E-निविदा दस्तावेज को खोला जाना | 05.04.2024, 15:30 बजे (Online) |
| d) | अनुमानित निविदा की कीमत | Rs. 38,37,733/- |
| e) | धरोहर राशि (ईएमडी) # | Rs. 76,800/- (सब कुछ सम्मिलित) |
| f) | निविदा दस्तावेज की कीमत # | NIL |

योग्य MSEs को निविदा दस्तावेज और धरोहर राशि का मूल्य जमा कराने से छूट दी जाती है

नोट:- निविदा सूचना और निविदा दस्तावेज वेबसाइट www.railtelindia.com तथा e-Tendering Portal <https://www.ireps.gov.in> पर उपलब्ध रहेंगे जिसे निविदाकर्ता डाउनलोड कर सकते हैं लेकिन निविदा केवल इ-टेंडरिंग द्वारा e-Tendering portal <https://www.ireps.gov.in> पर ONLINE ही स्वीकार कि जाएंगी. निविदाकर्ता को E-निविदा जमा कराने के लिए <https://www.ireps.gov.in> से एक अधिकृत इ-दस्तावेज डाउनलोड करना आवश्यक है. Corrigendum /addendum /amendments सम्बंधित जानकारी केवल e-Tendering portal <https://www.ireps.gov.in> पर ही उपलब्ध होंगी. जाएगी। रेलटेल कार्यालय से निविदा प्रलेख की मुद्रित प्रति नहीं बेची जाएगी। बोलीदाता तैयारी, बोली की तैयारी/प्रस्तुति /भागीदारी से संबंधित सभी लागतों को वहन करेगा। रेलटेल किसी भी तरह से आचरण या परिणाम की उदासीनता से इन लागतों के लिए जिम्मेदार या उत्तरदायी नहीं होगा।

महाप्रबंधक/ रेलवे परियोजना



RailTel Corporation of India Limited
6th Floor, Block-III, Delhi IT Park, Shastri Park, Delhi-110053
Tel. No.: +91 (11) 22185933, FAX: +91 (11) 22185978

E-TENDER No. RCIL-SIG-IPS-17 Dt. 15.03.2024

RailTel Corporation of India Limited (RailTel), invites open e-tender for Procurement, installation and commissioning of SMPS based Integrated Power Supply (IPS) for LC Gate in connection with "Upgradation of signalling from standard - I to standard - II R) with Electronic Interlocking (EI) at 4 stations in ASR-PTK of Firozpur division".

| | | |
|----|--|--------------------------------------|
| a) | Opening date of Tender downloading | 15.03.2024 |
| b) | Last date and time of submission date of e-bid | 05.04.2024 up-to 15:00 hrs. (Online) |
| c) | Opening of e-bid | 05.04.2024 at 15:30 hrs. (Online) |
| d) | Approximate Cost of Tender | Rs. 38,37,733/- |
| e) | Earnest Money (EMD) # | Rs. 76,800/- (all incl.) |
| f) | Cost of Tender Document # | NIL |

Eligible MSEs are exempted from the cost of Tender Documents and EMD. No other exemption will be given.

Note: Tender Notice and Tender Document are available on RailTel's website and can be downloaded from www.railtelindia.com or from the **e-Tendering Portal** <https://www.ireps.gov.in>. For online bid submission the tenderer will have to necessarily download an official online copy of the tender documents from e-Tendering Portal <https://www.ireps.gov.in>. All future Information viz. corrigendum/ addendum/ amendments etc. for this Tender shall be posted on the e-Tendering Portal only. Printed copy of Tender document will not be sold from RailTel office. The bidder shall bear all costs associated with the preparation, submission/participation in the bid. RailTel in no way will be responsible or liable for these costs regardless of the conduct or outcome.

General Manager/ Railway Project

| <u>CONTENTS</u> | | <u>Page No.</u> |
|--------------------------------------|---|------------------------|
| Tender Document (Front Page) | | 1 |
| Tender Notice in Hindi & English | | 2-3 |
| Section I & Section II Index | | 4 |
| <u>SECTION 'I' (Variable)</u> | | |
| Chapter 1 | Schedule of Requirements (Price Schedule) | 5 |
| Chapter 2 | Bid Data Sheet | 6-7 |
| Chapter 2A | E-Tendering Instructions to Bidders | 8-10 |
| Chapter 3 | Special Tender Conditions | 11-12 |
| Chapter 4 | Technical Specifications. | 13 |
| <u>SECTION 'II' (Fixed)</u> | | |
| Chapter 5 | Offer Letter | 14 |
| Chapter 6 | Instructions to Tenderers. | 15-26 |
| Chapter 7 | General Tender Conditions | 27-32 |
| Chapter 8 | Standard Conditions of Contract | 33-58 |
| Chapter 9 | Annexure-I (Performa for Performance Bank Guarantee) | 59-60 |
| Chapter 10 | IPS Diagram | 61 |
| Chapter 11 | Check List | 62 |

(This tender document consists of 62 pages)

Chapter 1

Schedule of Requirements (SOR)

Schedule of Requirements is available on www.ireps.gov.in and rate should be quoted through IREPS portal only.

| SN | Items Description | Unit | Qty |
|---|--|------|-----|
| 1 | Supply, Installation, testing and Commissioning of SMPS based IPS conforming to RDSO Specn. No. RDSO/SPN/165/2012 Ver. 3.0 or latest amendment and sketch no SDO/IPS/LC/07 IPS for interlocked LC-Gate RE/NRE area along with 200AH LMLA battery bank (55+5) along with remote indication panel. The length of cables required from IPS to Battery bank 25 Sqmm flexible Copper Wire Red & black as per RDSO specification will be supplied by OEM. Sketch attached in document. (Inspection by RDSO). | Nos. | 4 |
| 2 | Inspection Charges @1% of Basic Rate | Nos. | 4 |
| Note: Locations for IPS installation are (1) Jaintipura LC Gate-17 (2) Batala LC Gate-23A (3) Dhariwal LC Gate-36 (4) Gurdaspur LC Gate-51 of FZR Division. | | | |

रेलटेल
RAILTEL

Chapter 2
BID DATA SHEET

| Reference | Description |
|---|---|
| Schedule of Requirement Chapter – 1 | <p>Name of work Procurement, installation and commissioning of SMPS based Integrated Power Supply (IPS) for LC Gate in connection with "Upgradation of signalling from standard - I to standard - II R) with Electronic Interlocking (EI) at 4 stations in ASR-PTK of Firozpur division".</p> |
| Tender notice | <p>Last date of submission (online) Date: 05.04.2024 Time: 15:00 Hrs.</p> <p>Date of opening of tender (online) Date: 05.04.2024 Time: 15:30 Hrs.</p> <p>Public Online Tender Opening Event (TOE) through e-Tendering portal of IREPS.</p> |
| Special Tender condition Clause – 3.3 Chapter 3 | <p>3.3 Eligibility/Qualification Criteria</p> <p>3.3.1 Technical Eligibility Criteria: The tenderer must have successfully completed any of the following during last 07 (seven) years, ending last day of month previous to the one in which tender is invited:</p> <ul style="list-style-type: none"> (i) Three similar works each costing not less than the amount equal to 30% of advertised value of the tender, or (ii) Two similar works each costing not less than the amount equal to 40% of advertised value of the tender, or (iii) One similar work each costing not less than the amount equal to 60% of advertised value of the tender. <p>3.3.2 Financial Eligibility Criteria: The tenderer must have received contractual payments in the previous three financial years and the current financial year up to the date of inviting of tender, at least 150% of the advertised value of the tender. The tenderers shall submit Certificates to this effect which may be an attested Certificate from the concerned department / client or Audited Balance Sheet duly certified by the Chartered Accountant/Certificate from Chartered Accountant duly supported by Audited Balance Sheet.</p> |

| | |
|---|--|
| | (Note: Client certificate from other than Govt. Organization should be duly supported by Form 16A/26AS generated through TRACES of Income Tax Department of India). |
| Instructions to Tenderers Clause – 6.4 Chapter 6 | Earnest money: Rs. 76,800/- (Rupees Seventy Six Thousand Eight Hundred only) through IREPS portal. |
| Instructions to Tenderers Clause – 6.15 Chapter 6 | Validity of offer: 60 days (Sixty days only) from the date of opening of tender. |
| Instructions to Tenderers Clause – 6.24 Chapter 6 | PVC clause: PVC clause is not applicable in this Tender. |
| Instructions to Tenderers Clause – 6.23.2 (1), Chapter 6 | Power of Attorney: Each and every page of bid & tender document should be marked with numerical numbers and signed by authorized representative of the firm. Power of attorney in favour of the signatory duly authorizing the signatory shall be enclosed in the bid. (Scanned copy to be uploaded on IREPS portal) |
| Special Tender condition Clause – 3.2, Chapter 3 | Delivery Period: Material is required to be delivered by the supplier to the consignee within 60 days of placement of Purchase Order. |
| General Tender condition Clause –6.5, Chapter 6 | Performance Bank Guarantee/ Security Deposit: Performance Bank Guarantee of 10% of total value of the Purchase Order is required to be submitted and should be valid for 15 months (12 +3)* from the date of issue Purchase Order. *12 months warranty and 3 months extra. |
| Special Tender condition Clause – 8.28, Chapter 8 | Warranty: The materials/items are to be warranted for a period of 12 months after the delivery at consignee end. |
| Special Tender condition Clause – 3.5 Chapter 3 | Bill passing: ED/RP or GM/RP Bill paying Authority: JGM/Finance/CO |
| Instructions to Tenderers Clause – 6.23.3 Chapter 6 | Authority & Address and Venue for Bid submission and opening Executive Director/RP, 6 th floor Tower- III, Delhi IT Park, Shastri Park, New Delhi-110053. |

Chapter - 2-A**E-tendering Instructions to Bidders****General**

These Special Instructions (for e-Tendering) supplement 'Instruction to Bidders', as enclosed in Chapter- 6 of the Tender Document.

Submission of Bids only through online process is mandatory for this Tender.

E-Tendering is a new methodology for conducting Public Procurement in a transparent and secured manner. Now, the Government of India has made e-tendering mandatory. Suppliers/ Vendors will be the biggest beneficiaries of this new system of procurement. For conducting electronic tendering, RailTel has decided to use the portal <https://www.ireps.gov.in> Indian Railways E-Procurement system (IREPS).

Benefits to Suppliers are outlined on the Home-page of the portal. Bidders are advised to visit the IREPS Portal for details related to E-Tender i.e. Registration, FAQ, Helpdesk, Learning Center etc.

1. Tender Bidding Methodology:

Sealed Bid System - 'Single Stage - Single Envelope': In this, bidder has to submit both Technical as well as Financial bid in single envelope "ONLINE."

IREPS Helpdesk

Please visit Helpdesk section on IREPS Portal.

RailTel Contact-1 (for general Information)

RailTel's Contact Officer
Sh. Ravi Manik Patil, GM/RP
Telephone/ Mobile: 9717630822
E-mail ID: raviirsse2010@railtelindia.com

RailTel Contact-II (for general Information)

RailTel's Contact officer
Sh. Jagdeep Singh, ED/RP
Telephone/ Mobile: 9779244100
E-mail ID: jagdeep@railtelindia.com

2. Bid related Information for this Tender (Sealed Bid)

The entire bid-submission would be online on IREPS Portal.

Broad outline of submissions are as follows:

1. Submission of Bid Security/ Earnest Money Deposit (EMD).
2. Submission of digitally signed copy of Tender Documents/Addenda.
3. Online response to Terms & Conditions of Tender.
4. (Optional) Online Submission of modification, substitution bids for technical or financial parts, or withdrawal bid.

NOTE: Bidder must ensure that the bid must be successfully submitted online as per instructions of IREPS Portal.

3. Online Submissions:

The bidder is required to submit all the relevant documents online only with the following documents.

- a) EMD submission **through IREPS portal.**
- b) Tender Cost submission, if any **through IREPS portal.**
- c) Power of attorney is to be uploaded online in accordance with Clause – 6.23.3, Chapter 6. Original copy is needed to be submitted by the bidder before due date & time.
- d) In case bidder happens to be an MSE bidder, the documentary evidence for same shall be submitted online.

4. Submission of Eligibility Criteria related documents

Eligibility criteria related documents as applicable shall also be scanned and submitted ONLINE

NOTE: In case of internet related problem at a bidder's end, especially during 'critical events' such as - a short period before bid-submission deadline, during online public tender opening event, during e-auction, it is the bidder's responsibility to have backup internet connections.

5. Instructions for Tender Document TO THE BIDDERS

The RailTel Tenders are published on www.railtelindia.com and on IREPS Portal <https://www.ireps.gov.in/>. In addition to submitting the e Tender documents online.

NOTE: For online bid submission the bidder will have to necessarily download an official online copy of the tender documents from IREPS portal, and this should be done well before the deadline for bid-submission.

6. Submission of Offers and Filling of Tender:

This e-tender should be duly submitted online using the e-Procurement Portal <https://www.ireps.gov.in/>. For detailed instructions please refer to IREPS Portal.

7. Fax Quotations & Late Tenders:

Fax Tender documents and Late/Delayed tenders would not be considered.

8. Attendance of Representatives for Tender Opening:

Representatives of bidders desirous to attend the tender opening can do so on production of a proper letter of authority from the respective firm, failing which they may not be allowed to attend the tender opening. Authorized representatives of those firms who have submitted the tender documents alone shall be allowed to attend the tender opening.

* * * * *



Chapter 3

SPECIAL TENDER CONDITIONS

3.1. The Tenderer shall quote Total all Inclusive Rate on C.I.P. destination basis clearly indicating the breakup of rates, applicable duties and taxes, etc. as detailed in the offer form on IREPS portal. Freight and Insurance charges have to be quoted for each state/UT of India.

3.2 (A) Delivery Period: -

- 1) Materials are required to be delivered by the supplier to the consignee within 60 days of placement of Purchase Order.
- 2) Consignee Address:
Sr. Manager/Technical/ASR, RailTel Corporation of India Ltd., Central Warehousing Corporation (CWC), Amritsar.
- 3) Material is required to be transported at site from CWC/ASR store for installation and commissioning.

3.2 (B) Installation, Commissioning and Testing: -

Installation, Commissioning and Testing covers supply of Tool Kit containing all type of tools required for maintenance of IPS set as per RDSO specification no. RDSO/SPN/165/2012 with latest amendment. The vendor shall submit IPS configuration with load calculation sheet and shall obtain RCIL engineer approval before supply. This includes Installation and commissioning of 55 no. LMLA Batteries of IRS: S-88/2004 as per extant practice of NRLY along with installation of Remote indication panel Gate goomty. Any masonry work, if required, will be carried out by contractor's own material. The 25 sq mm wire shall be used for connecting Batteries from IPS, 16 sq.mm Power cable is to be used for wiring of 110V DC & 110V AC and for 10 sq.mm power cable for rest of the supplies. All connectors, wiring material, ladders, DWC pipes etc as per site requirement are to be arranged by contractor as per instructions of RCIL engineer at site. The item includes transportation, loading and unloading of complete IPS system with Batteries from store to site of installation. All wiring will be done by using flexible multi strand copper wires of suitable size as recommended by RDSO in IPS's pre commissioning checklist. This includes extending various power supplies up to bus bars in Relay room/Location boxes and upto Battery room.

NOTE:- IPS will be installed ,wired ,tested and commissioned by OEMS's engineer as per guidelines issued by RDSO. The pre-commissioning checklist issued by RDSO for IPS will be prepared by OEM's engineer and signed jointly with site engineer. Before commissioning of IPS, OEM will submit site installation certificate by mentioning that IPS has been installed wired, tested and commissioned by approved vendor of RDSO i.e by OEM.

3.3 Eligibility/ Qualification Criteria:

3.3.1 Technical Eligibility Criteria:

The tenderer must have successfully completed any of the following during last 07 (seven) years, ending last day of month previous to the one in which tender is invited:

- (i) Three similar works each costing not less than the amount equal to 30% of advertised value of the tender, or
- (ii) Two similar works each costing not less than the amount equal to 40% of advertised value of the tender, or
- (iii) One similar work each costing not less than the amount equal to 60% of advertised value of the tender.

3.3.2 Financial Eligibility Criteria:

The tenderer must have received contractual payments in the previous three financial years and the current financial year up to the date of inviting of tender, at least 150% of the advertised value of the tender. The tenderers shall submit Certificates to this effect which may be an attested Certificate from the concerned department / client or Audited Balance Sheet duly certified by the Chartered Accountant/Certificate from Chartered Accountant duly supported by Audited Balance Sheet.

(Note: Client certificate from other than Govt. Organization should be duly supported by Form 16A/26AS generated through TRACES of Income Tax Department of India).

3.4 Issue of Purchase Order:

- 3.4.1** The purchase order in favor of the successful bidder will be issued and shall constitute the intention of the purchaser to enter into contract with the bidder. The bidder should submit unconditional acceptance of PO along with SD/PBG within 30 days of issue of P.O.

3.5 Bill passing authority: ED/RP or GM/RP

Bill paying authority: GM/Finance/CO

3.6 SPLITTING OF QUANTITY-

The quantity to be ordered will be split by the Purchaser amongst various tenderers for ensuring better availability of material keeping in view the vital/critical nature of item, quantity to be procured, price and past performance of the firms with following condition:

- i) for MSEs as per clause 6.4.1 (3).
- ii) for Make in India as per clause 6.4.2.

Chapter 4

Technical specification of Material

1. The specification of material should be as per given in SOR.
2. The specification of material should conform to RDSO specs as per Specification no. given in SOR (wherever applicable) with latest amendment.
3. Material should be procured from RDSO approved source (wherever applicable) as per SOR.



Section- II

Chapter 5

OFFER LETTER

To

RailTel Corporation of India Limited,
6th Floor, Block-III, Delhi IT Park,
Shastri Park, Delhi-110053.

1. I/We _____ have read the various conditions detailed in tender documents attached here to and hereby agree to ABIDE BY THE SAID CONDITIONS. I/We also agree to keep this tender open for acceptance for a period of 60 days from the date of submission and in default thereof, I/We will be liable for forfeiture of my/our Earnest Money and I/We may be disqualified and banned for a period of three years and shall not be eligible to bid for future tenders in RailTel for the period of three years from date of issue of such orders. I/We offer to SUPPLY as per Bid Data Sheet at the rates quoted in the schedules and hereby bind myself/ourselves to complete the work within as per Bid Data Sheet from the date of issue of Purchase Order. I/We also hereby agree to abide by the Various Conditions of Contract and to carry out the supplies according to the Specifications for materials and works laid down by the RailTel.
2. A sum of **Rs. 76,800/-** has been submitted through IREPS portal is herewith forwarded as "Earnest Money". The full value of Earnest Money shall stand forfeited without prejudice to any other rights or remedies if, I/We withdraw or modify the offer within validity period or do not deposit the security deposit (Performance Bank Guarantee) within 30 days after receipt of orders to that effect.

SIGNATURE OF SUPPLIER (S)

Date:

CONTRACTOR (S) ADDRESS

SIGNATURE OF WITNESS:

- 1.
- 2.

Chapter 6

INSTRUCTIONS TO THE TENDERERS

For E-Tendering bids /information by bidders is to be submitted “Online” on e-Procurement Portal <https://www.ireps.gov.in>. Any document / information pertaining to this chapter will have to be submitted by the bidder on line. The digital signature of the tenderer on the e-tender form will be considered as confirmation that the tenderer has read, understood and accepted all the documents, unless special deviation is quoted by the tenderer in the technical & commercial deviation templates.

PLEASE NOTE

ALL COLUMNS SHOULD BE FILLED AND BLANK COLUMNS, IF ANY, SHOULD BE MARKED AS NIL.

PLEASE READ THE SCHEDULE OF REQUIREMENTS, INSTRUCTIONS TO THE TENDERERS, GENERAL & SPECIAL TENDER CONDITIONS, STANDARD CONDITIONS OF CONTRACT AND TECHNICAL SPECIFICATIONS OF SCHEDULE OF REQUIREMENTS BEFORE FILLING UP THE TENDER FORM CAREFULLY. PLEASE SIGN ON EACH PAGE.

THE TENDERERS MAY DOWNLOAD TENDER FORM FROM THE WEB SITE ‘www.railtelindia.com’ OR FROM THE e-Procurement Portal <https://www.ireps.gov.in>’,

NOTE: For online bid submission the tenderer will have to necessarily download an official online copy of the tender documents from e-Procurement Portal <https://www.ireps.gov.in>, and this should be done well before the deadline for bid-submission.

The Tender document consists of the following: -

Notice Inviting Tender

Section ‘I’

Chapter 1 Bid Data Sheet

Chapter 2 Schedule of Requirements (Price Schedule)

Chapter 3 Special Tender Conditions

Chapter 4 Technical Specifications

Section ‘II’

Chapter 5 Offer Letter

Chapter 6 Instructions to the Tenderers

Chapter 7 General Tender Conditions

Chapter 8 Standard Conditions of Contract

Chapter 9 Performa for Performance Bank Guarantee

Chapter 10 Check List

6.1. Offer Letter

- 6.1.1 The bidder shall complete the Offer Letter (Chapter-5) and the Price Schedule (Chapter-1) furnished in the bid document, indicating the goods to be supplied, description of the goods, associated technical literature, quantity and prices etc.
- 6.1.2 Bidders should enclose their credentials including supply of equipment/material to Reputed Telecom Operators or Government/PSUs. (Performa to be enclosed)

6.2 Instructions for Tender Document TO THE TENDERERS

- a) The RailTel reserves the right to verify all statements, information and documents submitted by the bidder in his tender offer, and the bidder shall, when so required by the RailTel, make available all such information, evidence and documents as may be necessary for such verification. Any such verification or lack of such verification, by the RailTel shall not relieve the bidder of its obligations or liabilities here under nor will it affect any rights of the RailTel there under.
- b) In case of any wrong information submitted by the tenderer, the contract shall be terminated, Performance Guarantee (PG) and Security Deposit (SD) of contract forfeited and agency barred for doing business on entire RailTel for 3 (three) years.
- c) The RailTel Tenders are published on www.railtelindia.com and on e-Procurement Portal <https://www.ireps.gov.in>. In addition to submitting the e-Tender documents online, they should also submit a cost of tender document through IREPS.

NOTE: For online bid submission the tenderer will have to necessarily download an official online copy of the tender documents from e-Procurement Portal <https://www.ireps.gov.in>, and this should be done well before the deadline for bid-submission.

6.3 Submission of Offers and Filling of Tender:

- a. Each and every page of bid should be digitally signed/signed in ink & stamped by authorized representative of the firm. Power of attorney in favour of the signatory duly authorizing the signatory shall be enclosed in the bid.
- b. The original copy of Power of attorney shall be submitted at the following address so as to reach up to 15:00 hours of due date:
**ED/RP, RailTel Corporation of India Limited,
6th Floor, Block-III, Delhi IT Park,
Shastri Park, Delhi-110053.**
- c. The envelope containing original copy of Power of attorney & Indemnity bond (if any) shall bear name of work, the tender no, and the words "DO NOT OPEN BEFORE" (due date). Without submission of original copy of Power of attorney before due date & time, the bid will be summarily rejected.

- d. The Tenderer should avoid over writings and corrections. However, if such corrections and over writings become inescapable, these are to be properly and legibly corrected. Offers with correction / over writing should be properly attested by the Tenderer at every correction.
- e. The unit rates quoted should be written both in words and figures. The unit of rates should be in metric system and as per tendered specification/schedule. In case of difference between words and figures, the rate in words will prevail. If there is a discrepancy between the unit price and total price that is obtained by multiplying the unit price and quantity, the unit price shall prevail and the total price shall be corrected by the purchaser accordingly.
- f. Tenderers are requested to go through the Standard Conditions, Special Conditions, Instructions to Tenderers, General Conditions carefully and note that, by submitting the tender documents, duly signed, they have accepted these conditions and undertake to abide by these conditions (unless specifically disagreed to clause wise).

6.4.0 Earnest Money Deposit (EMD)/Bid Security:

The tenderer shall deposit earnest money as per BID DATA SHEET through IREPS. Tenders without earnest money will be summarily rejected. No bank guarantee for EMD is accepted. Earnest Money of unsuccessful tenderers shall be returned after finalization of contract and that of successful tenderer after conclusion of Contract and securing Security Deposit if any.

6.4.1 For NSIC/MSME registered Firm

1. For small scale units registered with NSIC/MSME under single point registration Scheme and participating in this tender enquiry, following exemptions are available: -
 - (i) They are exempted from cost of tender documents.
 - (ii) They are also exempted from depositing Earnest money.

These exemptions are applicable provided units are registered with NSIC for tendered item and registration is current and valid. Firms claiming these exemptions are required to submit along with their offer, copy of their current and valid NSIC registration certificate for the tendered item, otherwise their offer would not be considered.

Eligible MSEs are exempted from cost of tender documents and EMD. No other exemption will be given. Submission of Udyam Registration is mandatory to avail this exemption.

2. No exemption is, however, applicable to these units from payment of security deposit/ Performance Bank Guarantee.

3. The participating MSEs in a tender, quoting price within the band of L1+15% shall also be allowed to supply a portion of the requirement by bringing down their prices to the L1 price, in situation where L1 is from someone other than an MSE. Such MSEs shall be allowed to supply up to 25% of the total tendered value. In case of more than one such eligible MSE, the supply will be shared equally.

NOTE:

This bid complies with “Public Procurement (preference to make in India) Policy Order, 2017 issued by DIPP and Public Procurement Policy for Micro and Small Enterprises (MSEs) order, 2012” issued by MoSME.”

The bidders claiming the preference have to submit relevant documents prescribed under relevant order.

6.4.2 Make in India clause

Public Procurement (Preference to Make in India): Applicable only for all Global tenders & for all tenders where the minimum local content shall be 50% & tenders valuing above Rs. 5 Lakhs.

The provisions of Public Procurement (Preference to Make in India), Order-2017 dt. 15.06.2017 or latest is applicable.

6.4.2.1 (a) Local content: The minimum local content shall be 50% or as indicated in the tender enquiry.

(b) Margin of Purchase Preference: The margin of purchase preference is 20%.

(c) Fee for complaints: Fee for filing a complaint under the order shall be Rs.10,000/- per case. The complaint shall be filed in the office of the Director RailTel. The fee shall be deposited with the office of the Director Finance/RailTel, New Delhi.

6.4.2.2 Verification of local content:

a. The local supplier at the time of tender, bidding or solicitation shall be required to provide self-certification that the item offered meets the minimum local content and shall give details of the location(s) at which the local value addition is made.

b. In case of procurement for a value in excess of Rs.10 Crores, the local supplier shall be required to provide a certificate from the statutory auditor or cost auditor of the company (in the case of companies) or from a practicing cost accountant or practicing chartered accountant (in respect of suppliers other than companies) giving the percentage of local content.

c. False declarations will be in breach of the Code of integrity under Rule 175(1)(i)(h) of the General Financial Rules for which a bidder or its successors can be debarred for up to two years as per Rule 151 (iii) of the General Financial Rules along with such other actions as may be permissible under law.

d. A Supplier who has been debarred by any procuring entity for violation of this order shall not be eligible for preference under this Order for procurement by any other procuring entity for the duration of the debarment.

e. Debarment of bidders: In respect of procuring entities other than the one which has carried out the debarment, the debarment takes effect prospectively from the date of uploading on CPPP so that ongoing procurements are not disrupted.

6.4.2.3 Requirement of Purchase Preference: Subject to the provisions of this Order and to any specific instructions issued by the Nodal Ministry or in pursuance of this Order, purchase preference shall be given to local suppliers in all procurements undertaken by procuring entities in the manner specified hereunder:

a. In procurement of goods in respect of which the Nodal Ministry has communicated that there is sufficient local capacity and local competition, and where the estimated value of procurement is Rs.50 Lakhs or less, only local suppliers shall be eligible. If the estimated value of procurement of such goods is more than Rs.50 Lakhs, the provisions of sub-paragraph b or c as the case may be, shall apply.

b. In the procurements of goods which are not covered by paragraph (a) above and which are divisible in nature, the following procedure shall be followed:

i) Among all qualified bids, the lowest bid will be termed as L1. If L1 is from a local supplier, the contract for full quantity will be awarded to L1.

ii) If L1 bid is not from a local supplier, 50% of the order quantity shall be awarded to L1 Thereafter. The lowest bidder among the local suppliers will be invited to match the L1 price for the remaining 50% quantity subject to the local supplier's quoted price falling within the margin of purchase preference, and contract for that quantity shall be awarded to such local supplier subject to matching the L1 price. In case such lowest eligible local supplier fails to match the L1 price or accepts less than the offered quantity, the next higher local supplier within the margin of purchase preference shall be invited to match the L1 price for remaining quantity and so on, and contract shall be awarded accordingly. In case some quantity is still left uncovered on local suppliers, then such balance quantity may also be ordered on the L1 bidder.

c. In procurements of goods not covered by sub-paragraph (a) above and which are not divisible, and in procurement of services where the bid is evaluated on price alone, the following procedure shall be followed:

i). Among all qualified bids, the lowest bid will be termed as L1. If L1 is from a local supplier; the contract will be awarded to L1.

ii). If L1 is not from a local supplier, the lowest bidder among the local suppliers will be invited to match the L1 price subject to local supplier's quoted price falling within the margin of purchase preference, and the contract shall be awarded to such local supplier subject to matching the L1 price.

iii) In case such lowest eligible local supplier fails to match the L1 price, the local supplier with the next higher bid within the margin of purchase preference shall be invited to match the L1 price and so on and contract shall be awarded accordingly. In case none of the local suppliers within the margin of purchase preference matches the L1 price, then the contract may be awarded to the L1 bidder.

6.4.2.4 Exemption of small purchases: Notwithstanding anything contained in Para 6.4.2.3,

procurements where the estimated value to be procured is less than Rs.5 Lakhs is exempted.

6.4.3 Updation of Labour data on Railway's shramikkalyan Portal

- A. Contractor is to abide by the provisions of Payment of Wages Act & Minimum Wages Act in terms of clause 54 and 55 of Indian Railways General Condition of Contract. In order to ensure the same, an application has been developed and hosted on website 'www.shramikkalyan.indianrailways.gov.in'. Contractor shall register his firm/company etc. and upload requisite details of labour and their payment in this portal. These details shall be available in public domain. The Registration/updation of Portal shall be done as under:
- (a) Contractor shall apply for one-time registration of his company/firm etc. in the Shramikkalyan portal with requisite details subsequent to issue of Letter of Acceptance. Engineer shall approve the contractor's registration on the portal within 7 days of receipt of such request.
 - (b) Contractor once approved by any Engineer, can create password with login ID (PAN No.) for subsequent use of portal for all LOAs issued in his favour.
 - (c) The contractor once registered on the portal, shall provide details of his Letter of Acceptance (LoA)/Contract Agreements on shramikkalyan portal within 15 days of issue of any LoA for approval of concerned engineer. Engineer shall update (if required) and approve the details of LoA filled by contractor within 7 days of receipt of such request.
 - (d) After approval of LOA by Engineer, contractor shall fill the salient details of contract labours engaged in the contract and ensure updating of each wage payment to them on shramikkalyan portal on monthly basis.
 - (e) It shall be mandatory upon the contractor to ensure correct and prompt uploading of all salient details of engaged contractual labour & payments made thereof after each wage period.
- B. While processing payment of any 'On Account bill' or 'Final bill' or release of 'Advances' or 'Performance Guarantee / Security deposit', contractor shall submit a certificate to the Engineer or Engineer's representatives that "I have uploaded the correct details of contract labours engaged in connection with this contract and payments made to them during the wage period in Railway's Shramikkalyan portal at 'www.shramikkalyan.indianrailways.gov.in' till _____ Month, _____ Year."

6.5 Security Deposit/Performance Bank Guarantee:

The tenderer shall submit 10% of total value of the Contract towards security deposit in the form of FDR or online transfer or irrevocable Bank Guarantee within 30 days of issue of Purchase Order, failing which a penal interest of 15% per annum shall be charged for the delay period i.e. beyond 30 (thirty) days from the date of issue of LOA/PO, from any scheduled bank for due fulfillment of contract

- i) Security Deposit/Performance Bank Guarantee of 10% of LOA/PO value of the contract is required to be submitted within 30 days of issue of LOA/PO with validity of 3 months

beyond warranty period. This PBG shall be submitted by the contractor at RCIL's Office address as given in Bid Data Sheet.

- ii) The security deposit/Performance Bank Guarantee shall be released after successful completion of Contract including warranty period obligations under the contract and receiving of PBG against AMC (if applicable), duly adjusting any dues recoverable from the tenderer. The security deposit shall bear no interest.

Note:

- 1) A separate advice of the BG will invariably be sent by the BG issuing bank to the RailTel's Bank through SFMS and only after this the BG will become acceptable to RailTel. It is therefore in own interest of bidder to obtain RailTel's bank IFSC code, its branch and address and advise these particulars to the BG issuing bank and request them to send advice of BG through SFMS to the RailTel's Bank.
- 2) Any performance security upto a value of Rs. 5 Lakhs is to be submitted through online transfer only in RCIL bank account.
- 3) In case of submission of Security Performance in form of FDR then lien should be created in favor of "RailTel Corporation of India Ltd.".

6.6 No Interest on Earnest Money and Performance Security:

No interest shall be paid on the amount of earnest money and Performance Security held by the RailTel, at any stage.

6.7 Fax Quotations & Late Tenders:

Fax Tender documents and Late/Delayed tenders would not be considered.

6.8 Drawings and Specifications:

If any tenderer happens to quote with their own Drawing No / Part No / Specification, then, they shall have to, necessarily, submit all the requisite documents and information, in support of their offer being in conformity with the tender Drawing / Specification. Furthermore, duly authenticated copies of such drawings / specifications / catalogue are also to be enclosed, failing which the offer will be liable to be rejected.

6.9 Attendance of Representatives for Tender Opening:

Representatives of tenderers desirous to attend the tender opening can do so on production of a proper letter of authority from the respective firm, failing which they may not be allowed to attend the tender opening. In addition, representatives desirous of attending the Online Public Tender Opening Event can do so by getting authorized for such participation by the Super-User/ Master User of their respective organizations on ETS. Authorized representatives of those firms who have submitted the tender documents alone shall be allowed to attend the tender opening.

6.10 Other Particulars to be enclosed along with tender:

Following details should also be enclosed along with the tender:-

- i) Performance statement of last three years for supply of same or similar items to Railways, BSNL, MTNL, Government PSU's & Telecom Service Providers. This Performance Statement is to be submitted in following format:-

| Year | PO. No. & Date with description of item | Name of the purchaser | Qty. ordered | Date of delivery in the Purchase Order | Qty. supplied within scheduled date of delivery | Qty. supplied during 1st extension | Qty. supplied during 2nd extension | Qty. supplied during 3rd extension |
|------|---|-----------------------|--------------|--|---|------------------------------------|------------------------------------|------------------------------------|
| 1 | 2 | 3 | 4 | 5 | 6 | 7 | 8 | 9 |

They may be deprived of any order against this tender if the information furnished is found to be incorrect later on. Correct status/supply position of pending orders, if any, should be invariably indicated. Supporting documents are to be enclosed. Photocopies of the supply/purchase orders along with the Inspection Certificates and Receipt Notes should be enclosed for ready reference, along with tender to substantiate their past performance.

- ii) Complete Tender documents duly signed & stamped on each page in token of acceptance should be submitted online.

6.11 Rate, Taxes and Duties: -

6.11.1 Tenderer should submit offer on CIP destination basis. Tenderers should clearly indicate separately ex-works basic price, packing charges, forwarding charges, CGST/SGST/IGST/GST, Freight and insurance charges up to destination, applicable for each unit tendered.

6.11.2 Tenderers are requested to quote under the following terms: -

The tenderers are required to quote in the same rate units/ Sets etc. as given in the tender schedule. Any deviation in this aspect will make the offer liable to be ignored.

6.11.3 Tenderer should submit firm price offer. Price quoted by the bidder shall remain fixed during the entire period of contract. The offer shall be firm in Indian Rupees. No Foreign exchange will be made available by the purchaser.

6.12 GST related clause:

6.12.1 If any tenderer desires to ask for CGST/SGST/IGST/GST to be paid extra, the same must be specifically stated. In the absence of any such stipulation in the tender it will be presumed that the prices quoted by the tenderer are inclusive of all taxes and no liability for payment of the CGST/SGST/IGST/GST will be devolved upon the purchaser.

6.12.2 CGST/SGST/IGST/GST should be quoted extra if applicable.

a) While quoting the rates, tenderer should pass on (by way of reduction in prices) the set off/input tax credit that would become available to them duly stating the quantum of such credit per unit of the item quoted for.

b) The tenderer while quoting for tenders should give the following declaration:

“We agree to pass on such additional set off/input tax credit as may become available in future in respect of all the inputs used in the manufacture of the final production in price and advise the purchaser accordingly”.

The supplier while claiming the payment shall furnish the following certificate to the paying authority.

“We hereby declare that additional set off/input tax credit to the tune of Rs. _____ has accrued and accordingly the same is being passed on to the purchaser and to that effect the payable amount may be adjusted.”

If any surcharge on tax is applicable the same should be indicated clearly.

6.12.3 The price quoted in the offer should be firm, fixed indicating the breakup and inclusive of all taxes & duties like import, custom, Anti-Dumping, CGST, SGST, IGST, UTGST etc. The offer should be inclusive of packing, forwarding, freight up to destination, insurance charges.

6.12.4 Bidder shall issue valid tax invoice to RailTel for availing proper credit of CGST, SGST, IGST, UTGST incase of award of Contract. GST will not be reimbursed in the absence of valid tax invoice.

6.12.5 For all the taxable supplies made by the vendor, the vendor shall furnish all the details of such taxable supplies in the relevant returns to be filed under GST Act.

6.12.6 If the vendor fails to comply with any of the above, the vendor shall pay to purchaser any expense, interest, penalty as applicable under the GST Act.

6.12.7 In case of incorrect reporting of the supply made by the vendor in the relevant return, leading to disallowance of input credit to purchaser, the vendor shall be liable to pay applicable interest under the GST Act to the credit of purchaser. The same provisions shall be applicable in case of debit/credit notes.

6.12.8 Tenderer shall quote all-inclusive rates, but there shall be break up of basic price and all type of applicable taxes such as CGST, SGST, IGST, UTGST along with respective HSN/SAC Code under GST Law (including tax under reverse charges payable by the recipient).

6.12.9 Wherever the law makes it statutory for the Purchaser to deduct any amount towards GST at source, the same will be deducted and remitted to the concerned authority.

6.12.10 In regards to works contract, the tenderer should have registration no. for GST in respective state where work is to be executed and shall furnish GST registration certificate along with Tender.

6.12.11 The imposition of any new tax and/or increase/in the aforesaid taxes, duties levies, after the last stipulated date for the receipt of tender including extensions if any and the bidder there upon necessarily and properly pays such taxes/levies/cess, the bidder shall be reimbursed the amount so paid, provided such payments, if any, is not, in the opinion of RailTel attributable to delay in execution of work within the control of bidder. The bidder shall, within a period of 30 days of the imposition of any such tax or levy or cess, give a written notice thereof to RailTel that the same is given pursuant to this condition, together with all necessary information including details of input credit relating thereto. In the event of non-payment/ default in payment of any of the above taxes, RailTel reserves the right to with-hold the dues/payments of bidder and make payment of State/Central Government authorities as may be applicable. However, if the rates are reduced after the last stipulated date for receipt of tender, bidder has to pass on the benefits to RailTel.

6.13 In case of imported equipment: - Deleted

6.14 The tenderers are to indicate the Income-Tax PAN details and enclose a Photocopy of the same as governed by extant rules of the Government of India.

6.15 **Validity:** Tenderers are to keep validity of their offer open for a minimum period as per bid data sheet. Offers with validity period of shorter duration would be taken as non-responsive and rejected.

6.16 Evaluation Criteria:

i) Rates quoted by the Tenderers with discounts, if any, linked to quantity will not be considered for determining inter-se position of the offers. Discounts with conditions attached to early payment, early Receipt/ Accountal etc., will also not be considered for determining inter-se position of the offers. However, RailTel may avail the discounts linked to quantity, early payment, early receipt/ Accountal etc. if otherwise, firm's offer is found to be acceptable.

ii) Inter se position of the offers will be determined on total unit rate on CIP destination basis which will include basic rate, custom duty, CGST, SGST, IGST, GST, freight, insurance and any other charge or cost quoted by the tenderer, including GST payable.

On reverse charge by RailTel, wherever applicable.

iii) **Evaluation will be done Total-value-wise not item-wise.**

6.17 The Special Tender Conditions, wherever, they differ from General and Standard Conditions will override the later.

6.18 Compliance & Deviation statements:

Compliance statement for acceptance of the Technical Specifications (Chapter4) and Instructions & Conditions (Chapter3, Chapter 6, Chapter 7 and Chapter 8) shall be enclosed by the tenderer with the offer along with the technical literature of the material and other documents in support of relevant clauses. Deviation statement, if any, (Chapter-wise and Clause-wise) from these technical Specification & Tender conditions should also be submitted wherever tenderer wishes to deviate from these conditions.

6.19 Tenderer's Comments:

Any comments which the tenderer desires to make shall take the form of a separate statement in English and giving reference to page, clause or item numbers and shall be submitted along with the tender.

6.20 Tax deducted at Source:

Statutory deduction of taxes would be made as per the prevalent rules .The PAN number may be furnished invariably.

6.21 Addenda / Corrigenda:

Addenda / Corrigenda to the tender documents may be issued by RailTel prior to the date of opening of the tenders, to clarify or reflect modifications in the contract terms and conditions or in the design. Such addendum/corrigendum shall be available on IREPS's e-Procurement Portal only. Tenderers who are unable or unwilling to bring their tenders to conform to the requirements of the RailTel are liable to be rejected.

6.22 Ambiguity:

If there is any ambiguity or doubt as to the meaning of any of the tender clauses/ conditions or if any additional information required, the matter should immediately be referred to the RailTel in writing.

6.23 Bid submission and Opening (On Line Only)

6.23.1 Bid Security/EMD should be submitted as per clause 6.4. Bids without EMD will be summarily rejected.

6.23.2 The bid should be submitted online with all the required documents and Annexures mentioned in the tender along with supporting documents. All the documents, Annexures

and supporting documents should be duly signed and stamped. The bid should consist of following:

1. Power of attorney in favour of the signatory duly authorizing the signatory. Scan copy is to be uploaded online. Original copy is needed to be submitted by the bidder before due date & time, without submission of original copy, the bid will be summarily rejected.
2. Complete Tender documents, digitally signed or duly signed & stamped on each page in token of acceptance should be submitted online.
3. Compliance statement for acceptance of Technical specification (Chapter 4) & Instructions and Tender Conditions (Chapter 3, 6, 7, 8).
4. Deviation Statement, if any (Chapter wise and Clause wise from Technical Specification & Tender conditions).
5. Performance statement including Copies of Purchase Orders & Inspection certificates as per clause 6.10 Chapter 6.
6. Offer letter, Chapter-5.
7. NSIC/MSME certificate, clause-6.4.1, Chapter-6.
8. Bid Security/EMD.

Note: Non submission of the above-mentioned documents may lead to rejection of the bid.

6.23.3 The tenderer's bids will be opened at the time & date of opening of the tender given in Bid Data Sheet (BDS) online in the presence of such Tenderers/Representatives who choose to be present online. The Tenderers/Representatives can also choose to be physically present in the office of RailTel for the Online Public Tender Opening Event.

6.24 Price Variation Clause:

PVC clause is not applicable in this Tender.

*****.



CHAPTER-7**7.0 GENERAL TENDER CONDITIONS****7.1 Acceptance of the Offers: -**

The RailTel is not bound to accept the lowest or any offer and reserve to itself the right to accept any offer in respect of the whole or any portion of the item specified in the tender and contractor shall be required to supply at the rate quoted.

7.2. Quantity to be ordered: -

a) The purchaser shall be at liberty to enhance or reduce the value/quantity mentioned in the LOA/PO as indicated in SOR Chapter 2 without assigning any reasons based on requirement. The bidder shall comply with such modifications unconditionally provided these are made before completion of the deliveries under the LOA/PO. Any such change in value/quantity shall have no impact on the rates mentioned in the LOA/PO for any such item.

b) RailTel will enter into Rate Contract with the successful firm to whom the contract is awarded for catering of requirement of Material. During the validity of Rate Contract, RailTel will place Sub Purchase Orders for Material detailed in SOR, as per requirement. The total variation under Rate Contract +/- 25% of contract value shall be restricted for these SOR items. The supplier shall have to supply material against these Purchase Orders within 60 days from the date of issue of such Purchase Orders.

7.3 Quotations for Imported items: -**7.3.1 Imported Stores offered by Indian Agents in Indian Currency:**

Any authorized dealer / agent / recognized industrial distributor quoting on behalf of their Foreign principal in Indian Rupees shall have to comply with the following:-

- a) To quote with tender specific authorization from the foreign manufacturer.
- b) (i) While quoting on behalf of foreign principals' tenderers are required to furnish the principal's invoice / Performa invoice along with their quotation.
(ii) Performa invoices however, may be accepted in exceptional cases where, it is not possible to obtain the invoices before the contract is placed.
- c) The tenderer shall have to undertake in the tender to comply with the following

- i) Consent to furnish copy of customs out passed bill of entry for the goods, relevant to each consignment, Manufacturer's Test and Guarantee certificate issued by the manufacturer, Copy of Bill of Lading/AWB relevant to the consignment; Copy of commercial invoice of the foreign manufacturer/principals relevant to each consignment.
- ii) Current and valid authorization/dealership certificate of foreign manufacturer/ principal.
- iii) Compliance of sea/air worthy packing condition in manufacturer's original packing with manufacturer's tamper proof seal and compliance of the Packing condition as laid down in Standard Conditions of Contract Para-8.16.0

Failure to comply with any of the aforesaid conditions as referred above will make the offer liable to be rejected.

7.3.2. Deleted

7.3.3 Tenderer has to indicate the following while submitting the offer:

- a) The precise relationship between the foreign manufacturer/principal and their agents/ associates.
- b) The mutual interest which the manufacturer/principal and the Indian agent / associates have in business of each other is to be indicated.
- c) Indian agent's Permanent Account Number is to be indicated.

7.4 Payment Terms:

Payment against receipt, inspection and acceptance of the material by the consignee at the destination, subject to submission of Performance Bank Guarantee by the firm for a value of 10% of PO value of the stores with validity 3 months beyond warranty period of supply. The Supplier while claiming the payment will furnish the following certificate to the paying authorities. We hereby declare that additional duties set offs/ input tax credit to the tune of Rs... has accrued and accordingly the same is being passed on to the purchaser and to that effect the payable amount may be adjusted, accompanied with the following documents and any other documents mentioned in the contract:

- (i) Tax Invoice (IRN GST invoice) or declaration for non-availability of IRN. (ii) Delivery Challan (iii) contractor's certificate of dispatch (iv) Packing list (wherever applicable) (v) Factory Test Report (wherever applicable) (vi) Insurance Certificate for transit period (wherever applicable) (vii) Inspection certificate in original (viii) Consignee's receipt (ix) Warranty guarantee certificate of OEM (wherever applicable)

(x) OEM's certificate that the materials/equipment supplied is as per specification/ the quantity material supplied is as per the SOR (wherever applicable).

7.4.1 In case of Supply and Installation:

- a) 80% of the value of the part supply of materials on receipt by the consignee at site duly inspected and accompanied with valid documents.
- b) Balance 20% of the value of the part supply on successful installation and commissioning at site. Bidder has to install and commission the equipment within 30 days from the communication by RailTel EIC (Engineer In-Charge). In case installation and commissioning is delayed on account of RailTel then 20% payment can be released after submission of a Bank Guarantee of equal amount valid for a period of one year.

7.5 Inspection:

- 7.5.1** The supplier/manufacture shall send inspection call letter when the material is ready to be supplied and ready for inspection. The Inspection shall be carried out at supplier's/Manufacturer's premises by the Inspecting Authority.
- 7.5.2** The supplier/manufacture shall submit along with inspection call the details of test procedures, test programs, test parameters together with permitted values, etc., and their Quality Assurance Plan.
- 7.5.3** In case material/equipment fails during inspection, the fresh lot of same material/equipment shall be offered without any extra cost, by the manufacturer/supplier. In such a case, total cost of re-inspection including travel, lodging & boarding of the inspecting officials shall be to manufacturer's / supplier's account/cost.
- 7.5.4 Inspection by RDSO**
- 7.5.5** RDSO inspection charge shall be borne by RailTel, but necessary facilities to carry out test /witness inspection shall be provided by the manufacturer/supplier, free of cost. If inspection charge will be paid by Supplier, payment will be made on production of proof of inspection charge payment to RDSO and submission of Tax invoice.
- 7.5.6** The manufacturer shall maintain stock register (receipt, issue and balance) and defect records for the raw material. The defect records shall be in standard formats and it shall be compiled on a daily/ weekly/ monthly basis and it shall be analysed. "NIL" Report shall be segregated from the accepted material. First-in First-out concept shall be implemented in foolproof manner. The batches of the raw material shall be identified and traceable. All relevant documents necessary to ensure trace-ability shall be maintained. The raw material shall be protected from direct exposure to sunlight, moisture, water ingress and heat etc.

7.5.7 Finished products shall be tested 100% by the factory QC personnel before being offered to RailTel for acceptance to ensure that it meets all quality requirements as per the relevant specifications. Duly filled in test formats indicating the results of such tests shall be submitted along with material offered for inspection to RailTel.

7.6 Terms of Delivery:

- a) Mode of dispatch should be by road / reputed courier / in person through the authorized representative of the Tenderer.
- b) Tenderer shall submit the offer clearly on CIP destination basis.
- c) Transit Insurance for risk in transit should be arranged by the supplier, since risk in transport in all such cases rests with the supplier.

7.7 Delivery Schedule

- a) The tenderer should note the required delivery schedule of RailTel given in the tender schedule /offer form and quote accordingly. Vague Delivery terms must be avoided and if quoted will be taken as commercially unresponsive to RailTel's requirement.
- b) Time for and the Date of delivery as specified in tender schedule /offer form is the essence of the Contract. However, extension of Delivery date may be considered in deserving cases where genuine reasons exist. Such extensions of delivery date may be considered with or without Liquidated damages and Denial Clause as per Standard conditions of Contract.
- c) Recover from the Contractor as agreed liquidated damages and not by way of penalty a sum equivalent to half per cent of the price of any stores (including elements of taxes, duties, freight, etc.) which the Contractor has failed to deliver within the period fixed for delivery in the contract or as extended for each week or part of a week during which the delivery of such stores may be in arrears where delivery thereof is accepted after expiry of the aforesaid period **The upper limit for recovery of liquidated damages will be 10% (Ten Percent) of Total contract value provided in the contract.**

7.8 Deleted.

7.9 Marking of Material Supplied:

The tenderer should agree to indicate the Manufacture's Name, Month and Year of manufacturing by casting/stamping/etching/embossing, at an appropriate place of each piece supplied, without affecting the functional utility and structural stability of the components/material.

7.10 RailTel Regions details:

| S N | Region | Regional offices | Addresses | States |
|-----|-----------------|------------------|--|---|
| 1. | Northern Region | New-Delhi | Regional General Manager 6th Floor, 3 rd Block, Delhi Technology Park, Shastri Park, Delhi-110053 | Haryana, Rajasthan, Uttar Pradesh, Delhi, Jammu & Kashmir, Punjab, Madhya Pradesh, Himachal Pradesh, Uttanchal . |
| 2. | Eastern Region | Kolkatta. | Regional General Manager. 3rd Floor, Chatterjee International Centre, 33-A Jawaharlal Nehru Road, Kolkatta-700071. | West Bengal , Orissa , Bihar , Madhya Pradesh, Chattisgarh, Jharkhand, Assam, Tripura, Meghalaya, Manipur , Mizoram, Arunachal, Nagaland. |
| 3. | Southern Region | Secunderabad | Regional General Manager 2nd Floor B-Block, Rail Nilayam, Secunderabad- 500071. | Andhra Pradesh, Tamil Nadu ,Karnataka, Kerala, Pondicherry. |
| 4 | Western Region | Mumbai | Regional General Manager Western Railway Microwave Complex, Senapati Bapat Marg, Mahalaxmi, Mumbai- 400013. | Gujarat, Maharashtra, Karnataka, Rajasthan, Madhya Pradesh, Goa. |

Each Region is headed by Executive Director (ED) /Regional General Manager (RGM), under whom, Additional General Manager / Deputy General Managers (Referred as DGM's) are working.

7.11 The requirement of the Tendered stores may be at any location within the Region indicated in clause 7.11.

7.12 Purchaser's right to accept any Bid and to reject any or all Bids:

The Purchaser reserves the right to accept or reject any bid, to annul the process at any time prior to award of contract and without thereby incurring any liability to the affected bidder or bidders on the grounds of the Purchaser's action.

7.13 Issue of Confirmed Supply Orders:

RailTel will issue the Supply Orders within validity period of contract Agreement/Advance Purchase order.

7.14 Force Majeure Clause:

In the event of either party being rendered unable by force majeure conditions to perform any obligation to be performed by them under the contract, the relative obligation of the party affected by such force majeure shall upon notification to the other party be suspended for the period during which force majeure events last. The cost and loss sustained by either party shall be borne by respective parties.

The term force majeure employed herein shall mean Act of God, war (declared or not), storms, floods, tsunami, restraints imposed by Governments, Riots, Strikes, Go Slow, Lock Out or any labour unrest at the works of the contractor (to be substantiated by the contractor with document), civil commotion, fire, accident, sabotage, earthquake or any other natural calamities, plague, quarantine, import or export embargoes, or change in Govt. policies or the like circumstances or any happening affecting the performance by the contractor or it's obligations under this contract which, in the opinion of the RailTel, the contractor cannot reasonably prevent or control against.



Chapter 8

STANDARD CONDITIONS OF CONTRACT**8.0 Definitions and Interpretation.**

8.0.1 In the Contract, unless the context otherwise requires;

8.0.2 "Acceptance of Tender" means the letter of memorandum communicating to the Contractor the acceptance of his tender and includes an advance acceptance of his tender;

8.0.3 "Consignee" means where the stores are required by the acceptance of tender to be dispatched by rail, road, air or steamer, the person specified in the Acceptance of Tender to whom they are to be delivered at the destination; Where the Stores are required by the acceptance of tender to be delivered to a person as an interim consignee for the purpose of dispatch to another person, such other persons; and in any other case the person to whom the stores are required by the acceptance of tender to be delivered in the manner therein specified.

8.0.4. "Contract" means and includes the invitation to tender, instructions to tenderers, acceptance of tender, Standard Conditions of Contract, Special Conditions of Contract, particulars and the other conditions specified in the acceptance of tender and includes a repeat order which has been accepted or acted upon by the contractor and a formal agreement if executed;

8.0.5. The "Contractor" means the person, firm or company with whom the order for the supply is placed and shall be deemed to include the contractor's successors (approved by the Purchaser), representatives, heirs, executors and administrators as the case may be, unless excluded by the terms of the contract

8.0.6. "The Sub-contractor" means the person, firm or company from whom the Contractor may obtain any material or fittings to be used in the supply or manufacture of the stores;

8.0.7. "Drawing" means the drawing or drawings specified in or annexed to the Schedule or Specifications

8.0.8. "Government" means the Central Government or a State Government, as the case may be;

8.0.9. "The Inspecting Officer" means the person specified in the contract for the purpose of Inspection of stores or work under the contract and includes his authorized representative;

8.0.10. "Material" means anything used in the manufacture or fabrication of the stores

8.0.11. "Particulars" include-

(a)"Specifications" shall mean all directions, various technical specifications, provisions and requirements attached to the contract, as originally agreed and as modified from time to time by RailTel subject to price adjustments mutatis mutandis which pertain to the method and manner of performing the work or works to the quantities and qualities of the work or works and the materials to be furnished under the contract for the work or works as may be amplified or modified by RailTel-in-charge during the performance of the contract in order to provide for unforeseen conditions or in the best interest of the work or works. It shall also include the latest edition including all addenda / corrigenda of relevant Bureau of Indian standard specifications and other relevant codes governing a particular activity or facility. The term shall include the specifications specified in the contract in respect of each type of material/goods to be used in the execution of contract.

(b) Drawings

(c) Pattern bearing the seal and signature of the Inspecting Officer (hereinafter called the sealed pattern) which shall include also a certified copy thereof sealed by the Purchaser for the guidance of the Inspecting Officer;

(d) Sample sealed by the Purchaser for guidance of the Inspecting Officer (hereinafter called the certified sample) which shall include a certified copy thereof sealed by the Purchaser for the guidance of the Inspecting Officer;

(e) Trade pattern, that is to say, a pattern, stores conforming to which are obtainable in the open market and which denotes a standard of the Indian Standard Institute or other standardizing authority or a general standard of the industry:

(f) "Proprietary mark "or "brand" means the mark or brand of a product which is owned by an industrial firm;

(g) Any other details governing the construction, manufacture or supply of stores as may be prescribed by the contract;

8.0.12. " Purchase Officer" means the officer signing the acceptance of tender and includes any officer who has authority to execute the relevant contract on behalf of the Purchaser.

8.0.13. " The Purchaser "means RailTel Corporation of India Limited with its corporate office acting through Chairman & Managing Director or his authorized officer.

8.0.14. "Signed" includes stamped, except in the case of an acceptance of tender or any amendment thereof

8.0.15. "Site" means the place specified in the contract at which any work is required to be executed by the contractor under the contract or any other place approved by the Purchaser for the purpose;

- 8.0.16.** "Stores" means the goods specified in the contract which the contractor has agreed to supply under the contract;
- 8.0.17.** "Supply Order" means an order for supply of stores and includes an order for performance of service;
- 8.0.18.** "Test" means such test as is prescribed by the particulars or considered necessary by the Inspecting Officer whether performed or made by the Inspecting Officer or any agency acting under the direction of the Inspecting officer;
- 8.0.19.** "Unit" and "Quantity" means the unit and quantity specified in the contract;
- 8.0.20.** "Engineer / Engineer-in-Charge" Shall mean an executive of RailTel in charge of works and shall include the superior executives of RailTel. He is responsible for ensuring that all fieldworks covered by the contract are carried out in accordance with approved designs, drawings & specifications and conditions of contract as agreed to. "Engineer's Representative" Shall mean the supervisor of RailTel in direct charge of the works.
- 8.0.21.** The delivery of the stores shall be deemed to take place on delivery of the stores in accordance with the terms of the contract, after approval by the Inspecting Officer if so provided in the contract to
- (a) The consignee at his premises; or
 - (b) Where so provided the interim consignee at his premises, or
 - (c) A carrier or other person named in the contract for the purpose of transmission to the consignee, or
 - (d) The consignee at the destination station in case of contract stipulating for delivery of stores at destination station.
- 8.0.22.** "RailTel" Means M/s. RailTel Corporation of India Limited, which includes all the subordinate offices in Regions and territories.
- 8.0.23.** Deleted
- 8.0.24.** "Tenderer" or "Bidder" Means and includes any firm of engineers or Contractors or any company or body, corporate or otherwise, who submit the Tender which has been invited.
- 8.0.25.** "Work or Works" Means all or any of the items of the work for which the Tenderer/ Contractor has Tendered/contracted according to the specifications, drawings annexed or to be implied there from, or incidental thereto or to be hereafter specified or required in such explanatory instructions and drawings, being in conformity with the original specifications, drawings, Annexure and schedules and also such instructions and drawings additional to the aforementioned as may from time to time be issued by the Purchaser's Engineer during the progress of the contracted work.

- 8.0.26.** "Bid" or "Tender" shall mean the proposal/document that the BIDDER submits as his offer with price and conditions in the requested and specified format as detailed in 'Specifications' / 'Tender documents
- 8.0.27.** "Purchaser's Engineer" Means the Chairman & Managing Director of RailTel or successor who will decide all matters relating to design, manufacture, installation and commissioning of the plant and equipment at site.
- 8.0.28.** "CIP (Carriage & Insurance Paid) Destination" means the date of delivery would be the date on which the delivery is affected at the consignee's end within any of the RailTel's Region.
- 8.0.29.** Words in the singular include the plural and vice versa
- 8.0.30.** Words importing the masculine gender shall be taken to include the feminine gender and words importing persons shall include any company or association or body of individuals, whether incorporated or not;
- 8.0.31.** The heading of these conditions shall not affect the interpretation or construction thereof;
- 8.0.32.** Terms and expression not herein defined shall have the meanings assigned to them in the Indian Sale of Goods Act, 1930 (as amended), or the Indian Contract Act, 1872 (as amended) or the General Clauses Act, 1897 (as amended), as the case may be.
- 8.1.0 Parties-**The parties to the contract are the Contractor and the Purchaser, as defined in Clauses 8.0.5 and 8.0.13.
- 8.1.1.** Authority of person signing the Contract on behalf of the Contractor-A person signing the tender or any other document in respect of the Contract on behalf of the Contractor without disclosing his authority to do so shall be deemed to warrant that he has authority to bind the Contractor. If it is discovered at any time that the person so signing has no authority to do so, the Purchaser may, without prejudice to any other right or remedy of the Purchaser, cancel the contract and make or authorize the making of a purchase of the stores at the risk and cost of such person and hold such person liable to the Purchaser for all costs and damages arising from the cancellation of the contract including any loss which the Purchaser may sustain on account of such purchase. The provisions of Clause 8.6.0 and 8.6.2 shall apply to every such purchase as far as applicable.
- 8.1.2.** Address of the Contractor and notices and communications on behalf of the Purchaser: -
- (a) For all purposes of the contract, including arbitration there under, the address of the Contractor mentioned in the tender shall be the address to which all communications addressed to the Contractor shall be sent, unless the Contractor has notified change by a separate letter containing no other communication and sent by registered post acknowledgement due to the Purchaser. The Contractor

shall be solely responsible for the consequence of an omission to notify a change of address in the manner aforesaid.

- (b) Any communication or notice on behalf of the Purchaser in relation to the contract may be issued to the Contractor by the Purchase Officer and all such communications and notices may be served on the Contractor either by registered posts or under certificate of posting or by ordinary post or by hand delivery at the option of such officer.

8.2.0. Quotations of rates by Contractors

- (a) The price quoted by the Contractor shall not be higher than the controlled price fixed by law for the stores or where there is no controlled price, it shall not exceed the prices or contravenes the norms for fixation of prices laid down by Government or where no such prices or norms have been fixed by the Government, it shall not exceed the price appearing in any agreement relating to price regulation by any industry in consultation with the Government.

In any case, save for special reasons stated in the tender, the price quoted shall not be higher than the lowest price charged by the Contractor for stores of the same nature, class or description to a private purchaser, domestic or foreign as well as Purchaser Governments.

- (b) If the price quoted is higher than the controlled price or where there is no controlled price, the price usually charged by the Contractor from a private Purchaser, domestic or foreign, as well as Purchaser Government for the stores of the same nature, class or description the Contractor will specifically mention this fact in his tender giving reasons for quoting higher price(s). If he fails to do so or makes any mis-statement, it shall be lawful for the Purchaser,
 - (i) to revise the price at any stage so as to bring it in conformity with the Sub-clause(a) above or
 - (ii) to terminate the contract and forfeit the Security Deposit.

8.3.0. Contract.

8.3.1. This contract is for the supply of the stores of the description, specifications and drawings, and in the quantities set forth in the contract on the date or dates specified therein. Unless otherwise specified, the stores shall be entirely brand new and of the best quality and workmanship to the satisfaction of the Inspecting Officer. The stores shall further be in all respects acceptable to the Inspecting Officer.

8.3.2 Any variation or amendment of the contract shall not be binding on the Purchaser unless and until the same is duly endorsed on the contract or incorporated in a formal instrument or in exchange of letters and signed by the parties.

8.4.0. Security Deposit/ PBG.

- 8.4.1.** Unless otherwise agreed between the Purchaser and the Contractor, the Contractor shall, within 30 days after written notices of acceptance of the tender has been posted to the Contractor, deposit with the RailTel concerned (in cash (online) or the equivalent in Government Securities or approved Banker's Guarantee Bond) a sum equal to **10%** of the total value of the stores detailed in the contract for which the tender has been accepted, as a security for the due fulfilment of the contract.
- 8.4.2.** If the Contractor, having been called upon by the Purchaser to furnish security, fails to make and to maintain a security deposit within the specified period, it shall be lawful for the Purchaser -
- (a) To recover from the Contractor the amount of such security deposit by deducting the amount from the pending bills of the Contractor under the contract or any other contract with the Purchaser or any person contracting through the Purchaser or otherwise howsoever, or
 - (b) To cancel the contract or any part thereof and to purchase or authorize the purchase of the stores at the risk and cost of the Contractor and in that event the provisions of Clause 8.6.2 shall apply as far as applicable.
- 8.4.3.** No claim shall lie against the Purchaser in respect of interest on cash deposits or securities etc.
- 8.4.4.** The Purchaser shall be entitled and it shall be lawful on his part to forfeit the said security deposit in whole or in part in the event of any default, failure or neglect on the part of the Contractor in the fulfillment or performance in all respect of the contract under reference or any other contract with the Purchaser or any part thereof to the satisfaction of the Purchaser and the Purchaser shall also be entitled to deduct from the said deposits any loss or damage which the Purchaser may suffer or be put by reason of or due to any act or other default, recoverable by the Purchaser from the Contractor in respect of the contract under reference or any other contract and in either of the events aforesaid to call upon the Contractor to maintain the said security deposit at its original limit by making further deposits, provided further that the Purchaser shall be entitled to recover any such claim from any sum then due or which at any time thereafter may become due to the Contractor under this or any other contracts with the Purchaser.
- 8.5.0. Delivery.**
- 8.5.1.** The Contractor shall as may be required by the Purchaser either deliver free or CIP (Carriage & Insurance Paid) or CIF (Cost, Insurance & Freight) at the place/places detailed in the contract, the quantities of the stores detailed therein and the stores shall be delivered not later than the date specified in the contract. The delivery will not be deemed to be complete until and unless the stores are inspected and accepted by the Inspecting Officer as provided in the contract.

- 8.5.2. The Purchaser shall not be liable to render assistance to the Contractor in securing or to arrange for or provide transport to the Contractor unless it is so specifically stated in the contract.
- 8.5.3. Notwithstanding any inspection and approval by the Inspecting Officer on the Contractor's premises, property in the stores shall not pass on to the Purchaser until the stores have been received, inspected and accepted by the consignee.
- 8.5.4. No stores shall be deliverable to the consignee on Sundays and public holidays without the written permission of the consignee.

8.6.0. Time for and Date of Delivery; the Essence of the Contract-

The time for and the date specified in the contract or as extended for the delivery of the stores shall be deemed to be of the essence of the contract and delivery must be completed not later than the date(s) so specified or extended.

8.6.1. Progressing of Deliveries- The Contractor shall allow reasonable facilities and free access to his works and records to the Inspecting Officer, Progress Officer or such other Officer as may be nominated by the Purchaser for the purpose of ascertaining the progress of the deliveries under the contract.

8.6.2. Failure and Termination: - If the Contractor fails to deliver the stores or any installment thereof within the period fixed for such delivery in the contract or as extended or at any time repudiates the contract before the expiry of such period the Purchaser may without prejudice to his other rights: -

- (a) recover from the Contractor as agreed liquidated damages and not by way of penalty a sum equivalent to Half per cent of the price of any stores (including elements of taxes, duties, freight, etc.) which the Contractor has failed to deliver within the period fixed for delivery in the contract or as extended for each week or part of a week during which the delivery of such stores may be in arrears where delivery thereof is accepted after expiry of the aforesaid period **The upper limit for recovery of liquidated damages will be 10% (Ten Percent) of Total contract value provided in the contractor**
- (b) Cancel the contract or a portion thereof and forfeit the security deposit or encash performance bank guarantee.
- (c) Cancel the contract or a portion thereof and if so desired purchase or authorize the purchase of the stores not so delivered or others of a similar description (where stores exactly complying with particulars are not, in the opinion of the Purchaser, which shall be final, readily procurable) at the risk and cost of the contractor.

It shall, however, be in the discretion of the Purchaser to collect or not the security deposit from the firm/firms on whom the contract is placed at the risk and expense of the defaulted firm.

Where action is taken under sub-clause (b) above, the contractor shall be liable for any loss which the purchaser may sustain on the account provided the purchase, or if there is an agreement to purchase, such agreement is made, in case of failure to deliver the stores within the period fixed for such delivery in the contract or extended within Nine months from the date of such failure and in case of repudiation of the contract before the expiry of the aforesaid period of delivery, within Nine months from the date of cancellation of the contract. The contractor shall not be entitled to any gain on such purchase and the manner and method of such purchase shall be in the entire discretion of the purchaser. It shall not be necessary for the purchaser to serve a notice of such purchase to the contractor.

8.6.2.1 Termination for Default –

The purchaser may, without prejudice to any other remedy for breach of contract, by written notice of default, sent to the Tenderer, terminate this contract in whole or in part.

- a) If the tenderer fails to deliver any or all of the goods within the time period(s) specified in the contract.
- b) If the tenderer fails to perform any other obligation(s) under the contract; and
- c) If the tenderer, in either of the above circumstance(s) does not remedy his failure within a period of 30 days (or such longer period as the Purchaser may authorize in writing) after receipt of the default notice from the Purchaser.
- d) In case of any of the above circumstances the RailTel shall pay the supplier for all products and services delivered till point of termination as per terms and conditions of the contract. However, any recovery and losses occurred to RailTel will be recovered from Contractor up to the value of contract.
- e) If 10% or more equipment found to be failed frequently again and again, the bidder may be barred for participating in the tender for a period of two years besides the above penalties to be imposed. Railtel keeps the right to terminate the contract in case of poor performance of quality and reliability of product supplied.

8.6.3 Consequence of Rejection- If on the stores being rejected by the Consignee at the destination, the Contractor fails to make satisfactory supplies within the stipulated period of delivery, the Purchaser shall be at liberty to: -

- (i) require the Contractor to replace the rejected stores forthwith but in any event not later than a period of 21 days from the date of rejection and the Contractor shall bear all cost of such replacement including freight, if any, on such replacing and replaced stores but without being entitled to any extra payment on that or any other account, or
- (ii) Cancel the contract and forfeit security deposit/ encash Performance Bank Guarantee.
- (iii) the purchaser authorize the purchase of quantity of the stores rejected or others of a similar description (when stores exactly complying with particulars are not in the opinion of the purchaser which shall be final, readily available) without notice

to the contractor at his risk and cost and without affecting the contractor's liability as regards the supply of any further installment due under the contract, or

8.7.0. Extension of Time for Delivery-

If such failure as aforesaid shall have arisen from any cause which the Purchaser may admit as reasonable ground for extension of time, the Purchaser shall allow such additional time as he considers to be justified by the circumstance of the case, and shall forgo the whole or such part, as he may consider reasonable, of his claim for such loss or damage as aforesaid.

8.8.0. Examination of Drawing, Specifications and Patterns-

When tenders are called for in accordance with a drawing, specification or sealed pattern the Contractor's tender to supply in accordance with such drawing, specifications or sealed pattern shall, be deemed to be an admission on his part that he has fully acquainted himself with the details thereof and, in no circumstances, will any claim on his part which may arise on account of his insufficient examination of the said drawing, specification or scaled pattern, be considered.

8.9.0. Mistakes in Drawing.

The Contractor shall be responsible for and shall pay for any alterations for the works due to any discrepancies, errors or omissions in the drawings or other particulars supplied by him whether such drawings or particulars have been approved by the Purchaser or not provided that such discrepancies, errors or omissions be not due to inaccurate information or particulars furnished to the Contractor on behalf of the Purchaser. If any dimension figure upon a drawing or plan differs from those obtained by scaling the drawing or plan, the dimensions as figured upon the drawing or plan shall be taken as correct.

8.10.0. Samples.

8.10.1 Advance Sample- Where an advance sample is required to be approved under the terms of the contract, the Contractor shall submit the sample free of cost to the Inspecting Officer within the time specified in the acceptance of tender. If the Contractor is unable to do so, he must apply immediately to the Office issuing the acceptance of tender for extension of time stating the reasons for the delay. If the Purchaser is satisfied that a reasonable ground for an extension of time exists, he may allow such additional time as he considers to be justified (and his decision shall be final) with or without alteration in the delivery period stipulated in the acceptance of tender and on such conditions as he deems fit. In the event of the failure of the Contractor to deliver the advance sample by the date specified in the acceptance of tender or any other date to which the time may be extended as aforesaid by the Purchaser or of the rejection of the sample, the Purchaser shall be entitled to cancel the contract and, if so desired, purchase or authorize the purchase of the stores, in which case the provisions of Clause 8.6.0 shall apply as far as applicable.

- 8.10.2.** Unless otherwise provided in the contract, all samples required for test shall be supplied by the Contractor free of cost. Where sample, which is supplied free, is rejected after examination and test, the same or whatever remains of the sample, after examination and test will be returned to the Contractor at his request and cost within three months of the date of such rejection at public tariff rate at Owner's risk.
- 8.10.3. Marking-** Samples submitted shall be clearly labeled with the Contractor's name and address and the acceptance of tender number.
- 8.10.4.** If the Contractor submits a sample whether with, before or after the tender, the same shall not govern the standard of supply except when it has been specifically stated so in the acceptance of tender.
- 8.10.5.** Where under the contract, the Contractor is required to submit an advance sample, any expenses incurred by the Contractor on or in connection with the production of stores in bulk, before the sample has been approved unconditionally, shall be borne by the Contractor and he shall not claim any compensation in the event of such sample being found unacceptable by the Inspecting Officer.
- 8.10.6.** The rejection of the sample by the Inspecting Authority or Inspecting Officer shall be final and binding on the Contractor.
- 8.10.7.** Where the contract does not require any advance sample to be approved, the Contractor may before proceeding with bulk manufacture or delivery of the stores, if he so desires, submit to the Inspecting Officer for inspection a sample of the stores in which case a quantity not less than one per cent of the total quantity to be supplied unless otherwise authorized by the Inspecting Officer shall be submitted. The Contractor shall not, however, be entitled to be shown any consideration or give any extension of time or claim to be exonerated from completing the delivery within the stipulated period only on the ground of delay in the approval of any such sample.
- 8.11.0. Risk of Loss or Damage to Purchaser's Property.**
- 8.11.1** All the property of the Purchaser loaned whether with or without deposit on terms and conditions to be separately agreed upon in respect of each particular contract to the Contractor in connection with the contract shall remain the property of the Purchaser, as the case may be. The Contractor shall use such property for the purpose of the execution of the contract and for no other purpose whatsoever.
- 8.11.2.** All such property shall be deemed to be in good condition when received by the Contractor unless he shall have within twenty-four hours of the receipt thereof notified the Purchase Officer to the contract. If the Contractor fails to notify any defect in the condition or quality of such property, he shall be deemed to have lost the right to do so at any subsequent stage.

- 8.11.3.** The Contractor shall return all such property and shall be responsible for the full value thereof to be assessed by the Purchaser whose decision shall be final and binding on the Contractor. The Contractor shall be liable for loss or damage to such property from whatever cause happening while such property is in the possession of or under the control of the Contractor, his servants, workmen, or agents.
- 8.11.4.** Where such property is insured by the Contractor against loss or fire at the request of the Purchaser such insurance shall be deemed to be effective by way of additional Precaution and shall not prejudice the liability of the Contractor as aforesaid.
- 8.12.0. Facilities for test and Examination-** The Contractor shall, at his own expense afford to the Inspecting Officer all reasonable facilities as may be necessary for satisfying himself, that the stores are being and/or have been manufactured in accordance with the particulars. The Inspecting Officer shall have full and free access at any time during the execution of the contract to the Contractor's work for the purpose aforesaid, and he may require the Contractor to make arrangements for inspection of the stores or any part thereof or any material at his premises or at any other place specified by the Inspecting Officer and if the Contractor has been permitted to employ the services of a Sub-Contractor, he shall in his contract with the Sub-Contractor, reserve to the Inspecting Officer a similar right.
- 8.12.1. Cost of Test-** The Contractor shall provide, without any extra charge, all materials, tools, labour and assistance of every kind which the Inspecting Officer may demand of him for any test and examination, other than special or independent test, which he shall require to make on the Contractor's or Consignee's Premises and the Contractor shall bear and pay all costs attendant thereon. If the Contractor fails to comply with the conditions aforesaid, the Inspecting Officer shall, in his sole judgment, be entitled to remove for test and examination all or any of the stores manufactured by the Contractor to any premises other than his (Contractor's) and in all such cases the Contractor shall bear the cost of transport and/or carrying out such tests elsewhere. A certificate in writing of the Inspecting Officer that the Contractor has failed to provide the facilities and the means, for test examination shall be final.
- 8.12.2. Delivery of Stores for Test-** The Contractor shall also provide and deliver for test, free of charge, at such place other than his premises as the Inspecting Officer may specify, such material or stores as he may require.
- 8.12.3. Liability for Costs of Special or Independent Test-** In the events of rejection of stores or any part thereof by the Inspecting Officer in the consequence of the sample which is removed to the laboratory or other places of test, being found on test not in conformity with the Contract and in the event of the failure of the Contractor for any reason to deliver the stores passed on test within the stipulated period, the Contractor shall, on demand pay to the Purchaser all costs incurred in the inspection and/or test. Cost of test shall be assessed at the rate charged by the laboratory to private persons for similar work.

8.12.4. Method of Testing- The Inspecting Officer shall have the right to put all the stores or materials forming part of the same or any part thereof to such tests as he may think fit and proper. The Contractor shall not be entitled to object on any ground whatsoever to the method of testing adopted by the Inspecting Officer.

8.12.5. Stores Expended in Test- Unless otherwise provided for in the contract if the test proves satisfactory and the stores or any installment thereof is accepted, the quantity of the stores or materials expended in the test will be deemed to have been taken delivery of by the Purchaser and be paid for as such.

8.12.6. Powers of Inspecting Officer- The Inspecting Officer shall have the power:-

- (i) Before any stores or part thereof are submitted for inspection to certify that they cannot be in accordance with the contract owing to the adoption of any unsatisfactory method of manufacture.
- (ii) To reject any stores submitted as not being in accordance with the particulars.
- (iii) To reject the whole of the installment tendered for inspection, if after inspection of such portion thereof as "he may in his discretion think fit", he is satisfied that the same is unsatisfactory.
- (iv) The Inspecting Officer's decision as regards the rejection shall be final and binding on the Contractor.

8.13.0. Charges for Work Necessary for Completion of the Contract-

The Contractor shall pay all charges for handling, stamping, painting, marking, protecting or preserving patent rights, drawings, templates, models and gauges and for all such measures as the Purchaser or the Inspecting Officer may deem necessary for the proper completion of the contract, though special provision therefore may not be made in the specification of drawings.

8.14.0. Responsibility of the Contractor for Executing the Contract.

8.14.1. Risk in the Stores- The Contractor shall perform the contract in all respects in accordance with the terms and conditions thereof. The stores and every constituent part thereof, whether in the possession or control of the Contractor, his agents or servants or a carrier, or in the joint possession of the Contractor, his agents or servants and the Purchaser, his agents or servants, shall remain in every respect at the risk of the Contractor, until their actual delivery to the consignee at the stipulated place or destination or, where so provided in the acceptance of tender, until their delivery to a person specified in the contract as interim consignee for the purpose of dispatch to the consignee. The Contractor shall be responsible for all loss, destruction, damage or deterioration of or to the stores from any cause whatsoever while the stores after approval by the Inspecting Officer are awaiting dispatch or delivery or are in the course of transit from the Contractor to the consignee or, as the case may be, interim consignee. The Contractor shall alone be entitled and responsible to make claims against a RailTel Administration or other carrier in respect of non-delivery, short delivery,

mis-delivery, loss, destruction, damage or deterioration of the goods entrusted to such carrier by the Contractor for transmission to the consignee or the interim consignee as the case may be.

8.14.2. Consignee's Right of Rejection – Notwithstanding any approval which the Inspecting Officer may have given in respect of the stores or any materials or other particulars or the work or workmanship involved in the performance of the contract (whether with or without any test carried out by the Contractor or the Inspecting Officer or under the direction of the Inspecting Officer) and notwithstanding delivery of the stores where so provided to the interim consignee, it shall be lawful for the consignee, on behalf of the Purchaser, to reject the stores or any part, portion or consignment thereof within a reasonable time after actual delivery thereof to him at the place or destination specified in the contract if such stores or part, portion or consignment thereof is not in all respects in conformity with the terms and conditions of the contract whether on account of any loss, deterioration or damage before dispatch or delivery or during transit or otherwise howsoever.

Note- In respect of materials pre-inspected at the firm's premises the consignee will issue rejection advice within 90 days from the date of receipt.

8.14.3. Provided that where, under the terms of the contract the stores are required to be delivered to an interim consignee for the purpose of dispatch to the consignee, the stores shall be at the Purchaser's risk after their delivery to the interim consignee, but nevertheless it shall be lawful for the consignee on behalf of the Purchaser to reject the stores or any part, portion of consignment thereof upon their actual delivery to him at the destination if they are not in all respects in conformity with the terms and conditions of contract except where they have been damaged or have deteriorated in the course of transit or otherwise after their delivery to the interim consignee.

8.14.4. The provisions contained in Clause 8.19.0 relating to the removal of stores rejected by the Inspecting Officer shall mutatis mutandis apply to stores rejected by the consignee as herein provided.

Note- In respect of stores inspected during manufacture or before delivery or dispatch at contractor's premises the consignee will issue communication of rejection within 90 days from the date of actual delivery thereof.

8.14.5. Subletting and Assignment- The Contractor shall not, save with the previous consent in writing of the Purchaser, sublet, transfer or assign the contract or any part thereof or interest therein or benefit or advantage thereof any manner whatsoever.

In the event of the Contractor's subletting or assigning this contract or any part thereof without such permission, the Purchaser shall be entitled to cancel the contract and to purchase the stores elsewhere on the Contractor's account and risk and the Contractor shall be liable for any loss or damage which the Purchaser may sustain in consequence or arising out of such purpose.

8.14.6. Changes in a Firm:-

- a) Where the Contractor is a partnership firm, a new partner shall not be introduced in the firm except with the previous consent in writing of the Purchaser, which may be granted only upon execution of a written undertaking by the new partner to perform the contract and accept all liabilities incurred by the firm under the contract prior to the date of such undertaking.
- b) On the death or retirement of any partner of the Contractor firm before complete performance of the contract, the Purchaser may, at his option, cancel the contract and in such case the Contractor shall have no claim whatsoever to compensation against the Purchaser.
- c) If the contract is not determined as provided in Sub-clause (b) above notwithstanding the retirement of a partner from the firm he shall continue to be liable under the contract for acts of the firm until a copy of the public notice given by him under Section 32 of the Partnership Act, has been sent by him to the Purchaser by registered post acknowledgement due.
- d) **Consequence of breach** - Should a partner in the Contractor firm commit a breach of Sub-clause 8.14.5 above or the Contractor should commit a breach of the conditions 8.14.6 (a) of this Sub-clause, it shall be lawful for the Purchaser to cancel the contract and purchase or authorize the purchase of the stores at the risk and cost of the Contractor and in that event the provisions of Clauses 8.5.0 and 8.6.0 as far as applicable shall apply.
- e) The decision of the Purchaser as to any matter or thing concerning or arising out of this sub-clause or on any question whether the Contractor or any partner of the Contractor firm has committed a breach of any of the conditions in this sub-clause contained shall be final and binding on the Contractor.

8.15.0. Indemnity.

8.15.1. The Contractor shall at all times indemnify the Purchaser against all claims which may be made in respect of the stores for infringement of any right protected by patent, registration of designs or trade mark. Provided always that in the event of any claim in respect of alleged breach of letters patent, registered designs or trade mark being made against the Purchaser, the Purchaser shall notify the Contractor of the same and the Contractor shall, at his own expense, either settle any such dispute or conduct any litigation that may arise there from.

8.15.2. The Contractor shall not be liable for payment of any royalty, license fee or other expenses in respect of or for making use of patents or designs with respect to which he is according to the terms of the contract, to be treated as an agent of the Government for the purpose of making use of patent or trade mark for fulfillment of the contract.

8.16.0. Packing.

- 8.16.1. The Contractor shall pack at his own cost the stores sufficiently and properly for transit by rail/road, air and/or sea as provided in the contract so as to ensure their being free from loss or damage on arrival at their destination.
- 8.16.2. Unless otherwise, provided in the contract all containers (including packing cases, boxes, tins, drums and wrappings) in which the stores are supplied by the contractor, shall be considered as non-returnable and their cost as having been included in the contract price.
- 8.16.3. If the contract provides that the containers shall be returnable, they must be marked "Returnable" and they will be returned to the Contractor as per terms of the contract.
- 8.16.4. If the contract provides that returnable containers shall be separately charged, they shall be invoiced by the Contractor at the price specified in acceptance of tender. In such cases, the Contractor shall give full credit for the invoiced amount if the containers are returned to the Contractor. Return of containers shall be made within a reasonable time and in the event of any dispute or difference arising as to whether the containers were so returned, the decision of the Purchaser thereon shall be final and binding and the Purchaser may, in his discretion award, such compensations as may in his opinion be proper for any undue delay in returning the containers.
- 8.16.5. Each bale or package delivered under the contract shall be marked by the Contractor or at his own expense. Such marking shall be distinct (all previous irrelevant marking being carefully obliterated) and shall clearly indicate the description and quantity of the stores, the name and address of the Consignee, the gross weight of the package and the name of the Contractor with a distinctive number or mark sufficient for the purpose of identification. All markings shall be carried out with such material as may be found satisfactory by the Inspecting Officer as regards quickness of drying, fastness and indelibility.
- 8.16.6. The Inspecting Officer may reject the stores if the stores are not packed/or marked as aforesaid and in case where the packing materials are separately prescribed, if such materials are not in accordance with the terms of the contract. Such rejection of the stores by the Inspecting Officer shall be final and binding on the Contractor.
- 8.16.7. Each bale or package shall contain a packing note specifying the name and address of the Contractor, the number and date of the acceptance of tender or supply order and the designation of the Purchase Officer issuing the supply order, the description of the stores and the quantity contained in such bale or package.

8.17.0 Notification of Delivery.

Notification of delivery or dispatch in regard to each and every installment shall be made to the consignee and to the indent or immediately on dispatch or delivery. The Contractor shall further supply to the consignee, or the interim

consignee, as the case may be, a packing account Quoting number of the acceptance of tender and/or supply or repeat and date of dispatch of the stores. All packages, containers, bundles and loose materials part of each and every installment shall be fully described in the packing account and full details of the contents of the packages and quantity of materials shall be given to enable the consignee to check the stores on arrival at destination. The Railway Receipt/Consignment Note or Bill of Lading, if any, shall be forwarded to the consignee by registered post immediately on the dispatch of stores. The Contractor shall bear and reimburse to the Purchaser demurrage charges, if any, paid by reason of delay on the part of the Contractor in forwarding the Railway Receipt, Consignment Note or Bill of Lading.

8.18.0. Progress Reports.

8.18.1. The Contractor shall from time-to-time, render such reports concerning the progress of the contract and/or supply of the stores in such form as may be required by the Purchaser.

8.18.2. The submission, receipt and acceptance of such reports shall not prejudice the rights of the Purchaser under the contract, nor shall operate as an estoppel against Purchaser merely by reason of the fact that he has not taken notice of or subjected to test any information contained in such report.

8.19.0. Removal of Rejected Stores.

8.19.1. On rejection of all stores submitted for inspection at a place other than the premises of the Contractor, such stores shall be removed by the Contractor at his own cost subject as hereinafter stipulated, within 21 days of the date of intimation of such rejection. If the concerned communication is addressed and posted to the Contractor at the address mentioned in the contract, it will be deemed to have been served on him at the time when such communication would be in the course of ordinary post reach the Contractor. Provided that the Inspecting Officer may call upon the Contractor to remove dangerous, infected or perishable stores within 48 hours of the receipt of such communication and the decision of the Inspecting Officer in this behalf shall be final in all respects.

Provided further that where the price or part thereof has been paid, the consignee is entitled without prejudice to his other rights to retain the rejected stores till the price paid for such stores is refunded by the Contractor save that such retention shall not in any circumstances be deemed to be acceptance of the stores or waiver of rejection thereon.

8.19.2. All rejected stores shall in any event and circumstances remain and always be at the risk of the Contractor immediately on such rejection. If such stores are not removed by the Contractor within the periods aforementioned, the Inspection Officer may remove the rejected stores and either return the same to the contractor at his risk and cost by such mode of transport as the Purchaser or Inspecting Officer may decide, or dispose of such stores at the Contractor's risk and on his account and retain such portion of the proceeds, if any from such

disposal as may necessary to recover any expense incurred in connection with such disposals (or any price refundable as a consequence of such rejection). The Purchaser shall, in addition, be entitled to recover from the Contractor ground rent/demurrage charges on the rejected stores after the expiry of the time limit mentioned above.

8.19.3. The stores that have been dispatched by road or courier and rejected after arrival at destination may be taken back by the Contractor either at the station where they were rejected or at the station from which they were sent, after refunding the price paid for such stores and other charges refundable as a consequence of such rejection. If the contract placed for delivery FOR station of dispatch, the Contractor shall pay the carriage charges on the rejected consignment at public tariff rates from the station of dispatch to the station where they are rejected. If the Contractor elects to take back the goods at the station from which they were dispatched, the goods shall in addition, be booked back to him freight to pay at public tariff rates and at owner's risk. The Contractor shall be liable to reimburse packing and incidental costs and charges incurred in such return or rejected stores in addition to other charges refundable as a consequence of rejection. The goods shall remain the property of the Contractor unless and until accepted by the Purchaser, after inspection.

8.20.0. System of Payment.

8.20.1. Unless otherwise agreed upon between the parties, payment for delivery of the stores will be made on submission of bills in the prescribed form which may be obtained from the Purchase Officer in accordance with the instructions given in the acceptance of Tender, by RTGS/NEFT as may be decided by the Purchaser.

8.20.2. Payment for the stores or for each consignment thereof will be made to the Contractor on submission of bills accompanied by required document in accordance with the mutually agreed terms & conditions, procedure has been agreed to by the Purchaser.

8.20.3. In all other contracts or in contracts where the Inspecting Officer also acts as the interim consignee or where inspection is carried on by the Consignee himself at destination and in all cases of local delivery full payment shall be made on submission of " Final 100 percent bill " supported by the Inspection Certificates and consignee's receipt as aforesaid to the Accounts Officer concerned.

8.21.0. Withholding and lien in respect of sums claimed.

8.21.1. Whenever any claim or claims for payment of a sum of money arises out of or under the contract against the Contractor, the Purchaser shall be entitled to withhold and also have a lien to retain such sum or sums in whole or in part from the security, if any, deposited by the Contractor and for the purpose aforesaid, the Purchaser shall be entitled to withhold the said cash security deposit or the security, if any, furnished as the case may be and also have a lien over the same pending finalization or adjudication of any such claim. In the event of the security being insufficient to cover the claimed amount or amounts or if no security has

been taken from the Contractor, the Purchaser shall be entitled to withhold and have lien to retain to the extent of the such claimed amount or amounts referred to supra, from any sum or sums found payable or which at any time-thereafter may become payable to the Contractor under the same contract or any other contract with the Purchaser pending finalization or adjudication of any such claim.

It is an agreed term of the contract that the sum of money or moneys so withheld or retained under the lien referred to above, by the Purchaser will be kept withheld or retained as such by the Purchaser till the claim arising out of or under the contract is determined by the Arbitrator (if the contract is governed by the arbitration clause) or by the competent court as prescribed under clause 8.24.3 hereinafter provided, as the case may be, and that the Contractor will have no claim for interest or damages whatsoever on any account in respect of such withholding or retention under the lien referred to supra and duly notified as' such to the Contractor.

8.21.2. For the purpose of Clause 8.21.1, where the Contract or is a partnership firm or a limited company, the Purchaser shall be entitled to withhold and also have a lien to retain towards such claimed amount or amounts in whole or in part from any sum found payable to any partner/limited company, as the case may be, whether in his individual capacity or otherwise.

8.21.3. Lien in respect of Claims in other Contracts

- (a) Any sum of money due and payable to the Contractor (including the security deposit returnable to him) under the contract may withhold or retain by way of lien by the Purchaser or RailTel against any claim of the Purchaser or RailTel in respect of payment of a sum of money arising out of or under any other contract made by the Contractor with the Purchaser or RailTel.
- (b) It is an agreed term of the contract that the sum of money so withheld or retained under this clause by the Purchaser or RailTel will be kept withheld or retained as such by the Purchaser or RailTel till his claim arising out of the same contract or any other contract is either mutually settled or determined by the arbitrator, if the contract is governed by the arbitration clause or by the competent court under Clause 8.24.3 hereinafter provided, as the case maybe, and that the Contractor shall have no claim for interest or damages whatsoever on this account or on any other ground in respect of any sum of money withheld or retained under this clause and duly notified as such to the Contractor.

8.22.0. Corrupt Practices

8.22.1. The contractor shall not offer or give or agree to give to any person in the employment of the purchaser or working under the orders of the Purchaser any gift or consideration of any kind as an inducement or reward for doing on for bearing to do or for having done or forborne to do any act in relation to the obtaining execution of the contract or any other contract with the Purchaser or for showing any favour or for bearing to show disfavor to any person in relation to the

contract or any other contract with the Purchaser. Any breach of the aforesaid condition by the contractor or any one employed by him or acting on his behalf (whether with or without the Knowledge of the contractor) or the commission of any offence by the contractor or by any one employed by him or acting on his behalf under Chapter IX of the Indian Penal Code, 1860 or the Prevention of Corruption Act, 1947 or any other Act enacted for the prevention of corruption by public servants shall entitle the Purchaser to cancel the contract and all or any other contracts with the contractor and to recover from the contractor the amount of any loss arising from such cancellation in accordance with the provisions of Clauses 8.5.0 and 8.6.0.

8.22.2. Any dispute or difference in respect of either the interpretation effect or application of the above condition or of the amount recoverable there under by the Purchaser from the contractor, shall be decided by the Purchaser, whose decision thereon shall be final and binding on the contractor.

8.23.0. Insolvency and Breach of Contract.

8.23.1. The Purchaser may at any time, by notice in writing summarily determine the contract without compensation to the Contractor in any of the following events, that is to say:

- (a) If the Contractor being an individual or if a firm, any partner thereof, shall at any time, be adjudged insolvent or shall have a receiving order or order for administration of his estate made against him or shall take any proceeding for composition under any Insolvency Act for the time being in force or make any conveyance or assignment of his effects or enter into any assignment or composition with his creditors or suspend payment or if the firm be dissolved under the Partnership Act, **or**
- (b) If the Contractor being a company is wound up voluntarily or by the order of a Court or a Receiver, Liquidator or Manager on behalf of the Debenture-holders is appointed or circumstances shall have arisen which entitle the Court or Debenture holders to appoint a Receiver, Liquidator or Manager, **or**
- (c) If the Contractor commits any breach of the contract not herein specifically provided for. Provided always that such determination shall not prejudice any right of action or remedy which shall have accrued or shall accrue thereafter to the Purchaser and provided also the Contractor shall be liable to pay to the Purchaser for any extra expenditure he is thereby put to and Contractor shall, under no circumstances, be entitled to any given on re-purchase.

8.24.0. Laws governing the Contract.

8.24.1. This contract shall be governed by the Laws of India for the time being in force.

8.24.2. Irrespective of the place of delivery, the place of performance or place of payment under the contract, the contract shall be deemed to have been made at the place from which the acceptance of tender has been issued.

8.24.3. Jurisdiction of courts- This Courts of the place from where the acceptance of tender has been issued shall alone have jurisdiction to decide any dispute arising out of or in respect of the contract.

8.24.4. Marking of stores- The marking of the stores must comply with the requirements of the laws relating to merchandise marks for the time being in force in India.

8.24.5. Compliance with provisions of Contract Labour (Regulation and Abolition) Act, 1970:

- 1) The Contractor shall comply with the provisions of the Contract Labour (Regulation and Abolition) Act, 1970 and the Contractor Labour (Regulation and Abolition) Central Rules, 1971, as modified from time-to-time, wherever applicable and shall also indemnify the Purchaser from and against any claims under the aforesaid Act and the Rules.
- 2) The Contractor shall obtain a valid license under the aforesaid Act as modified from time-to-time before the commencement of the contract and continue to have a valid license until the completion of the contract. Any failure to fulfill this requirement shall attract the penal provisions of the contract arising out of the resultant non-execution of the contract.
- 3) The Contractor shall pay to labour employed by him directly or through Sub-Contractors the wages as per provisions of the aforesaid Act and the Rules wherever applicable. The Contractor shall, notwithstanding the provisions of the contract to the contrary, cause to be paid the wages to labour indirectly engaged on the contract including any engaged by his Sub-Contractors in connection with the said contract, as if the labour had been immediately employed by him.
- 4) In respect of all labour directly or in directly employed in the contract for performance of the Contractor's part of the contract, the Contractor shall comply with or cause to be complied with the provisions of the aforesaid Act and the Rules wherever applicable.
- 5) In every case in which, by virtue of the provisions of the aforesaid Act or the Rules, the, Purchaser is obliged to pay any amount of wages to a workman employed by the Contractor or his Sub-Contractor in execution of the contract or to incur any expenditure in providing welfare and health amenities required to be provided under the aforesaid Act and the Rules or to incur any expenditure on account of the contingent liability of the Purchaser due to the Contractor's failure to fulfill his statutory obligations under the aforesaid Act or the Rules the Purchaser will recover from the Contractor, the amount of wages so paid or the amount of expenditure so incurred, and without prejudice to the rights of the Purchaser under Section 20, Sub-section (2) and Section 21, Sub-section (4) of the aforesaid Act, the Purchaser shall be at liberty to recover such amount or part

thereof by deducting it from the security deposit and/or from any sum due by the Purchaser to the Contractor whether under the contract or otherwise. The Purchaser shall not be bound to contest any claim made against it under Sub-section (i) of Section 20 and Sub-section (4) of Section 21 of the aforesaid Act except on the written request of the Contractor and upon his giving to the Purchaser full security for all costs for which the Purchaser might become liable in contesting such claim. The decision of the Purchaser regarding the amount actually recoverable from the Contractor as stated above, shall be final and binding on the Contractor.

8.25.0. Headings.

The headings of conditions hereto shall not affect the construction thereof.

8.26.0 Settlement of Disputes/ Arbitration

- 1) Any dispute or difference whatsoever arising between the parties out of or relating to the construction, meaning, scope, operation or effect of this contract or the validity or the breach thereof shall be settled by arbitration in accordance with the Arbitration and Conciliation Act, 1996 as amended and the award made in pursuance thereof shall be binding on the parties. The venue of such arbitration or proceedings thereof shall be at New-Delhi.
- 2) All arbitration proceedings shall be conducted in English. Recourse against any arbitral award so rendered maybe entered into court having jurisdiction or application may be made to such court for the order of enforcement as the case may be.
- 3) The Arbitral Tribunal shall consist of the Sole Arbitrator appointed by CMD/RailTel, if the value of claim is up to Rs. 10 lakh. If the value of the claim or amount under dispute is more than Rs. 10 Lakhs, the matter shall be referred to the adjudication of arbitral council. Chairman Managing Director (CMD) of RailTel shall furnish a panel of three names to the contractor, out of which, contractor will recommend one name to be his nominee and then CMD/RailTel shall appoint one name as RailTel's nominee and these two arbitrators with mutual consent shall appoint a third arbitrator who shall act as the deciding arbitrator in terms of Arbitration and Conciliation Act. The award of the sole arbitrator or the Arbitral council, as the case may be, shall be final and binding on both the parties. Each of the parties agree that notwithstanding that the matter may be referred to Arbitrator as provided herein, the parties shall nevertheless pending the resolution of the Controversy or disagreement, continue to fulfill their obligation under this Agreement so far as they are reasonably able to do so.

8.27.0. Inspection & Rejection: -

Where under a contract the price payable is fixed on FOR station of dispatch basis, the Contractor shall, if the consignee rejects the stores at destination be liable in addition to his other liabilities, to reimburse to the Purchaser the freight paid by the Purchaser.

8.27.1 Notification of Result of inspection- Unless otherwise provided in the specification of schedule, the examination of the stores will be made as soon as practicable after the same have been submitted for inspection and the result of the examination will be notified to the Contractor.

8.27.2 Inspection Notes-On the stores being found acceptable by the inspecting Officer he shall furnish the Contractor with necessary copies of Inspection Notes duly completed, for being attached to the Contractor's bill in support thereof.

8.28.0 Warranty/Guarantee

8.28.1 The supplier shall warrant that material to be supplied shall be new and free from all defects and faults in material, workmanship, manufacture and shall be of the highest grade consistent with the established and generally accepted standards of materials for the type ordered and shall perform in full conformity with the specifications and drawings. The supplier shall be responsible for any defects (with respect to the specification of the material) that may develop subsequently under the conditions provided in the contract under proper use, arising out of faulty materials, design or workmanship such as corrosion, inadequate quantity of material to meet equipment requirements, deficiencies in design and/ or otherwise and shall remedy such defects at his own cost when called upon to do so by the Purchaser who shall state in writing in what respect the stores are faulty.

8.28.2 If it becomes necessary for the contractor to replace or renew any defective portion/portions of the supplies under this clause, the provisions of the clause shall apply to the portion/portions of the equipment/ material so replaced or renewed or until the end of the above-mentioned period, whichever may be later. If any defect is not remedied within a reasonable time, the Purchaser may proceed to do the work at the contractor's risk and expenses, but without prejudice to any other rights which the Purchaser may have against the contractor in respect of such defects.

8.28.3 Replacement under warranty clause shall be made by the contractor free of all charges at site including freight, insurance and other incidental charges.

8.28.4 The Contractor/Seller hereby covenants that it is a condition of the contract that all goods/stores/articles furnished to the Purchaser under this contract shall be of the highest grade free of all defects and faults and of the best materials, quality, manufacture and workmanship throughout and consistent with the established and generally accepted standards for materials of the type ordered and in full conformity with the contract specification, drawing or sample, if any and shall, if operable, operate properly.

8.28.5 The Contractor also guarantees that the said goods/stores/articles would continue to conform to the description and quality as aforesaid, for a period as mentioned in **BID data sheet** after their delivery or after a period as mentioned in BID data sheet from the date of placement in service whichever shall be sooner, and this warranty shall survive notwithstanding the fact that the

goods/stores/articles may have been inspected, accepted and payment thereof made by the Purchaser.

- 8.28.6 If during the aforesaid period, the said goods/stores/articles be discovered not to conform to the description and quality aforesaid or have deteriorated, otherwise that by fair wear and tear the decision of the Purchaser in that behalf being final and conclusive that the Purchaser will be entitled to reject the said goods/stores/articles or such portions thereof as may be discovered not to conform to the said description and quality. On such rejection, the goods/stores/articles will be at the Seller's risk. If the Contractor/Seller so desires, the rejected goods may be taken over by him or his agents for disposal such manner as he may deem fit within a period of 3 months from the date of such rejection. At the expiry of the period, no claim whatsoever shall lie against the **Purchaser** in respect of the said goods/stores/articles, which may be disposed of by the Purchaser in such manner as he thinks fit. Without prejudice to the generality of the foregoing, all the provisions in the Standard Conditions of Contract relating to the 'rejection of stores' and 'failure' and 'termination' and Clause 8.27.0- 2 above shall apply.
- 8.28.7 The Contractor/Seller shall, if required, replace the goods or such portion thereof as have been rejected by the Purchaser, free of cost, at the ultimate destination, or at the option of the Purchaser, the Contractor/Seller shall pay to the Purchaser, the value thereof at the contract price and such other expenditure and damage as may arise by reason of the breach of the conditions hereinbefore specified. Nothing herein contained shall prejudice any other right of the Purchaser in that behalf under this contract or otherwise.

8.29.0. Inspection at the Fag end of the Delivery Period-

In cases where only a portion of the stores ordered is tendered for inspection at the Fag end of the delivery period and also in cases where inspection is not completed in respect of the portion of the stores tendered for inspection during the delivery period, the Purchaser reserves the right to cancel the balance quantity not tendered for inspection within the delivery period fixed in the contractor the risk and expense of the Contractor without any further reference to him. If the stores tendered for inspection during or at the fag end of the delivery period are not found acceptable after carrying out the inspection, the purchaser is entitled to cancel the contract in respect of the same at the risk and expense of the contractor. If, however, the stores tendered for inspection are found acceptable, the Purchaser may grant an extension of the delivery period subject to the following conditions:

- (a) The Purchaser has the right to recover from the contractor under the provision of clause 8.6.2 (a) of Standard Conditions of Contract liquidated damages on the stores which the Contractor has failed to deliver within the period fixed for delivery.
- (b) That no increase in price on account of any statutory increase in or fresh imposition of Customs Duty, Excise Duty, Sales Tax on account of Foreign

Exchange variation or on account of any other tax or duty leviable in respect of stores specified in the contract which takes place after the date of the delivery period stipulated in the contract shall be admissible on such of the said stores as are delivered after the date of the delivery stipulated in the contract.

- (c) That notwithstanding any stipulation in the contract for increase in price on any other ground no such increase which takes place after the date of the delivery stipulated in the contract shall be admissible on such of the said stores as are delivered after the expiry of the delivery period stipulated in the contract.
- (d) But nevertheless, the Purchaser shall be entitled to the benefit fit of any decrease in price on account of reduction in or remission of Custom Duty, Sales Tax or on account of Foreign Exchange variation or on account of any other Tax or Duty or on other ground as stipulated in the price variation, clause which takes place after the expiry of the date of delivery period stipulated in the contract.

8.29.1. The Contractor shall not dispatch the Stores till such time as an extension in terms of para 8.29.0 (a) to (d) above is granted by the Purchaser and accepted by the Contractor. If the stores are dispatched by the Contractor before an extension letter as aforesaid is issued by the Purchaser and the same are accepted by the Consignee, the acceptance of the stores shall be deemed to be subject to the conditions (a) to (d) mentioned in the paragraph 8.29.0 above.

8.29.2. In case where the some or the entire quantity has not been tendered for inspection with in the delivery period stipulated in the contract and the Purchaser chooses to grant an extension of the delivery period the same would be subject to conditions (a) to (d) mentioned in the paragraph 8.29.0 above.

8.30.0. Additional Conditions: -

These (special) conditions wherever they differ from the Invitation to Tender and Instruction to Tenderers over ride the latter.

In addition to those conditions, the following special conditions shall govern the Rate/Running contract and all supply orders placed under it: -

Additional (Special Conditions):

1. **Purpose of Contract:** The contract, which shall be deemed to be a Rate /Running contract is intended for the supply of the Stores of the descriptions set forth in the Scheduled to Tender during the period therein specified.
2. **Period of Contract:** Unless otherwise indicated in the schedule, the period of contract shall be one year from the date of acceptance of offer.
3. The Purchaser may authorize any officer (who shall hereinafter be called Direct Demanding Officer) at any time during the period of the contract, to place orders, called supply orders direct on the Contractor. The Contractor shall deliver or dispatch the full quantity of the stores so ordered by the Purchaser or the Direct

Demanding Officer within the period specified in the contract or as mutually agreed to.

4. **Number or quantity contracted for** – subject as hereinafter mentioned, no guarantee can be given as to the number or quantity of the stores which will be ordered during the period of the rate contract which is only in the nature of a standing offer from the Contractor. But the purchaser undertakes to order from the contractor all stores as detailed in the contract which he requires to purchase during the period of the contract except that he reserves the right (1) of submitting to competition any supply of Stores included in the contract, (2) of placing rate contracts simultaneously or at any time during its period with one or more contractors as he may think fit, and (3) of obtaining from any source any stores referred to in the contract to meet any emergency if the Purchaser (whose decision shall be final) is satisfied that the contractor is not in a position to supply specific quantities within the period in which supplies are required.
5. **Minimum/maximum order value** - The value of any single supply order shall not be less than one unit and not more than the estimated quantity subject to provision of the contract.
6. **Delay or default** in supplies either in part or in full entitles the Purchaser, in addition to other remedies, not to order any further quantities on the contractor even up to any quantities indicated in the contract.
7. **Fall Clause:**
 - I. The price charged for the stores under the contract by the Contractor shall in no event exceed the lowest price at which the contractor sells the Stores or offers to sell stores of identical description to any person / organizations including the purchaser or any Department of the Central Government or any Department of a State Government or any statutory undertaking of the Central or State Government, as the case may be during the period till the performance of all Supply orders placed during the currency of the Advance Purchase Order/rate contract is completed.
 - II. If at any time, during the said period, the contractor reduces the sales price, sells or offers to sell such Stores to any person / organization including the purchaser or any Department of central Government or any Department of the State Government or any statutory undertaking of the Central or State Government as the case may be, at a price lower than the price chargeable under the contract, he shall forthwith notify such reduction in sales price to the Purchaser and the price payable under the contract for the Stores supplied after the date of coming into force of such reduction shall stand correspondingly reduced, the above stipulation will, however, not apply to:
 - (a) Export/Deemed Exports by the contractor,
 - (b) Sale of goods such as drugs which have expiry dates, and
 - III. The contractor shall furnish the following Certificate to the bill paying officer along with each bill for payment of supplies made against the contract:

“I/We certify that there has been no reduction in sale price of the Stores of description identical to the stores supplied under the contract herein and such stores have not been offered & sold by me/us to any person/organization including the purchase or any Department of Central Government or any Department of State Government or any statutory Undertaking of the Central or State Government as the case may be, up to the date of bill/ the date of completion of supplies against all supply orders placed during the currency of the contract at a price lower than the price charged to the purchaser under the contract except for quantity of Stores categorized under sub-clauses (a), (b), of sub-para II above, details of which are as follows: ”.

रेलटेल
RAILTEL

Chapter 9

PROFORMA FOR PERFORMANCE BANK GUARANTEE

Annexure-I

PERFORMANCE BANK GAURANTEE BOND
 (On Stamp Paper of Rs. One Hundred)
 (To be used by approved Scheduled Banks)

1. In consideration of the RailTel Corporation of India Limited, 6th Floor, Delhi IT Park, Shastri Park, Delhi-110053 (Herein after called RailTel) having agreed to exempt(Hereinafter called “the said Contractor(s)”) from the demand, under the terms and conditions of an Agreement No.....dated.....made between.....and..... for (hereinafter called “ the said Agreement”) of security deposit for the due fulfillment by the said Contractor (s) of the terms and conditions contained in the said Agreement, on production of a Bank Guarantee for Rs.(Rs only). We (indicate the name of the Bank) hereinafter referred to as “the Bank”) at the request of Contractor(s) do hereby undertake to pay the RailTel an amount not exceeding Rs. against any loss or damage caused to or suffered or would be caused to or suffered by the RailTel by reason of any breach by the said Contractor(s) of any of the terms or conditions contained in the said Agreement.
2. We, Bank and our local branch at New Delhi (indicate detail address of local New Delhi branch with code no.) do hereby undertake to pay the amounts due and payable under this Guarantee without any demur, merely on demand from the RailTel stating that the amount is claimed is due by way of loss or damage caused to or would be caused to or suffered by the RailTel by reason of breach by the said Contractor(s) of any of terms or conditions contained in the said Agreement or by reason of the Contractor(s) failure to perform the said Agreement. Any such demand made on the Bank shall be conclusive as regards the amount due and payable by the Bank under this guarantee. However, our liability under this guarantee shall be restricted to an amount not exceeding Rs
3. We, bank undertake to pay to the RailTel any money so demanded notwithstanding any dispute or disputes raised by the Contractor(s) / Tenderer(s) in any suit or proceedings pending before any court or Tribunal relating thereto our liability under this present being, absolute and unequivocal. The payment so made by us under this Bond shall be a valid discharge of our liability for payment there under and the Contractor(s) / Tenderer(s) shall have no claim against us for making such payment.
4. We, Bank further agree that the Guarantee herein contained shall remain in full force and effect during the period that would be taken for the performance of the said Agreement and that it shall continue to be enforceable till all the dues of the RailTel under or by virtue of the said Agreement have been fully paid and its claims satisfied or discharged or till RailTel certifies that the terms and conditions of the said Agreement have been fully and properly carried out by the said Contractor(s) and accordingly discharges this Guarantee. Unless a demand or claim under the Guarantee is made on us in writing on or before the We shall be discharged from all liability under this Guarantee thereafter.
5. We,..... (indicate the name of Bank) further agree with the RailTel that the RailTel shall have the fullest liberty without our consent and without affecting in any manner our obligations hereunder to vary any of the terms and conditions of the Agreement or to extend time of to postpone for any time or from time to time any of the powers exercisable by the RailTel against the said contractor(s) and to forbear or enforce any of the terms and conditions relating to the said Agreement and we shall not be relieved from our liability by reason of any such variation, or extension to the said Contractor(s) or for any forbearance, act or omission on the part of RailTel or any indulgence by the RailTel to the said Contractor(s) or by any such matter or thing

Chapter 10

IPS Drawing

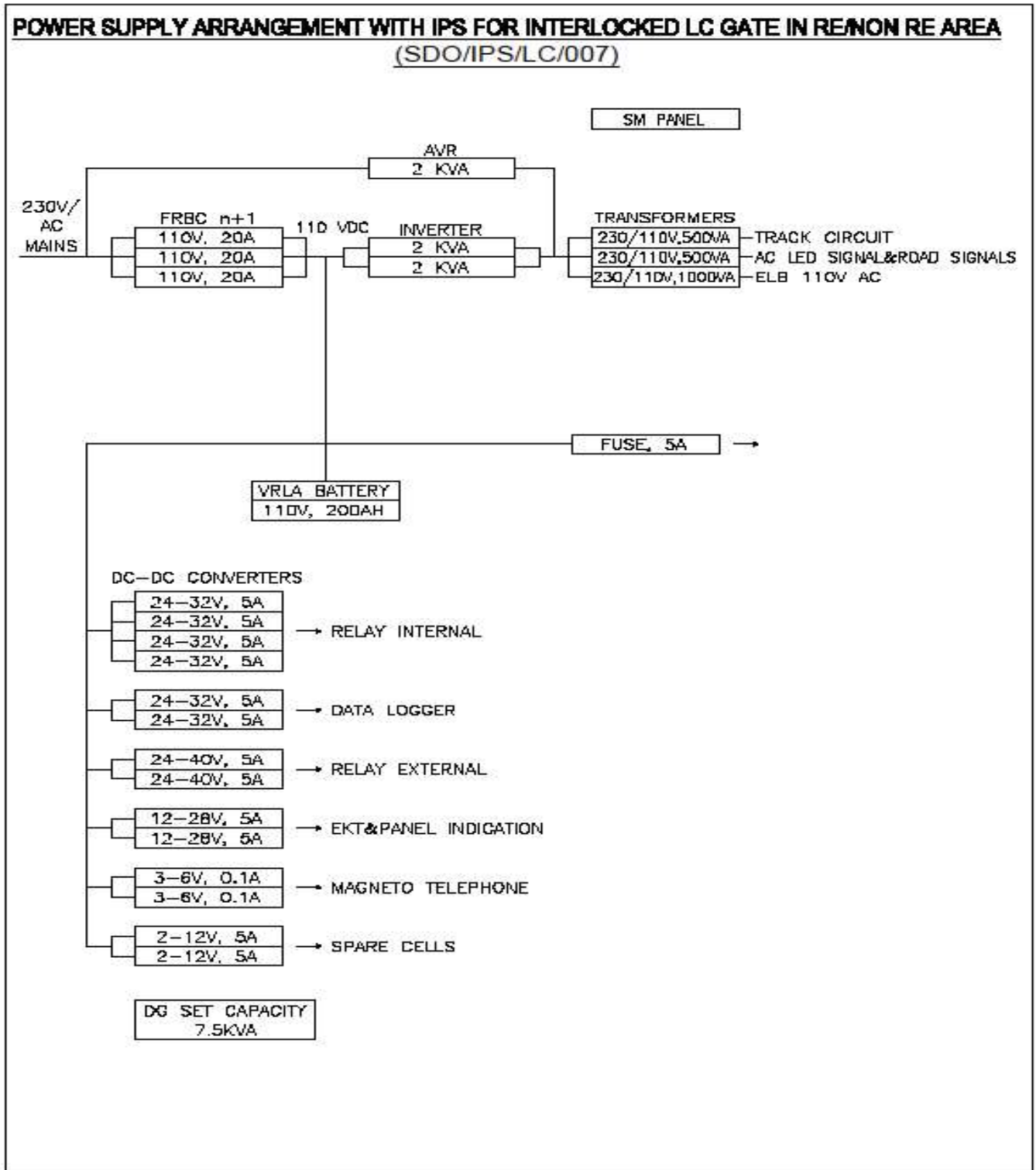

Chapter 11

Check List

| SN | Have you submitted the following documents? | Submitted /complied or Not | Page No/ ref no. of Offer |
|----|--|----------------------------|---------------------------|
| 1 | Cost of tender document | | |
| 2 | Power of Attorney | | |
| 3 | Downloaded tender document digitally signed. | | |
| 4 | Bid Security/EMD submission | | |
| 5 | Documents required as per clause no. 3.3 of eligibility criteria of chapter 3 | | |
| 6 | Performance statement including Copies of Purchase Orders & Inspection certificates as per clause 6.10 (i) Chapter 6. | | |
| 7 | Compliance statement for acceptance of Technical specification (Chapter 4) & Instructions and Tender Conditions (Chapter 3,6,7,8). | | |
| 8 | Deviation Statement, if any, (Chapter wise and Clause wise) from Technical Specification & Tender conditions. | | |

*****END OF THE DOCUMENT *****

रेलटेल
RAILTEL