



RAILTEL CORPORATION OF INDIA LIMITED (RCIL)

ELECTRONICS TENDER DOCUMENT (OPEN TENDER- SINGLE PACKET)

“Construction of Eight number Gate Goomty at Chinna (L-Xing 33) in VKA-CHN Section; Gurudaspur (L-Xing 53 & 54), Dhariwal (L-Xing 38) in DHW-SRM Section; Nurmahal (L-Xing 18), Bilga (L-Xing 11 & 12); Nakodar (L-Xing 36) in LNK -PHR Section.”.

TENDER NO.

TENDER NO. RCIL-SIG-GOOMTY_23-24-15, Dt. 16.08.2023

TENDER DOCUMENT

S.No.	INDEX	Page No.
1	TOP SHEET	3-13
2	TENDER NOTICE	14-26
3	OFFER LETTER	27-29
4	VOLUME-I SPECIAL TENDER CONDITIONS AND INSTRUCTION TO TENDERERS ANNEXURE- A to V and AA to AF	30-157
5	VOLUME –II GENERAL CONDITIONS OF CONTRACT	158-184
6	VOLUME- III TECHNICAL SPECIFICATION & INSTALLATION PRACTICES AND SCOPE OF WORK	185-200
7	VOLUME – IV Schedule of Work	201
8	VOLUME – V DRAWING OF SIGNAL BUILDING	202-209



TENDER DOCUMENT
RAILTEL CORPORATION OF INDIA LIMITED
(TOP SHEET)

(A) Details to be filled in by RCIL:

Mode of Tender	E-Tender (Single Packet)
Tender Notice No.	TENDER NO. RCIL-SIG-GOOMTY_23-24-15, Dt. 16.08.2023
Full name of work	“Construction of Eight number Gate Goomty at Chinna (L-Xing 33) in VKA-CHN Section; Gurudaspur (L-Xing 53 & 54), Dhariwal (L-Xing 38) in DHW-SRM Section; Nurmahal (L-Xing 18), Bilga (L-Xing 11 & 12); Nakodar (L-Xing 36) in LNK -PHR Section”.
Approx. cost	Rs. 26,40,648.80 /-
Completion period	06 (Six) months
Earnest money amount*	Rs. 53,000/-
Sale/availability of tender document on Rly. Website	Tender documents will be available on IREPS web site i.e. www.ireps.gov.in from 16.08.2023 to 05.09.2023 upto 15:00 hrs.
Last date/Time of upload of tenders	Tender will be closed on 05.09.2023 at 15:00 hours.
Date and time of opening of tender	On dated 05.09.2023 at 15:30 hrs.

Note * Eligible MSEs are exempted from cost of tender documents and EMD. No other exemption will be given. Submission of Udyam Registration is mandatory to avail this exception.

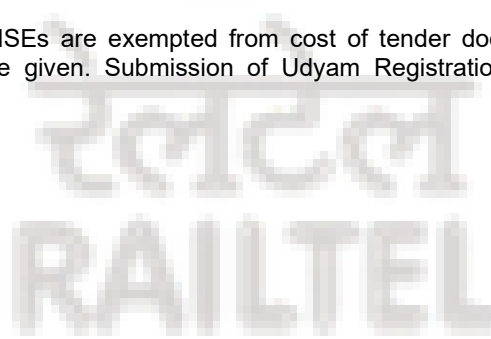

(B) Details to be filled in by tenderer while uploading their offer:

1	Constitution of the firm/ Concern (Tick as applicable)	Sole Proprietorship/ Partnership Firm / Company/ Society/LLP/HUF
2	Full name of Sole Proprietorship/ Partnership firm/ Company/ JV/ Society/LLP/HUF(as the case may be)	
3	Year of formation/ incorporation	
4	PAN NO.	
5	Registered Office Address	
6	Address on which correspondence regarding this tender should be done	
7	Names of the Proprietor/ Partners etc	
8	Contact No and e-mail id of authorized person under whose digital signature key tender document will be signed/uploaded on behalf of the tendering firm	
9	GSTIN	

Note:

- i) Special attention of tenderers is drawn to clause 2.4.1 of “Special tender condition & instruction to tenderers”, tenderer must upload, the documents mentioned therein pertaining to constitution of firm/ concern.
- ii) Special attention of tenderers is drawn to **clause 2.3 of “special tender condition & instruction to tenderers”** and **Annexure-M**, they should up load the requisite documents pertaining to their technical & financial eligibility.

Signature of the tenderer

Name of signatory_____

(C) Check List of documents to be uploaded by the tenderer(s) while submitting their offer.

Tenderer must upload following documents along with their offer

1	Cost of tender document (NIL in case of E-tender mode)
2	Earnest money amount: As per NIT
3	All requisite documents/credentials mentioned in clause 2.3 of “ <i>Special Tender Conditions and Instructions to tenderers</i> ” pertaining to his/their technical and financial eligibility. (As applicable)
4	All requisite documents mentioned in clause 2.4 of “ <i>Special Tender Conditions and instruction to tenderers</i> ” pertaining to constitution of firm/concern. (As applicable).
5	Tenderers are compulsorily required to upload certificate as per Annexure – M as stipulated in 2.2.6 of “ <i>Special Tender Conditions and instruction to tenderers</i> ” without which the offer will be considered incomplete and will be rejected summarily. (Ref: RB letter No. 2022/CE-I/CT/GCC-2022/Policy dated 27.04.2022)
6	Applicable for tender value more than Rs 20 crore. (Not Applicable) Tenderer(s) are compulsorily required to upload detail statement of works being executed/in hand on prescribed format as per Annexure-H & maximum value of contractual payment received in any one year in last three years & current financial year upto the date of inviting of tender as per Annexure-N as stipulated in Clause No. 2.3.2(A)(xiv) of “ <i>Special Tender Condition and Instructions to Tenderer(s)</i> ” without which the offer will be considered as incomplete and will be rejected summarily.
7	Tenderers are required to upload requisite details in prescribed Performa of Annexure - C to G,I, J& L without which the offer is liable to be rejected.
Note	<p>i) After opening of tender, any document/credential pertaining to technical, financial eligibility and available Bid Capacity constitution of firm etc. shall neither be asked nor be entertained/considered under any circumstances and no claim or representation whatsoever from the tenderer in this regard shall be entertained. Scanned copy of the documents, uploaded by the tenderer shall be clear & readable. However, RCIL reserves the right to ask for any clarification on the documents/credentials already submitted by the tenderer along with the offer.</p> <p>ii) Tenderer may have to produce the original Documents in physical form at short notice whenever asked by RCIL at any stage of tender evaluation process or even after finalization of tender.</p> <p>iii) In E-tender, all submissions of documents are to be uploaded on web-site. There may be last minute hic-cups and delay in uploading the Documents and payment of Earnest Money etc. Tenderer’s/Prospective bidders are advised to upload their offer well in time. RCIL will not be responsible for any delay/non submission of offer due to any reason whatsoever.</p> <p>iv) Annexure Q-Mandatory undertaking Regarding Employment/ Partnership of Retired Railways/RCIL Employees.</p> <p>v) Annexure – S Mandatory certificate regarding instructions for bidders from a country which shares a land border with India.</p> <p>vi) In case of tender value more Rs. 20 crore, (Not Applicable) Tenderer may please note that offers received without requisite Annexure-H & N as mentioned above, will be considered as incomplete & invalid tender and for which contractor shall have no claim on RCIL .</p>

(D) CHECK LIST OF DOCUMENTS ATTACHED WITH THE OFFER

S.No	Document/ Detail	Required in the form	Attached	
			Yes	No
	Constitution of Firm documents (as required in terms of Clause 2.4 of the tender document)			
1	In case of Sole Proprietorship Concern	(Undertaking as per Annexure O-1) Undertaking may be given. If not given As per para 14(iii) of GCC-2022, If it is NOT mentioned in the submitted tender that tender is being submitted on behalf of a Sole Proprietorship firm/Partnership firm/Joint Venture/Registered Company etc., then the tender shall be treated as having been submitted by the individual who has signed the tender.		
2	In case of a "Partnership Firm/Concern"	(i) Notary certified copy of the Partnership Deed. (ii) Document(s) in support of Registration of firm with Registrar/Sub-Registrar of firms which includes Certificate of registration and register of firm (Form No. may vary from State to State) (as applicable) etc. issued by Registrar of firms. (iii) Notarised /Registered Power of Attorney /in favour of the individual signing the tender document authorized by all the partners to act on behalf of the firm and create liability against the Firm. (Standard Performa as per Annexure O-2 is enclosed for guidance)		
		(iv) An undertaking by all partners of the partnership firm that they are not blacklisted or debarred by RCIL/Railway or any other Ministry / Department of the Govt. of India from participation in tenders / contracts as on the date of opening of bids, either in their individual		

		<p>capacity or in any firm in which they were / are partners. Concealment / wrong information in regard to above shall make the contract liable for determination under Clause 62 of the General Conditions of Contract.</p> <p>Note: Authorisation given in POA only will be considered irrespective of any authorization that may have given in Partnership Deed. In case of non-submission of POA or invalid POA, offer is liable to be rejected.</p>		
3	In case of a "JV Firm" (Not Applicable for this tender)	(i) A copy of Memorandum of Understanding (MoU) duly executed by the JV members on a stamp paper, shall be submitted by the JV alongwith the tender (Standard Performa as per Annexure – K-I). The complete details of the members of the JV, their share and responsibility in the JV etc. particularly with reference to financial, technical and other obligations shall be furnished in the MoU.		
		(ii) Power of Attorney/authorization duly Notarised by all JV constituents, in favour of the individual under whose digital signature key the tender document shall be uploaded on behalf of JV for signing the tender document on behalf of the JV(Standard Performa as per Annexure O-3)		
3 (a)	In case one or more of the members of the JV Firm is/are Partnership Firm(s), following documents shall be submitted:	(i) Notary certified copy of the Partnership Deed. Document(s) in support of registration of firm with registrar/Sub-Registrar of firms viz. Certificate of registration and Register of firm (Form No. may vary from State to State) etc. issued by registrar of firms.		
		(ii) A copy of consent of all the partners or individual authorized by partnership firm, to enter into the Joint Venture Agreement on a stamp paper, (Standard Performa as per Annexure O-4)		
		(iii) A copy of Power of Attorney (duly notarized/registered) in favour of the individual to sign the MOU/JV Agreement on behalf of the		

		<p>partnership firm and create liability against the firm. (Standard Performa as per Annexure O-5)</p> <p>Note: Authorisation given in POA only will be considered irrespective of any authorization that may have given in Partnership Deed. In case of non-submission of POA or invalid POA, offer is liable to be rejected.</p>		
3(b)	In case one or more of the members of the JV Firm is/are Proprietary Firm or HUF, following documents shall be submitted:	A copy of notarized affidavit on Stamp Paper declaring that he who is signing the affidavit on behalf of HUF is in the position of 'Karta' of Hindu Undivided (HUF) and he has the authority, power and consent given by other members to act on behalf of HUF. (Standard Affidavit as per Annexure O-6).		
3(c)	In case one or more members of JV is/are Limited Companies, the following documents shall be submitted:	(i) A copy of resolutions of the Directors of the Company, permitting the company to enter into a JV agreement, (Standard Performa as per Annexure O-7)		
		(ii) Copy of Memorandum and Articles of Association of the Company.		
		(iii) Copy of certificate of incorporation.		
		(iv) A copy of Authorization/copy of Power of Attorney issued by the Company (backed by the resolution of Board of Directors) in favour of the individual to sign the tender, sign MOU/JV Agreement on behalf of the company and create liability against the company (Standard Performa as per Annexure O-8).		
3(d)	In case one or more members of JV is/are LLP firm, the following documents shall be submitted/uploaded	(i) A notarised copy of certificate of incorporation and LLP agreement. (ii) A notarised copy of resolution of the partners of LLP, permitting the LLP to enter into a JV agreement, authorising one of the partners of LLP to sign JV MOU/agreement and such other documents required to be signed on behalf of the LLP and to create liability against the LLP and/or to do any other act on behalf of LLP (Standard proforma as per Annexure O-13)		

		(iii) A copy of authorisation/copy of power of attorney issued by the LLP (backed by resolution of partners) in favour of individual to sign the tender, sign MOU/JV agreement on behalf of the LLP and create liability against the LLP (Standard proforma as per Annexure O-14)		
	Note:- All the Members of JV shall certify that they are not blacklisted or debarred by RCIL/RAILWAYS or any other Ministry / Department of the Govt. of India from participation in tenders/contract on the date of opening of bids either in their individual capacity or as a member of the JV in which they were/are members.			
4	In case of a "Company"	(i) Copies of the AOA / MOA (Article of Association / Memorandum of Association) of the Company (ii) A copy of certificate of incorporation. (iii) A copy of Authorization/Power of Attorney issued by the Company (backed by the resolution of Board of Directors) in favour of the individual to sign the tender on behalf of the company and create liability against the company (Standard Performa as per Annexure O-9, 10). (iv) An Undertaking that the company is not black listed or debarred by RCIL/Railway or any other Ministry/Department of Govt. of India from participation in tender on the date of opening of bids, either in individual capacity or as a member of the partnership firm or JV in which the company was/is a partner/member. Concealment/wrong information in regard to above shall make the contract liable for determination under clause 62 of the General Conditions of contract.		
5	In case of a Registered Society & Registered Trust	(i) copy of the certificate of registration;		

		(ii) copy of Deed of formation; and		
		(iii) Notarised copy of Power of Attorney in favour of the individual to sign the tender documents and create liability against the Society/Trust.		
6	In case of LLP	<p>(i) A copy of LLP Agreement,</p> <p>(ii) A copy of Certificate of Incorporation; and</p> <p>(iii) A copy of Power of Attorney/Authorization issued by the LLP in favour of the individual to sign the tender on behalf of the LLP and create liability against the LLP (Standard proforma as per Annexure O-11 & O-12).</p> <p>(iv) An Undertaking that the LLP is not black listed or debarred by RCIL/Railway or any other Ministry/Department of Govt. of India from participation in tender on the date of opening of bids, either in individual capacity or as a member of JV in which the LLP was/is a member. Concealment/wrong information in regard to above shall make the contract liable for determination under clause 62 of the General Conditions of contract.</p>		
6 (A)	In case of HUF	<p>(i) A copy of notarized affidavit on Stamp Paper declaring that he who is submitting the tender on behalf of HUF is in the position of 'Karta' of Hindu Undivided family (HUF) and he has the authority, power and consent given by other members to act on behalf of HUF (Standard proforma as per Annexure O-15).</p> <p>(ii) An undertaking that the HUF is not blacklisted or debarred by RCIL / Railway / or any other Ministry / Department of Govt. of India from participation in tender on the date of opening of bids, either in individual capacity or as a member of the partnership firm or JV in which HUF was / is a partner/member. Concealment / wrong information in regard to above shall make the contract liable for determination under Clause 62 of the General Conditions of Contract.</p>		
Other important documents				

7	<u>Technical Eligibility Criteria:-</u>	Completion/Performance Certificate in support of 30%/40%/60% (as the case may be) for similar nature of work as per clause 2.3.2.A(v) of tender document.		
8	<u>Financial Eligibility Criteria:-</u>	Contractual payment received as per Annexure-I and as per clause 2.3.2 (vi) of Tender Document.		
9	Annexure-C	Declaration form regarding site etc.		
10	Annexure-D	Declaration regarding constitution of firm		
11	Annexure-E	Plant and Machinery		
12	Annexure-F	Engineers/Personnel		
13	Annexure-G	Works executed during last 7 years ending last day of the month previous to the one in which tender is invited		
14	Annexure-H	Works in Hand - in support of Bid Capacity (Mandatorily for tender value more than Rs. 20 crore) Not Applicable		
15	Annexure-I	<p>Detail of Contractual Payment received in previous three financial years and the current financial year as per Annexure-I, duly certified by Chartered Accountant. Contractual payment received should be based on Audited Balance Sheets or Form 16A /26AS generated through TRACES of IT or certificate from concerned Department / Client.</p> <p>Note:</p> <p>(i) Client certificate from other than Govt. Organisation should be duly supported by Form 16A/26AS generated through TRACES of IT Department.</p> <p>(ii) The Audited Balance Sheet or Form 16A /26AS from IT TRACES or Certificates from concerned Department / Client as referred for contractual payments received should be submitted alongwith the tender failing which payment received shall not be considered.</p> <p>(iii) In case the figure of contractual payment is not directly available in Audited Balance Sheet, the CA should obtain this figure from the Audited Account based on which the Balance Sheet has been prepared.</p>		
16	Annexure-J	Bank Detail/RTGS mandate form		
17	Annexure-L	Performa of Completion Certificate		
18	Annexure- N	Contractual payment received in last three years - in support of Bid Capacity (Mandatorily for tender value more than Rs.		

		<p>20 crore) (Not Applicable) as per Annexure-N, duly certified by Chartered Accountant. Contractual payment received should be based on Audited Balance Sheets or Form 16A /26AS generated through TRACES of IT or certificate from concerned Department / Client.</p> <p>Note:</p> <p>(i) Client certificate from other than Govt. Organisation should be duly supported by Form 16A/26AS generated through TRACES of IT Department.</p> <p>(ii) The Audited Balance Sheet or Form 16A /26AS from IT TRACES or Certificates from concerned Department / Client as referred for contractual payments received should be submitted alongwith the tender failing which payment received shall not be considered.</p> <p>(iii) In case the figure of contractual payment is not directly available in Audited Balance Sheet, the CA should obtain this figure from the Audited Account based on which the Balance Sheet has been prepared</p>		
19	Annexure M	Mandatory certificate to be submitted by tenderer alongwith the tender documents		
20	Annexure Q	Mandatory undertaking Regarding Employment/ Partnership of Retired RCIL/Railway Employees		
21	Attested copy of Ballast Test Report	Not applicable to this tender.		
22	Annexure – S	Mandatory certificate to be submitted by tenderer alongwith the tender documents.		
23	Annexure – T/T1	Bid Security Declaration in lieu of EMD (Mandatory certificate to be submitted): Not applicable: DELETED		
24	Annexure – K-3 & K-4	If tender submitted on behalf of Partnership Firm, relevant Annexures K-3 and K-4 as Declaration to be submitted by the tenderer alongwith tender document.		
25	Annexure-IV Vol. II	Mandatory authorization by OEM/RDSO approved Indian partner of EI. To be submitted with Technical bid (for EI tenders only) (Not Applicable)		
26	Annexure IV-A(1)-A(5) Vol. II	Mandatory Card/modules & other accessories detail of EI system being offered, duly authorized by OEM/RDSO approved Indian partner. To be submitted with Financial bid (for EI tenders only) (Not Applicable)		
27	Annexure-U (Not applicable for this tender)	Mandatory Integrity pact to be submitted by tenderer (in 2 copies) on a non-judicial stamp paper of Rs.100/- duly signed by the person signing the bid.		

E. PRECAUTIONS TO BE TAKEN FOR PREPARING LEGAL DOCUMENTS
(For guidance to Tenderer):

1. Non-Judicial stamp paper

- (i) Should have been purchased in the name of the Company/firm/executants
- (ii) Should be purchased from the Place/State where the document is being executed.
- (iii) Values of the non judicial stamp paper (NJSP) should be as mentioned in Tender conditions, where value of NJSP is not mentioned in the tender conditions, value of NJSP should as per the law of the state in which the document is being executed.
- (iv) Date of purchase of Non-Judicial stamp paper should be prior from the date of execution of document.

2. Signature on the document

- (i) The document should be signed on each page and also at the appropriate place meant for signature of executants/deponent.
- (ii) Signatory/executants should ensure that on the date of signing the document he/she has valid authority/attorney in his/ her favour for signing.
- (iii) In affidavit declaration clause as well as verification clause both should be signed by deponent/ executants.
- (iv) Where the document requires witnessing, it should be duly signed by witnesses alongwith their names and addresses.
- (v) On Power of Attorney, signatures of the Attorney holder should also be got done and attested by executants.

3. Format of the document

- (i) Where the format has been prescribed by the RCIL, the document should be executed in that format.
- (ii) Date and place of execution should be mentioned on the document.

4. Notarization of document

- (i) The document should be duly attested (signed and stamped) by notary public on each page.
- (ii) The seal of the notary public should contain his name, area of practice and Registration number.
- (iii) Notarial stamps of appropriate value wherever required should be affixed on the document

RailTel Corporation of India Limited /NEW DELHI.**E-TENDER NOTICE****TENDER NO.: RCIL-SIG-.....****DATE:**

RailTel Corporation of India Ltd. (a Public Sector Enterprise under Ministry of Railway) invites open e-tender under Single packet system on the prescribed form for the following work:

1	Name of work	“Construction of Eight number Gate Goomty at Chinna (L-Xing 33) in VKA-CHN Section; Gurudaspur (L-Xing 53 & 54), Dhariwal (L-Xing 38) in DHW-SRM Section; Nurmahal (L-Xing 18), Bilga (L-Xing 11 & 12); Nakodar (L-Xing 36) in LNK -PHR Section”.
2	Approximate cost of the work	Rs. 26,40,648.80 /-
3	Earnest money	Rs. 53,000/-
4	Similar Nature of Work	Any Civil Engineering Work. Note 1- Tenderer may be required to submit the schedule of those works, Completion/Performance Certificates of which have been submitted by him/her in support of 30/40/60% (as the case may be) criterion of similar nature of work.
5	Completion period	06 (Six) months from the date of issue of Letter of Acceptance.
6	Validity of offer	60 days from the date of opening of tender.
7	Website where tender bid can be submitted	1. Bids are to be submitted online only. 2. Tenderer/s must register on Indian Railway E-Procurement System (IREPS) site i.e. www.ireps.gov.in for participating in e-tender system. Necessary changes, Corrigendum/Addendum if required, would be posted on this site as well as RCIL website only. 3. Bidders will be able to submit their original/revised bids up to closing date & time through IREPS portal only. 4. Manual bids/offers are not allowed against this tender. Any manual offer received shall be ignored.
8	Cost of the Tender Document	NIL

Critical Dates

Code	Activity	Date
D0	Date of availability of tender document on www.ireps.gov.in	16.08.23
D1=D0+07 days	Start of submission of offer on www.ireps.gov.in	22.08.23
D2=D0+21 days	End of availability of tender document at www.ireps.gov.in and opening of tender/offer	05.09.23

Reference time for all the above activities is 15:30 hours

NOTE: In case the intended date for opening of tenders is declared a holiday, the tenders will be opened on the next working day at the same time.

INSTRUCTION TO BIDDERS

1.0 Scope of Work: “Construction of Eight number Gate Goomty at Chinna (L-Xing 33) in VKA-CHN Section; Gurudaspur (L-Xing 53 & 54), Dhariwal (L-Xing 38) in DHW-SRM Section; Nurmahal (L-Xing 18), Bilga (L-Xing 11 & 12); Nakodar (L-Xing 36) in LNK -PHR Section”.

1.1 Definition of Similar Nature of Work:

Definition of Single similar work	
Any Civil Engineering Work	
Note 1:	Tenderer may be required to submit the schedule of those works, Completion/Performance Certificates of which have been submitted by him/her in support of 30/40/60% (as the case may be) criteria of similar nature of work.

1.2 Mandatory technical details to be attached along with the offer: (Not Applicable)

2.0 Submission of Tender Documents & Opening-

The tenders may be uploaded up to date D2 along with scanned copy of all the requisite document (as per Annexure 1& 2).

- Bids will be opened on Date D2 immediately after close of uploading of tenders.
- Tenderer may have to produce the original Documents at short notice whenever asked by RCIL at any stage of tender evaluation process or even after finalization of tender.
- In E-tender, all submissions of documents are to be uploaded on web-site. There may be last minute hic-cups and delay in uploading the Earnest Money and Documents etc. Tenderer's / Prospective bidders are advised to upload their offer well in time. RCIL will not be responsible for any delay/non submission of offer due to any reason whatsoever.

Note

- 1.0 Special attention is invited for the tenderers
- (a) Tender will be summarily rejected in case of non submission of Annexure - M, Q & S.
 - (b) In case of tender value more than Rs. 20 crore, tender will be summarily rejected in case of non submission of Annexure-H & N (bid capacity evaluation).

2.1 Instructions regarding GST

- (i) Works contracts shall be treated as supply of services as per schedule-IIGST Act.

- (ii) GST Act and Rules issued from time to time by the Government/ concerned authorities shall be applicable.
- (iii) The successful Contractor/ suppliers/ service providers/ parties immediately after the award of tender shall register their firms under GSTIN (GST Identification Number) and submit immediately after the award of contract, without which no payment shall be released to the Contractor. The Contractor shall be responsible for deposition of applicable GST to the concerned authority.

3.0 In case tender value upto Rs.10 crore (Single packet)

The tender uploaded by the tenderer(s) will consist of Single Packet/Files i.e. Packet-I/File-I having (a) Tender form (First sheet)(b) Special Tender Conditions and Instructions to tenderer/s (c) Special Conditions relating to site data and specifications (d) Schedule of Items, Rates, and Quantities. This Bid shall contain all the documents as listed Annexure-1 & Annexure-2 of Tender Notice.

**4.0 In case tender value more than Rs.10 crore (For Two Packet Tender)
(Not Applicable for this tender)**

5.0 “JVs shall be considered in accordance with approved tender conditions.”

NOTE:

1. The bidders who desires to participate against e-tenders, are advised to electronically register themselves on website www.ireps.gov.in for which they would require to obtain Class III digital certificate (if already not obtained) issued by CCA under IT Act-2000.
2. All other terms and conditions in respect of above tender are given in the tender document.
3. Only e-tenders will be accepted and tenders submitted in any other form will be summarily rejected.
4. After opening of the tender, any document pertaining to the constitution of Sole Proprietorship Firm / Partnership Firm / Registered Company/ Registered Trust / Registered Society / HUF etc. shall be neither asked nor considered, if submitted. Further, no suo moto cognizance of any document available in public domain (i.e., on internet etc.) or in Railway's record/of- fice files etc. will be taken for consideration of the tender, if no such mention is available in tender offer submitted.

Executive Director/RP
RailTel Corporation of India Limited,
Delhi

Annexure-1

Scanned copy Of the Documents to be uploaded along with offer

Sno	Subject/Context	Required Documents/Form	Action if required documents not submitted along with the tender
1	Cost of Tender Document (in terms of Clause 2.1.2 (a) of tender document)	NIL (In case of e-tender mode)	Summarily Rejected (In case of tender other than e-tender mode)
2	Earnest Money Deposit (in terms of Clause 3.0 of tender document)	ONLINE MODE (no documentary proof required)	Summarily Rejected
3	Constitution of Firm documents (as required in terms of Clause 2.4 of the tender document)		As per Clause 2.4.1.1 of Special Tender conditions and instruction to the tenderer,
A	In case of Sole Proprietorship Concern	Undertaking as per Annexure O-1) Undertaking may be given. If not given As per para 14(iii) of GCC- 2022, If it is NOT mentioned in the submitted tender that tender is being submitted on behalf of a Sole Proprietorship firm/Partnership firm/Joint Venture/Registered Company etc., then the tender shall be treated as having been submitted by the individual who has signed the tender.	After opening of the tender, any document pertaining to the constitution of Sole Proprietorship Firm / Partnership Firm / Registered Company/ Registered Trust / Registered Society / HUF etc. shall be neither asked nor considered, if submitted. Further, no suo moto cognizance of any document available in public domain (i.e., on internet etc.) or in RCIL record/office files etc. or in RCIL/Railway will be taken for consideration of the tender, if no such mention is available in tender offer submitted.
B	In case of a "Partnership Firm/Concern"	(i) Notary certified copy of the Partnership Deed. (ii) Document(s) in support of Registration of firm with Registrar of firms which includes Certificate of registration and register of firm (Form No. may vary from State to State) (as applicable) etc. issued by Registrar of firms. (iii) Notarised / Registered Power of Attorney in favour of the individual signing the tender document authorized by all the partners to act on behalf of the firm and create liability against the Firm. (Standard Performa as per Annexure O-2 is enclosed for guidance)	

		<p>(iv) An undertaking by all partners of the partnership firm that they are not blacklisted or debarred by RCIL/Railway or any other Ministry / Department of the Govt. of India from participation in tenders / contracts as on the date of opening of bids, either in their individual capacity or in any firm in which they were / are partners. Concealment / wrong information in regard to above shall make the contract liable for determination under Clause 62 of the General Conditions of Contract.</p> <p>Note: Authorisation given in POA only will be considered irrespective of any authorization that may have given in Partnership Deed. In case of non-submission of POA or invalid POA, offer is liable to be rejected.</p>	<p>Note: If all the requisite documents pertaining to the constitution of the firm/sole proprietorship/partnership firm/company/Society/LLP/HUFetc., as specified in clause 2.4.1 above, are not submitted, offer will be considered as incomplete and shall be summarily rejected.</p>
C	In case of a “JV Firm” (Not Applicable for this tender)	<p>(i) A copy of Memorandum of Understanding (MoU) duly executed by the JV members on a stamp paper, shall be submitted by the JV alongwith the tender. The complete details of the members of the JV, their share and responsibility in the JV etc. particularly with reference to financial, technical and other obligations shall be furnished in the MoU.</p> <p>(ii) Power of Attorney/authorization duly Notarised by all JV constituents, in favour of the individual under whose digital signature key the tender document shall be uploaded on behalf of JV for signing the tender document on behalf of the JV (Standard Performa as per Annexure O-3)</p>	
(c) (i)	In case one or more of the members of the JV Firm is/are Partnership Firm(s), following documents shall be submitted:	<p>(i) Notary copy of the Partnership Deed. Document(s) in support of registration of firm with registrar/Sub-Registrar of firms viz. Certificate of registration and register of firm (Form No. may vary from State to State) etc. issued by registrar of firms.</p> <p>(ii) A copy of consent of all the partners or individual authorized by partnership firm, to enter into the Joint Venture Agreement on a stamp paper (Standard Performa as per Annexure O-4)</p> <p>(iii) A copy of Power of Attorney (duly notarized/registered) in favour of the individual to sign the MOU/JV Agreement on behalf of the partnership firm and create liability against the firm. (Standard Performa as per Annexure O-5)</p> <p>Note: Authorisation given in POA only will be considered irrespective of any authorization that may have given in Partnership Deed. In case of non-submission of POA or invalid POA, offer is liable to be rejected.</p>	

(c) (ii)	In case one or more of the members of the JV Firm is/are Proprietary Firm or HUF, following documents shall be submitted:	(i) A copy of notarized affidavit on Stamp Paper declaring that he who is signing the affidavit on behalf of HUF is in the position of 'Karta' of Hindu Undivided (HUF) and he has the authority, power and consent given by other members to act on behalf of HUF. (Standard Affidavit as per Annexure O-6) Performa as per Annexure O-6)	
C(iii)	In case one or more members of JV is/are Limited Companies, the following documents shall be submitted:	(i) A copy of resolutions of the Directors of the Company, permitting the company to enter into a JV agreement, (Standard Performa as per Annexure O-7) Copy of Memorandum and Articles of Association of the Company Copy of certificate of incorporation (iv) A copy of Authorization/copy of Power of Attorney issued by the Company (backed by the resolution of Board of Directors) in favour of the individual to sign the tender, sign MOU/JV Agreement on behalf of the company and create liability against the company (Standard Performa as per Annexure O-8)	
C(iv)	In case one or more members of JV is/are LLP firm, the following documents shall be submitted/uploaded	(a) A notarised copy of certificate of incorporation and LLP agreement. (b) A notarised copy of resolution of the partners of LLP, permitting the LLP to enter into a JV agreement, authorising one of the partners of LLP to sign JV MOU/agreement and such other documents required to be signed on behalf of the LLP and to create liability against the LLP and/or to do any other act on behalf of LLP (Standard proforma as per Annexure O-13) A copy of authorisation/copy of power of attorney issued by the LLP (backed by resolution of partners) in favour of individual to sign the tender, sign MOU/JV agreement on behalf of the LLP and create liability against the LLP (Standard proforma as per Annexure O-14)	
<p>Note:- All the Members of JV shall certify that they are not blacklisted or debarred by RCIL/Railways or any other Ministry / Department of the Govt. of India from participation in tenders/contract on the date of opening of bids either in their individual capacity or as a member of the JV in which they were/are members.</p>			
(D)	In case of a "Company"	(i) Copies of the AOA / MOA (Article of Association/ Memorandum of Association) of the Company (ii) A copy of certificate of incorporation. (iii) A copy of Authorization/Power of Attorney issued by the Company (backed by the resolution of Board of Directors) in favour of the individual to sign the tender on behalf of the company and create liability against the company (Standard Performa as per Annexure O-9, 10).	

		(iv) An Undertaking that the company is not black listed or debarred by RCIL/Railways or any other Ministry/Department of Govt. of India from participation in tender on the date of opening of bids, either in individual capacity or as a member of the partnership firm or JV in which the company was/is a partner/member. Concealment/wrong information in regard to above shall make the contract liable for determination under clause 62 of the General Conditions of contract.	
I	In case of a Registered Society & Registered Trust	(i) copy of the certificate of registration; (ii) copy of Deed of formation; and (iii) Notorized copy of Power of Attorney in favour of the individual to sign the tender documents and create liability against the Society/Trust	
F	In case of LLP	A copy of LLP Agreement, A copy of Certificate of Incorporation; and A copy of Power of Attorney/Authorization issued by the LLP in favour of the individual to sign the tender on behalf of the LLP and create liability against the LLP (Standard proforma as per Annexure O-11 & O-12). (iv) An Undertaking that the LLP is not black listed or debarred by RCIL/ Railways or any other Ministry/Department of Govt. of India from participation in tender on the date of opening of bids, either in individual capacity or as a member of JV in which the LLP was/is a member. Concealment/wrong information in regard to above shall make the contract liable for determination under clause 62 of the General Conditions of contract.	
G	In case of HUF	(i) A copy of notarized affidavit on Stamp Paper declaring that he who is submitting the tender on behalf of HUF is in the position of 'Karta' of Hindu Undivided (HUF) and he has the authority, power and consent given by other members to act on behalf of HUF. (Standard proforma as per Annexure O-15). (ii) An undertaking that the HUF is not blacklisted or debarred by RCIL/Railways or any other Ministry / Department of Govt. of India from participation in tender on the date of opening of bids, either in individual capacity or as a member of the partnership firm or JV in which HUF was / is a partner/member. Concealment / wrong information in regard to above shall make the contract liable for determination under Clause 62 of the General Conditions of Contract.	

Annexure-2

Scanned copy of Document required to be uploaded along with the offer

S No.	Detail of documents	Summarily/Liable to be rejected
1.	Technical Eligibility Criteria:- Completion/Performance Certificate in support of 30%/40%/60% similar nature of work as per clause 2.3.2.A(v) of tender document.	Liable to be Rejected <u>Note</u> <i>As per Note(i) of para 7 of Check List and in para 1 of Covering note</i>
2.	Financial Eligibility Criteria:- Contractual payment received as per Annexure- I and as per clause 2.3.2 (A) (vi) of Tender Document.	<i>“After opening of the tender, any document/credential pertaining to the technical & financial eligibility and available bid capacity, constitution of firm etc. shall neither be asked nor be entertained/considered under any circumstances and no claim or representation whatsoever from the tenderer in this regard shall be entertained”</i>
3.	Annexure-C (Declaration form regarding site etc.)	Liable to be rejected
4.	Annexure-D (Declaration regarding constitution of firm)	Liable to be rejected
5.	Annexure-E (Plant and Machinery)	Liable to be rejected
6.	Annexure-F (Engineers/Personnel)	Liable to be rejected
7.	Annexure-G (Work executed in last sevenyears)	Liable to be rejected
8.	Annexure-H (Work in Hand) in support of Bid Capacity) (Applicable for tender value more than Rs. 20 crore)	In terms of Clause 2.3.2 (A) (XIV) of tender document Summarily Rejected
9.	Annexure-I (Contractual Payment received) :	Liable to be rejected
10.	Annexure-J (Bank Detail/RTGS)	Liable to be rejected
11.	Annexure-L (Performa of Completion Certificate)	Liable to be rejected
12.	Annexure-M certificateto be submitted by tenderer alongwith the tender documents	Summarily Rejected
13.	Annexure-N (Contractual payment received in last three years) in support of Bid Capacity (Applicable for tender value more than Rs. 20 crore)	In terms of Clause 2.3.2 (A) (XIV) of tender document Summarily Rejected
14.	Annexure-Q –Mandatory undertaking/Certificate Regarding Employment/ Partnership of Retired RCIL/ Railway Employees.	Summarily Rejected
15.	Attested copy of Ballast Test Report, to be submitted, (Only for pure ballast supply tenders). As per Railway Board letter No. 2007/CE-II/MB/I dated 30.12.2019.	Not applicable for this tender.

16.	Annexure – S (Instructions for bidders from a country which shares a land border with India) – As per Railway Board letter No. 2020/CE-I/CT/2/GCC/Correspondence, dated 11.08.2020	Summarily Rejected
17	Annexure – T1 Bid Security Declaration in lieu of EMD (Mandatory certificate to be submitted).	Not applicable: Deleted
18	Annexure – K-3 & K-4	If tender submitted on behalf of Partnership Firm, relevant Annexures K-3 and K-4 as Declaration to be submitted by the tenderer alongwith tender document.
21	Annexure-U (Integrity Pact) Mandatory	Not applicable for this tender.



COVERING NOTE

FOR THE SPECIAL ATTENTION OF THE TENDERERS

1. The tenderers are requested to carefully peruse the Tender Documents, and upload all requisite documents/ credentials along with the offer. Scanned copy of the documents, uploaded by the tenderer shall be clear & readable. Documents submitted/ uploaded previously or along with another tender currently under consideration SHALL NOT be considered while evaluating the present tender.
2. The tenderer(s) shall visit the site of work and acquaint himself/themselves with the conditions of work viz. approach roads and accessibility, nature of soil/rock, availability of materials, electric power, water for work and drinking purposes, site for labour camps, stores, godowns, extent of lead/lift in work, availability of skilled and unskilled labour etc. that may be encountered in the course of execution of work. In short, he/they should familiarize himself/themselves fully with the conditions of the site and FURNISH A CERTIFICATE TO THIS EFFECT, in the Proforma appended as **Annexure-C**.
3. FURTHER, OFFERED RATES SHOULD BE FILLED UP IN THE TENDER SCHEDULE at specified space. RATES OFFERED IN ANY OTHER PROFORMA/FORM WILL BE SUMMARILY REJECTED.
4. **In case tender value upto Rs. 10 crore (Single packet)**
 - 4.1 The tender uploaded by the tenderer(s) will consist of Single Packets/ Files i.e. Packet-I/File-I having (a) Tender form (First sheet) (b) Special Tender Conditions and Instructions to tenderer/s (c) Special Conditions relating to site data and specifications (d) Schedule of Items, Rates, and Quantities. This Bid shall contain all the documents as listed Annexure-1 & Annexure-2 of Tender Notice. Tenderers are requested to ensure that all such documents and Annexures duly filled in are uploaded, complete in all respects with their Packet-I/File-I failing which his/their offer is likely to be rejected/summarily rejected, as applicable. Tender will be opened on Date D2, i.e. immediately after close of uploading of tenders
- 5.0 **In case tender value more than Rs.10 crore (Two packet system), (Not Applicable)**
- 6.0 To be opened on scheduled date and time and shall be uploaded along with the following documents:
 - (i) Earnest Money **ON LINE MODE (Refer clause 3.0)**
 - (ii) All other mandatory documents as listed in the document
- 7.0 Note:- Tenderer(s) to please note that after opening of tender, any document/credential pertaining to technical & financial eligibility, constitution of firm etc. shall neither be asked nor be entertained/ considered under any circumstances and no claim or representation whatsoever from the tenderer in this regard shall be entertained. Scanned copy of the documents, uploaded

by the tenderer shall be clear & readable. However, RCIL reserves the right to seek any clarification on the documents/credentials already submitted by the tenderer along with the offer.

- 7.1 Tenderer should keep the validity of their offer for 60 days. Any deviation from this will not be accepted under any circumstances.
- 8.0 Tenderer may have to produce the original Documents in physical form at short notice whenever asked by RCIL at any stage of tender evaluation process or even after finalization of tender.
- 9.0 In E-tender, all submissions of documents are to be uploaded on web-site. There may be last minute hic-cups and delay in uploading the Documents and payment of Earnest Money etc. Tenderer's/Prospective bidders are advised to upload their offer well in time. RCIL will not be responsible for any delay/non submission of offer due to any reason whatsoever.
- 10.0 Each page of the tender papers will be treated as signed/ accepted by the tenderer(s) or such person(s) on his/their behalf who is/are legally authorized to sign for him/them.
- 11.0 The tenderer(s) may note that the RCIL reserves its right to either accept or reject any Bid/s without assigning any reasons whatsoever and tenderer(s) shall have no claim(s) on this account.
- 12.0 Public Procurement (Preference to Make in India):- The tenderer shall comply with Public Procurement Policy order 2017 – Details of which is elaborated in Clause No. 2.3.4 of "*Special Tender Conditions and Instruction to tenderer(s)*"
- 13.0 Prospective tenderer(s) may contact RailTel Corporation of India Limited, 6th Floor, 3rd block, Delhi Technology Park, Shastri Park, Delhi-110053 for obtaining further clarifications, if required during working hours.

रेलटेल
RAILTEL

Integrity Pact Program (Applicable for more than 15 Crores)

Bringing the practices in RailTel Corporation of India Limited up to the internationally acclaimed best practices for raising integrity levels in procurement of works and services, RailTel is implementing the Integrity Pact Program in line with the recommendation of Central Vigilance Commission (CVC).

The Integrity Pact Program envisages an 'Integrity Pact', an agreement between the prospective Bidders & Contractors and RailTel, committing the persons/ officials of both parties, not to exercise any influence on any aspect of the contract.

Coverage:

The Integrity Pact Program will cover the following tenders/procurements:

All tenders relating to procurement of OFC, quad cable, pre-fab shelters, electronic equipments and its installations and/or commissioning etc and other item(s) or activity/activities proposed to be carried out or required by the Company for the value exceeding **Rs.15 crores** at a time including for repair and maintenance of cable /network and any other items required for special works assigned to RailTel

Implementation:

The accompanying 'Integrity Pact' will be issued along with the bidding documents and will also be uploaded on the website.

Bidder of Indian origin shall submit the Integrity Pact (in 2 copies) on a non judicial stamp paper of Rs. 100/- duly signed by the person signing the bid. Bidder of foreign origin may submit the Integrity Pact on its company's letter head, duly signed by the person signing the bid.

If the bidder is a partnership or a consortium, the Integrity Pact shall be signed by all the partners or consortium members.

The 'Integrity Pact' shall be returned by the Bidder duly signed along with the Bid in a separate envelope, duly super scripted with 'Integrity Pact'.

On behalf of RailTel, the Integrity pact will be signed by the concerned representative of the Projects department in the Bid Opening Committee immediately on receipt of Integrity Pact signed by the Bidder at the time of Bid opening. One copy of the Integrity Pact shall be retained by RailTel and the 2nd copy will be issued to the representative of the bidders during bid opening. If the Bidders representative is not present during the Bid opening, the 2nd copy shall be sent to the bidder by post/courier.

Bidder's failure to submit the Integrity Pact duly signed along with the Bid shall lead to outright rejection of the Bid.

The bidder shall not change the contents of the Integrity pact.

All the pages of the Integrity Pact are to be signed by both RailTel and the Bidder.

Independent External Monitors (IEMs):

1. CMD of RailTel is the authority to appoint Independent External Monitor(s) to oversee Integrity Pact Program's implementation and effectiveness with respect to the tenders/procurements to which Integrity Pact Program applies. For this purpose, CVC would nominate IEMs for RailTel from the panel of IEMs maintained by it. The Terms and Conditions of their appointment would be decided by CMD, RailTel in line with CVC guidelines in the matter.
2. In all tenders covered under the Integrity Pact, particulars of all IEMs, including their email IDs should be mentioned.
3. A copy of such Tender Document shall be forwarded to both IEM's promptly after publishing of the same, Information regarding the contracts awarded against the said Tender shall be provided to the concerned IEM at regular intervals as decided in consultation with CVO. Additional details/documents, if any, shall be furnished to the concerned IEM/IEMs, as and when sought by them.
4. IEM/IEMs shall provide their opinion on the complaints received by them to CMD, RailTel at the earliest. They may however send their report directly to the CVO in case of suspicion of serious irregularities requiring legal/administrative action.



OFFER LETTER

Tender No. TENDER NO. RCIL-SIG-GOOMTY_23-24-15, Dt. 16.08.2023

Name of Work "Construction of Eight number Gate Goomty at Chinna (L-Xing 33) in VKA-CHN Section; Gurudaspur (L-Xing 53 & 54), Dhariwal (L-Xing 38) in DHW-SRM Section; Nurmahal (L-Xing 18), Bilga (L-Xing 11 & 12); Nakodar (L-Xing 36) in LNK -PHR Section".

To,
Executive Director/Railway Project,
Shastri Park/Delhi

1. I/We-----
-----have read all the conditions of the tender attached here with and agree to abide by the said conditions. I/We also agree to keep this tender open for acceptance for a period of 60 days for the tender value more than Rs.10 cr tender value from the date fixed for opening the same and in default thereof, I/We will be liable for forfeiture of my/our "Earnest Money". I/We offer to do this work "Construction of Eight numbers Gate Goomty at Chinna (L Xing 33) in VKA-CHN section; Gurudaspur (L Xing 53 & 54), Dhariwal (L Xing 38), Jhakolari (L Xing 69) in DHW-SRM Section; Nurmahal (L Xing 18), Bilga (L Xing 11 & 12), Nakodar (L Xing 36) in LNK-PHR Section".for Northern Railway at the rates quoted in the attached schedule (Financial Bid) and hereby bind myself/ourselves to complete the work in all respects within 06 (Six) months from the date of issue of letter of acceptance of the tender.
2. I/We also hereby agree to abide by the General Conditions of Contract April, 2022 corrected up to printed/ advance correction slip and to carry out the work according to the Special Tender Conditions of Contract and **Indian Railway Unified Standard Specifications (Works & Materials), Engineering Department, 2010, Volume I & II, and Unified Standard Schedule of Rates (Works and Materials), 2010, corrected up to printed/advance correction slip(s) and Special Conditions relating to Site Data and Specifications.**
3. **Earnest Money Deposit (EMD):**
 - 3.1 Bid security declaration: Deleted.
 - 3.2 I/We shall be banned from submission of bids in any Works/Service Tender issued by Indian Railway/RCIL for a period of 12 months from the date of such banning done on e-platform IREPS, OR the full value of the Earnest Money

Deposit (EMD) and other dues shall stand forfeited whichever applicable, without prejudice to any other rights or remedies in case my/ our Tender is accepted and if: -

- (a) I/We do not submit the Performance Guarantee within the time specified in the Tender document;

- (b) I/We do not execute the contract documents within **Seven days** after receipt of the notice issued by RCIL that such documents are ready; and
- (c) I/We do not commence the work within **fifteen days** after receipt of orders to that effect;
- (d) I/We do not submit a Performance Guarantee in any of the forms as prescribed in clause 5.2 of "SPECIAL TENDER CONDITIONS AND INSTRUCTIONS TO TENDERERS" amounting to 10% of the contract value as per the Performa as prescribed by the , RCIL within 21(twenty one) days from the date of issue of letter of acceptance (LOA) or 60 (sixty) days, if the extension of time for submission of PG beyond 21 days and upto 60 days is given by the competent authority along with interest @ 15%per annum for the delay beyond 21days and upto 60 days from the date of issue of LOA. Further, if the 60th day happens to be a declared holiday in the concerned office of the RCIL, submission of PG can be accepted on the next working day. I/We shall also be debarred from participating in re-tender of the above work, in case I/we fail to submit the PG as stipulated above.

The Performance Guarantee shall be initially valid upto the stipulated date of completion plus 60 days beyond that. In case, the time for completion of work gets extended, the contractor shall get validity of Performance Guarantee extended to cover such extended time for completion of work plus 60 days. The value of PG to be submitted by the contractor will not change for variation upto 25% (either increase or decrease).

In case during the course of execution, value of the contract increases by more than 25% of the original contract value, an additional Performance Guarantee amounting to 10% (Ten percent) for the excess value over the original contract value shall be deposited by the contractor.

On the other hand, if the value of Contract decreases by more than 25% of the original contract value, Performance Guarantee amounting to 3% (Three percent) of the decrease in the contract value shall be returned to the contractor. The PG amount in excess of required PG for decrease contract value, available with, RCIL shall be returned to contractor as per their request duly safeguarding the interest of RCIL.

- 4 (a) I/We am/are a Startup firm registered by Department of Industrial Policy and Promotion (DIPP) and my registration number is valid upto (Copy enclosed) and hence exempted from submission of Earnest Money
- 5. We are a 100% Govt. owned PSUs and hence exempted from payment of Earnest Money.
- 6. We are a Labour Cooperative Society and our Registration No. is withand hence required to submit Bid Security Declaration on IREPS (Refer detailed instructions at Annexure-T) OR deposit only 50% of Earnest Money, whichever applicable. (Para 3.1 A & B)
- 7. Until a formal agreement is prepared and executed, acceptance of the tender shall constitute a binding contract between us subject to modifications, as may

be mutually agreed to between us and indicated in the letter of acceptance of my/our offer for this work.

Signature of the Tenderer(s)

Signature of Witnesses:-

Date:

1. _____
2. _____

Address of the Tenderer(s)

(Complete postal address)



रेलटेल
RAILTEL

VOLUME – I
SPECIAL TENDER CONDITIONS
AND INSTRUCTION TO TENDERERS

रेलटेल
RAILTEL

SPECIAL TENDER CONDITIONS AND INSTRUCTION TO TENDERER(S)

1.0	<p>DETAILS OF WORKS: “Construction of Eight number Gate Goomty at Chinna (L-Xing 33) in VKA-CHN Section; Gurudaspur (L-Xing 53 & 54), Dhariwal (L-Xing 38) in DHW-SRM Section; Nurmahal (L-Xing 18), Bilga (L-Xing 11 & 12); Nakodar (L-Xing 36) in LNK -PHR Section”.</p>
	Tenders are invited for the work “ AS ON TOP SHEET ”
2.0	<p><u>TENDER DOCUMENTS:</u></p> <p>A <u>In case of tender value upto Rs. 10 Crore (Single Packet)</u></p> <p>The following document will form parts of tender /document having</p> <ul style="list-style-type: none"> • Top sheet, • Tender Notice, • Addendum/Corrigendum, if any, • Covering Note • Tender form (First sheet) • Special Tender Conditions and Instructions to tenderer/s along with related Annexures, • Special Conditions relating to site data and specifications along with related Annexures, • Schedule of Items, Rates, and Quantities. • This Bid shall contain all the documents as listed Annexure-1 & Annexure-2 of Tender Notice. • Tenderers are requested to ensure that all such documents and Annexures duly filled in are uploaded, complete in all respects failing which his/their offer is likely to be rejected/summarily rejected, as applicable. <p>NOTE</p> <ul style="list-style-type: none"> • Standard General Conditions of Contract and Standard Specifications (Works and Materials) of Indian Railway as amended/corrected upto latest correction slips. • All general and detailed drawings pertaining to this work which will be issued by the Engineer or his representatives (from time to time) with all changes and modifications
2.1	<u>SUBMISSION OF TENDERS:</u>
2.1.1 (a)	<p>The offer is to be uploaded online upto 05.09.2023 by 1500 hrs (D2) along with scanned copy of all the requisite document (as per Annexure 1 & 2 of tender notice).</p> <ul style="list-style-type: none"> • Tenderer may have to submit the original Documents in physical form at short notice whenever asked by RCIL at any stage of tender evaluation process or even after finalization of tender. • In E-tender, all submissions of documents are to be uploaded on web-site. There may be last minute hic-cups and delay in uploading the Documents and payment of Earnest Money, as applicable etc. Tenderer’s/Prospective bidders are advised to upload their offer well in time. RCIL will not be responsible for any delay/non submission of offer due to any reason whatsoever.
2.1.1 (b)	Care in submission of tender
(i)	<p>Before submitting a tender, the tenderer will be deemed to have satisfied himself by actual inspection of the site and locality of the works, that all conditions liable to be encountered during the execution of the works are taken into account and that the rates he enters in the tender forms are adequate and all inclusive to accord with the provisions in Clause-37 of the Standard General Conditions of Contract for the completion of works to the entire satisfaction of the Engineer.</p>

(ii)	Tenderers will examine the various provisions of The Central Goods and Services Tax Act, 2017(CGST)/Integrated Goods and Services Tax Act, 2017(IGST)/Union Territory Goods and Services Tax Act, 2017(UTGST)/ respective state's State Goods and Services Tax Act (SGST) also, as notified by Central/State Govt & as amended from time to time and applicable taxes before bidding. Tenderer's will ensure that full benefit of Input Tax Credit (ITC) likely to be availed by them is duly considered while quoting rates.
(iii)	The successful tenderer who is liable to be registered under CGST/IGST/UTGST/SGST Act shall submit GSTIN along with other details required under CGST/IGST/UTGST/SGST Act to RCIL immediately after the award of contract, without which no payment shall be released to the contractor. The contractor shall be responsible for deposition of applicable GST to the concerned authority.
(iv)	In case the successful tenderer is not liable to be registered under CGST/IGST/UTGST/SGST Act, the RCIL shall deduct the applicable GST from his/their bills under reverse charge mechanism (RCM) and deposit the same to the concerned authority.
2.1.2	<p>Cost of Tender Documents</p> <p>(a) The cost of tender document is Nil. This will be applicable for tenders other than e-tender mode. This should be paid separately and not included in the Earnest Money of tender.</p> <p>(b) However, For service contracts, MSMEs registered with District Industries Centres, Khadi and Village Industries Commission, Khadi and Village Industries Board, Coir Board, National Small Industries Corporation, Directorate of Handicraft and Handloom, Any other body specified by Ministry of MSME, shall be supplied such tender document free of cost on confirmation of their evidence to this effect.</p>
2.1.3	In case the intended date for opening of tenders is declared a holiday, the tenders will be opened on the next working day at the same time
2.2	<u>COMPLETION OF TENDER DOCUMENTS:</u>
2.2.1	The tenderers shall quote the Single Rate for Each Schedule % age "Above/Below/At par"- Every possible fluctuation, in the rate of labour, material and general commodities, and other possibilities of each and every kind which may affect the rates, should be considered and kept in view before quoting the rates and no claim on this account shall be entertained by RCIL under any circumstances except the price escalation payable as per price variation clause, if any, provided separately in the tender documents."
2.2.2	The quantities shown in the attached Schedule are given as a guide and are approximate only and are subject to variation according to the needs of the RCIL. The RCIL does not guarantee work under each item of the Schedule. The tenderer(s) shall quote rates / rebates only at specified place in Tender Form supplied by RCIL. Any revision of rates / rebates submitted (quoted) through a separate letter whether enclosed with the bid (Tender Form) or submitted separately or mentioned elsewhere in the document other than specified place shall be summarily ignored and will not be considered. In case of tender other than e-tender mode, Multiple Rates- in case tenderer/s quote selective rebate on any individual item(s) of a USSOR Chapter of Schedule-A/Individual NS item of Schedule-B, the same will be treated as multiple rate and their offer will be summarily rejected.
2.2.3	Each page of the tender papers will be treated as signed/ accepted by the tenderer(s) or such person(s) on his/their behalf who is/are legally authorized to sign for him/them and to enter into commitments on their behalf.

2.2.4	The rates, rebates and/or other financial terms, if any, quoted by tenderer in the relevant fields of the Financial Bid page will only be the ruling terms for deciding the inter-se ranking, and any such condition having financial repercussions, if quoted by them anywhere else including attached documents shall not be considered for deciding inter-se ranking
2.2.5	Additional conditions or stipulations, if any, must be made by the tenderer/s in a covering letter with the tender. The RCIL reserves the right not to consider conditional tenders and reject the same without assigning any reason. Only those additional conditions which are explicitly accepted by the RCIL shall form part of the contract.
2.2.6.	<p>The tenderers shall upload a certificate stating that they are not liable to be disqualified and all their statements/documents submitted alongwith bid are true and factual. Standard format of the certificate to be submitted by the bidder is enclosed as Annexure-M. Non submission of a certificate by the bidder shall result in summarily rejection of his/their bid and it shall be mandatorily incumbent upon the tenderer to identify, state and submit the supporting documents duly self attested by which they/he is qualifying the Qualifying Criteria mentioned in the Tender Document. It will not be obligatory on the part of Tender Committee to scrutinize beyond the submitted document of tenderer as far as his qualification for the tender is concerned.</p> <p>If contents in documents uploaded/submitted by tenderers are found to be incorrect/false, action will be taken against such tenderers as per provisions contained in certificate submitted by them as annexure M. In such eventuality, next lowest eligible tenderer/offer will be considered.</p> <p>(Ref: RB letter No. 2022/CE-I/CT/GCC-2022/Policy dated 27-04-2022)</p>
2.2.7	<p>(a) The RCIL reserves the right to verify all statements, information and documents submitted by the bidder in his tender offer, and the bidder shall, when so required by the RCIL, make available all such information, evidence and documents as may be necessary for such verification. Any such verification or lack of such verification by the RCIL shall not relieve the bidder of its obligations or liabilities hereunder nor will it affect any rights of RCIL there under.</p> <p>b) In case of any information submitted by tenderer is found to be false forged or incorrect at any time during process for evaluation of tenders, it shall lead to forfeiture of the tender Earnest Money Deposit besides banning of business for a period of upto five years.</p> <p>(c) In case of any information submitted by tenderer is found to be false forged or incorrect after the award of contract, the contract shall be terminated. Earnest Money Deposit (EMD), Performance Guarantee and Security Deposit available with the RCIL shall be forfeited. In addition, other dues of the contractor, if any, under this contract shall be forfeited and agency shall be banned for doing business for a period of upto five years.</p>
2.2.8	Tenderer may have to submit the original Documents in physical form at short notice whenever asked by RCIL at any stage of tender evaluation process or even after finalization of tender.
2.2.9	In E-tender, all submissions of documents are to be uploaded on web-site. There may be last minute hic-cups and delay in uploading the Documents and submission of Bid Security Declaration <u>OR</u> payment of Earnest Money, as applicable etc. Tenderer's/Prospective bidders are advised to upload their offer well in time. RCIL will not be responsible for any delay/non submission of offer due to any reason whatsoever
2.2.10	Tenders containing erasures and / or alterations of tender documents are liable to be rejected. Any correction made by tender(s) in his/their entries must be attested by him/ them.
2.2.11	The works are required to be completed within a period of 06 (Six) months from the date of issue of acceptance letter.

2.2.12

Employment/Partnership etc. of Retired RCIL/Railway Employees:

- a) Should a tenderer
- i) be a retired Engineer of the gazetted rank or any other gazetted officer working before his retirement, whether in the executive or administrative capacity or whether holding a pensionable post or not, in the Engineering or any other department of any of the RCIL/Railways owned and administered by the President of India for the time being, OR
 - ii) being partnership firm / joint venture (JV) / registered society / registered trust etc have as one of its partners a retired Engineer of the gazetted rank or any other gazetted officer working before his retirement, OR
 - iii) being an incorporated company have any such retired Engineer of the gazetted rank or any other gazetted officer working before his retirement as one of its directors.

AND

in case where such Engineer or officer had not retired from government service at least 1 year prior to the date of submission of the tender

THEN

the tenderer will give full information as to the date of retirement of such Engineer or gazetted officer from the said service and as to whether permission for taking such contract, or if the Contractor be a partnership firm or an incorporated company, to become a partner or director as the case may be, has been obtained by the tenderer or the Engineer or officer, as the case may be from the President of India or any officer, duly authorized by him in this behalf, shall be clearly stated in writing at the time of submitting the tender.

- b) In case, upon successful award of contract, should a tenderer depute for execution of the works under or to deal matters related with this contract, any retired Engineer of gazette rank or retired gazetted officer working before his retirement in the Engineering or any other department of any of the RCIL/Railway owned and administered by the President of India for the time being, and now in his employment, then the tenderer will ensure that retired Engineer or retired gazetted officer had retired from government service at least 1 year prior to the date of his employment with tenderer and in case he had retired from service within a year then he possesses the requisite permission from the President of India or any officer, duly authorized by him in this behalf, to get associated with the tenderer.
- c) Should a tenderer or Contractor being an individual, have member(s) of his or in the case of partnership firm/ company / joint venture (JV) / registered society / registered trust etc. one or more of his partner(s)/shareholder(s) or member(s) of the partner(s)/shareholder(s) having share of more than 1% in the tendering entity employed in gazetted capacity in the Engineering or any other department of the RCIL/Railways, then the tenderer at the time of submission of tender, will inform the authority inviting tenders the details of such persons.

Note:- If information as required as per 2.2.12 a), b), c) above has not been furnished, contract is liable to be dealt in accordance with provision of clause 62 of Standard General Condition of contract .The undertaking shall be submitted as per Annexure-Q .

2.2.13	Any bidder from a country which shares a land border with India will be eligible to bid in this tender only if the bidder is registered with the Competent Authority. Detailed instructions in this regard are available at clause No. 2.4.3. Standard format of the certificate to be submitted by the bidder is enclosed as Annexure-S. In case of non-submission of above certificate, tender shall be summarily rejected. Evidence of valid registration by Competent Authority shall also be attached, wherever applicable.
2.3	<u>CREDENTIALS TO BE UPLOADED/SUBMITTED ALONGWITH TENDER DOCUMENTS: (ELIGIBILITY CRITERIA)</u>
2.3.1	Tenderer(s) should upload documents and certificates to show that he/they has/have satisfactorily carried out works of the type involved in the construction of the work being tendered for. He/they should also produce proof of the satisfaction of the RCIL of his/their technical ability and financial stability to undertake the work of the magnitude tendered for.
2.3.2	The tenderer(s) shall upload with his/their tender a list of serviceable machinery, tools and plants, equipment's and vehicles he/they has/have in hand for executing the work & those, he/they intends/intend to purchase.
2.3.2 (A)	The tenderer(s) must upload along with his/their tenders:-
(i)	Statement showing similar works executed by him/them
(ii)	Certificates of successful completion of his/their work
(iii)	<p>A statement of all payments received against all successfully completed work/ works in progress of all types (not necessarily similar in type to work in this tender)for three preceding financial years and the current financial year upto the date of inviting of the tender should be uploaded, as per Annexure- I, duly certified by Chartered Accountant. Contractual payment received should be based on Audited Balance Sheets or Form 16A /26AS generated through TRACES of IT or certificate from concerned Department / Client.</p> <p>Note: (i) Client certificate from other than Govt. Organisation should be duly supported by Form 16A/26AS generated through TRACES of IT Department. (ii) The Audited Balance Sheet or Form 16A /26AS from IT TRACES or Certificates from concerned Department / Client as referred for contractual payments received should be submitted alongwith the tender failing which payment received shall not be considered.</p> <p>(iii) In case the figure of contractual payment is not directly available in Audited Balance Sheet, the CA should obtain this figure from the Audited Account based on which the Balance Sheet has been prepared</p>
(iv)	A list of their Engineering Organization and equipments, construction Tools and Plants available with them.
(v)	Technical Eligibility Criteria (as per GCC-2022):
	<p>(a) The tenderer must have successfully completed any of the following (by any Government organizations) during last 07 (seven) years, ending last day of month previous to the one in which tender is invited:</p> <p>(i) Three similar works each costing not less than the amount equal to 30% of advertised value of the tender, or</p> <p>(ii) Two similar works each costing not less than the amount equal to 40% of advertised value of the tender, or</p> <p>(iii) One similar work each costing not less than the amount equal to 60% of advertised value of the tender.</p> <p>(b) (1) In case of tenders for composite works (e.g. works involving more than one distinct</p>

	<p>component, such as Civil Engineering works, S&T works, Electrical works, OHE works etc. and in the case of major bridges – substructure, superstructure etc.), tenderer must have successfully completed or substantially completed any one of the following categories of work(s) during last 07(seven) years, ending last day of month previous to the one in which tender is invited:</p> <ul style="list-style-type: none"> (i) Three similar works each costing not less than the amount equal to 30% of advertised value of each component of tender, or (ii) Two similar works each costing not less than the amount equal to 40% of advertised value of each component of tender, or (iii) One similar work each costing not less than the amount equal to 60% of advertised value of each component of tender. <p>Note for b (1): Separate completed works of minimum required values shall also be considered for fulfillment of technical eligibility criteria for different components.</p> <p>(b) (2) In such cases, what constitutes a component in a composite work shall be clearly pre-defined with estimated tender cost of it, as part of the tender documents without any ambiguity.</p> <p>(b) (3) To evaluate the technical eligibility of tenderer, only components of work as stipulated in tender documents for evaluation of technical eligibility, shall be considered. The scope of work covered in other remaining components shall be either executed by tenderer himself if he has work experience as mentioned in clause 2.3.3(a) (ii) or through subcontractor fulfilling the requirements as per clause 2.3.3 or jointly i.e., partly himself and remaining through subcontractor, with prior approval of Chief Engineer in writing.</p> <p style="text-align: center;"><i>No sub contract is allowed without the prior approval of RailTel.</i></p> <p>Note for Technical Eligibility Criteria:</p> <p>Work experience certificate from private individual shall not be considered. However, in addition to work experience certificates issued by any Govt. Organization, work experience certificate issued by Public listed company having average annual turnover of Rs. 500 crore and above in last 3 financial years excluding the current financial year, listed on National Stock Exchange or Bombay Stock Exchange, incorporated/ registered atleast 5 years prior to the date of closing of tender, shall also be considered provided the work experience certificate has been issued by a person authorized by the Public listed company to issue such certificates.</p> <p>In case tenderer submits work experience certificate issued by public listed company, the tenderer shall also submit alongwith work experience certificate, the relevant copy of work order, bill of quantities, bill wise details of payment received duly certified by Chartered Accountant, TDS certificates for all payments received and copy of final /last bill paid by company in support of above work experience certificate.</p>
(c)	<u>Similar Nature of Work and Components of work in case of composite work:</u>
	NIL
(c)(i)	Similar Nature of Work (in case of Single similar nature of work):
	<p><u>Definition of Similar Nature of Work:</u> Any Civil Engineering Work .</p> <p>Note- Tenderer may be required to submit the schedule of those works, Completion/Performance Certificates of which have been submitted by him/her in support of 30/40/60% (as the case may be) criterion of similar nature of work.</p>

(c)(ii)	Components of work in case of composite work. (NOT APPLICABLE IN THIS TENDER)			
	Type of component	Value of Component (Rs.)	Technical Eligibility	Similar Nature of work
	(A).....	Rs.....Cr.	By tenderer or its constituent member in case of JV as per clause 2.3.2 (A) (v) (b) (i) and 2.3.2 (A) (xii). Technical eligibility for this component will be considered for tender evaluation.
	(B).....	Rs.....Cr.	By tenderer or its constituent member in case of JV as per clause 2.3.2 (A) (v) (b) (i) and 2.3.2 (A) (xii). Technical eligibility for this component will be considered for tender evaluation.
	(C).....	Rs.....Cr.	Either by tenderer or its constituent member in case of JV or by Sub-contractor as per clause 2.3.2 (A) (v) (b) (iii). Technical eligibility for this component will be considered for tender evaluation.
	(D)	Rs..... Cr.	Either by tenderer or its constituent member in case of JV or by Sub-contractor as per clause 2.3.2 (A) (v) (b) (iii). Technical eligibility for this component will be considered for tender evaluation.
	(E).....	Rs.....Cr.	For this component, work covered into this component shall either be executed by tenderer himself if he has a work experience as per para 2.3.3 (a) (ii) or through sub-contractor fulfilling the requirement as per clause 2.3.3 or jointly i.e. partly himself and remaining through sub-contractor, with prior approval of ED/RP in writing. For this component, technical Eligibility will not be considered in tender evaluation and the documents of sub contractor need not be submitted alongwith tender. The contractor will engage an eligible sub contractor after

		award of contract with the approval of ED/RP in writing.	
	<p>Note:</p> <p>In case tenderer (either for himself or his sub-contractor) cites a single completed work towards fulfilling technical eligibility for more than one component as such work may fulfil criteria of 'similar nature of work' for more than one component. In such a case, technical eligibility for each component shall be arrived at by applying specified % for that component to the combined advertised value of all such components whose technical eligibility is proposed to be fulfilled by such work (instead of advertised value of only that component).</p> <p>Example:</p> <p>Value of component B: Rs. 20 Cr</p> <p>Value of component C: Rs. 5 Cr</p> <p>Then minimum value of a single completed work involving similar nature works for both component B and component C, required to qualify the technical eligibility criteria shall be as under:</p> <p>30%/40%/60% of Rs. 25 Cr (=20 Cr + 5 Cr) for Component B</p> <p>35% of Rs. 25 Cr (=20 Cr + 5 Cr) for component C</p>		
(d)	The following will be applicable in evaluating the eligibility:		
(i)	Similar nature of work physically completed within the qualifying period i.e., the last Seven years ending last day of month previous to the one in which tender is invited (even though the work might have commenced before the qualifying period) should only be considered in evaluating the eligibility criteria under clause 2.3.2 (A) (v) and (b) (i).		
(ii)	<p>In the case of composite works involving combination of different works, even separate completed works of required value should be considered while evaluating the eligibility criteria.</p> <p>For example, in a tender for bridge work where similar nature of work has been defined as bridge work with pile foundation and PSC superstructure, a tenderer, who had completed bridge work with pile foundation of value at least equal to 30%/40%/60% (as the case may be)of tender value and also has completed one bridge work with PSC superstructure of value at least equal to 30%/40%/60% (as the case may be) of the tender value, should be considered as having fulfilled the eligibility criterion of having completed single similar nature of work under clause 2.3.2 (A) (v) and (b) (i).</p>		
2.3.2	<u>Financial Eligibility Criteria:</u>		
(i)	<p>The tenderer must have minimum average annual contractual turnover of V/N or 'V' whichever is less; where</p> <p>V= Advertised value of the tender in crores of Rupees</p> <p>N= Number of years prescribed for completion of work for which bids have been invited.</p> <p>The average annual contractual turnover shall be calculated as an average of "total contractual payments" in the previous three financial years, as per the audited balance sheet. However, in case balance sheet of the previous year is yet to be prepared/ audited,</p>		

	<p>the audited balance sheet of the fourth previous year shall be considered for calculating average annual contractual turnover.</p> <p>The tenderers shall submit requisite information as per Annexure-I, along with copies of Audited Balance Sheets duly certified by the Chartered Accountant/ Certificate from Chartered Accountant duly supported by Audited Balance Sheet.</p> <p>(Ref: RB letter No. 2022/CE-I/CT/GCC-2022/Policy dt. 14.07.2022: Advance Correction Slip No. 1)</p>
(ii)	<p>For judging the technical eligibility, only those works which had been executed for any Government Organization shall be considered and the tenderer(s) will submit the certificate to this effect from the Officer concerned duly signed under the official seal. <u>It should be noted that credentials for the judging technical eligibility works executed for Private Individual/Private Organization shall not be considered.</u></p> <p>However for judging technical eligibility, in addition to credentials issued by any Government Organization, credentials issued by Public listed company having average annual turn over of Rs 500 crore and above in last 3 financial years excluding the current financial year, listed on National Stock Exchange or Bombay Stock Exchange, incorporated/registered atleast 5 years prior to the date of opening of tender shall also be considered provided the work experience certificate has been issued by a person authorized by the Public listed company to issue such certificates.</p> <p>In case tenderer submits credentials issued by public listed company, the tenderer shall also submit alongwith the relevant copy of work order, bill of quantities, bill wise details of payment received duly certified by Chartered Accountant, TDS certificates for all payments received and copy of final/last bill paid by company shall be enclosed in support of above.</p> <p>Completion Certificate/Experience Certificate issued by Competent Authority in favour of tenderer duly stating Name & Final cost of the Work, Date of Completion etc. as per Annexure –L must be uploaded alongwith the offer.</p>
(iii)	<p>Value of a completed work done by a Member in an earlier JV shall be reckoned only to the extent of the concerned member's share in that JV for the purpose of satisfying his/her compliance to the above mentioned technical / financial eligibility criteria in the tender under consideration.</p> <p>NOTE:- RCIL may at its discretion invite the tenderer for online verification of Form 26AS, whenever considered necessary.</p>
(iv)	<p>If a tenderer(s) has completed a work of similar nature where cement and steel was issued by the Department free of cost, tenderer(s) must upload the completion certificate indicating cost of these materials and total cost of the work (including cost of cement/steel) shall be considered to decide eligibility or otherwise.</p>
(v)	<p>The list of personnel / organization on hand and proposed to be engaged for the tendered work. Similarly list of Plant & Machinery available on hand and proposed to be inducted and hired for the tendered work.</p>
(vi)	<p>Tenderer(s) has to satisfy the eligibility criteria for technical capability and competence as well as for financial capacity and organizational resources.</p>
(vii)	<p>If the tenderer(s) is a JV, each partner of JV should have good credentials and the JV should meet the technical and financial eligibility criteria as per the guide lines given in Annexure K & K-1.</p>
(viii)	<p>If the tenderer(s) is a Partnership Firm, the conditions and the technical & financial eligibility criteria will be applicable as per guidelines given in Annexure K-2.</p>
(ix)	<p>Bid Capacity: Applicable for tender value more than Rs 20 Crore. (Not Applicable)</p>

For tenders having advertised value more than Rs 20 crore wherein eligibility criteria includes bid capacity also, the tenderer will be qualified only if its available bid capacity is equal to or more than the total bid value of the present tender. The available bid capacity shall be calculated as under:

$$\text{Available Bid Capacity} = [A \times N \times 2] - 0.33 \times N \times B$$

Where,

A = Maximum value of construction works executed and payment received in any one of the previous three financial years or the current financial year (up to date of inviting tender), taking into account the completed as well as works in progress.

N = Number of years prescribed for completion of work for which bids has been invited.

B = Value of existing commitments and balance amount of ongoing works with the tenderer as on date one month prior to the tender closing date to be completed in next 'N' years.

Note:

- (a) The Tenderer(s) shall furnish the details of -
 - (i) Maximum value of construction works executed and payment received in any one of the previous three financial years or the current financial year (up to date of inviting tender) for calculating A, and
 - (ii) Existing commitments and balance amount of ongoing works with tenderer as per the prescribed proforma of Railway for statement of all works in progress and also the works which are awarded to tenderer but yet not started upto the date of inviting of tender for calculating B. In case of no works in hand, a 'NIL' statement should be furnished.
The submitted details for (i) and (ii) above should be duly verified by Chartered Accountant.
- (b) In case if a bidder is JV, the tenderer(s) must furnish the details of
 - (i) Maximum value of construction works executed and payment received in any one of the previous three financial years or the current financial year (up to date of inviting tender) by each member of JV for calculating A, and
 - (ii) Existing commitments and balance amount of ongoing works with each member of JV either in individual capacity or as a member of other JV as per the prescribed proforma of Railway for statement of all works in progress and also the works which are awarded to each member of JV either in individual capacity or as a member of other JV but yet not started upto the date of inviting of tender for calculating B. In case of no works in hand, a 'NIL' statement should be furnished.
The submitted details for (i) and (ii) above should be duly verified by Chartered Accountant.
- (c) Value of a completed work/work in progress/work awarded but yet not started for a Member in an earlier JV shall be reckoned only to the extent of the concerned member's share in that JV for the purpose of satisfying his/her compliance to the above mentioned bid capacity in the tender under consideration.
- (d) The arithmetic sum of individual "bid capacity" of all the members shall be taken as JV's "bid capacity".
- (e) In case, the tenderer/s failed to submit the above statement along with offer, their/his offer shall be considered as incomplete and will be rejected summarily.
- (f) The available bid capacity of tenderer shall be assessed based on the details submitted by the tenderer. In case, the available bid capacity is lesser than estimated

	<p>cost of work put to tender, his offer shall not be considered even if he has been found eligible in other eligibility criteria/tender requirement. (Ref: As per GCC April, 2022)</p>
(x)	<p>No Technical and Financial credentials are required for tenders having value up to Rs 50 lakh.</p>
(xi)	<p>Credentials if submitted in foreign currency shall be converted into Indian currency i.e., Indian Rupee as under:</p> <p>The conversion rate of US Dollars into Rupees shall be the representative exchange rates published by the Reserve Bank of India for the relevant date. Where, relevant date shall be as on the last day of month previous to the one in which tender is invited. In case of any other currency, the same shall first be converted to US Dollars as on the last day of month previous to the one in which tender is invited, and the amount so derived in US Dollars shall be converted into Rupees at the aforesaid rate. The conversion rate of such currencies shall be the representative exchange rates published by the International Monetary Fund for the relevant date.</p>
(xii)	<p>[Explanation for clause 2.3 - Eligibility Criteria:</p> <ol style="list-style-type: none"> 1. In case a work is started prior to 07 (seven) years, ending last day of month previous to the one in which tender is invited, but completed in last 07 (seven) years, ending last day of month previous to the one in which tender is invited, the completed work shall be considered for fulfillment of credentials. 2. If a work is physically completed and completion certificate to this extent is issued by the concerned organization but final bill is pending, such work shall be considered for fulfillment of credentials. 3. If a part or a component of work is completed but the overall scope of contract is not completed, this work shall not be considered for fulfillment of technical credentials even if the cost of part completed work/component is more than required for fulfillment of credentials. 4. In case a work is considered similar in nature for fulfillment of technical credentials, the overall cost of that work including PVC amount if any shall be considered and no separate evaluation for each component of that work shall be made to decide eligibility. 5. The value of final bill including PVC amount-if paid, or otherwise in case final bill is pending the contract cost in last approved variation statement plus PVC amount paid or cumulative amount paid up to last on-account bill including PVC amount and statutory deductions whichever is less, shall be considered as the completion cost of work. 6. In case of newly formed partnership firm, the credentials of individual partners from previous propriety firm(s) or dissolved previous partnership firm(s) or split previous partnership firm(s), shall be considered only to the extent of their share in previous entity on the date of dissolution / split and their share in newly formed partnership firm. For example, a partner A had 30% share in previous entity and his share in present partnership firm is 20%. In the present tender under consideration, the credentials of partner A will be considered to the extent of 0.3×0.2 value of the work done in the previous entity. For this purpose, the tenderer shall submit along with his bid all the relevant documents which include copy of previous partnership deed(s), dissolution deed(s) and proof of surrender of PAN No.(s) in case of dissolution of partnership firm(s) etc. 7. In case of existing partnership firm, if any one or more partners quit the partnership firm, the credentials of remaining partnership firm shall be re-worked out i.e., the quitting partner(s) shall take away his credentials to the extent of his share on the date of quitting

	<p>the partnership firm (e.g. in a partnership firm of partners A, B & C having share 30%, 30% & 40% respectively and credentials of Rs 10 crore; in case partner C quits the firm, the credentials of this partnership firm shall remain as Rs 6 crore). For this purpose, the tenderer shall submit along with his bid all the relevant documents which include copy of previous partnership deed(s), dissolution deed(s) and proof of surrender of PAN No.(s) in case of dissolution of partnership firm(s) etc.</p> <p>8. In case of existing partnership firm if any other partner(s) joins the firm, the credentials of partnership firm shall get enhanced to the extent of credentials of newly added partner(s) on the same principles as mentioned in item 6 above. For this purpose, the tenderer shall submit along with his bid all the relevant documents which include copy of previous partnership deeds, dissolution/splitting deeds and proof of surrender of PAN No.(s) in case of dissolution of partnership firm etc.</p> <p>9. Any partner in a partnership firm cannot use or claim his credentials in any other firm without leaving the partnership firm i.e., In a partnership firm of A&B partners, A or B partner cannot use credentials of partnership firm of A&B partners in any other partnership firm or propriety firm without leaving partnership firm of A&B partners.</p> <p>10. In case a partner in a partnership firm is replaced due to succession as per succession law, the proportion of credentials of the previous partner will be passed on to the successor.</p> <p>11. If the percentage share among partners of a partnership firm is changed, but the partners remain the same, the credentials of the firm before such modification in the share will continue to be considered for the firm as it is without any change in their value. Further, in case a partner of partnership firm retires without taking away any credentials from the firm, the credentials of partnership firm shall remain the same as it is without any change in their value.</p> <p>12. In a partnership firm “AB” of A&B partners, in case A also works as propriety firm “P” or partner in some other partnership firm “AX”, credentials of A in propriety firm “P” or in other partnership firm “AX” earned after the date of becoming a partner of the firm AB shall not be added in partnership firm AB.</p> <p>13. In case a tenderer is LLP, the credentials of tenderer shall be worked out on above lines similar to a partnership firm.</p> <p>14. In case company A is merged with company B, then company B would get the credentials of company A also.]</p> <p>15. In case of change in partners of a partnership firm, the share of partners in credentials of a partnership firm shall be considered as per share of partners on the Actual date of completion of the work. In case name and share of partners is not mentioned in the completion certificate, share of partners in the credentials shall be considered as per share of partners on the Actual date of completion of the work, as derived from the partnership deed(s).</p>
	<p>Note:-</p> <p>A. In respect of GCC-2022, clause-10, Explanation Note No. 7, following is clarified: -</p> <ol style="list-style-type: none"> i. In case of any change in the partners of firm during last 07 (seven) years, ending last day of the month previous to the one in which tender is invited, the share of credentials for the purpose of Technical Eligibility will be considered as per the share of partners as on the date of completion of work. ii. In case of any change in partners of firm during last 03 (three) financial years and current financial year upto the date of inviting of the tender, the share of credentials of any partners will be considered in the proportion of partners on the date of receipt of contractual payments.

	<p>B. In case of new partnership firm, following is clarified in respect of clarification of credentials of individual partners from previous partnership firm(s) or previous dissolved partnership firm(s) or previous split partnership firm(s):-</p> <p>i. For the purpose of Technical Eligibility, the credentials of individual partners from the previous dissolved / split previous partnership firm (s) shall be considered in proportion as on the date of completion of work.</p> <p>ii. For the purpose of Financial Eligibility, the proportion of individual partners from the previous dissolved / splitted previous Partnership firm (s) shall be considered in the proportion as on the date of receipt of contractual payments.</p> <p>In such cases, following documents are required to be submitted alongwith bid:-</p> <p>(i) Copy of previous Partnership Deed(s).</p> <p>(ii) Copy of previous Dissolution Deed(s) of previous partnership deed(s).</p> <p>(iii) Proof of surrender of PAN No(s) (in case of dissolution of partnership firm).</p> <p>➤ Relevant Annexures K-3 & K-4 are to be submitted by the tenderer alongwith the bid.</p>
2.3.3	<p>No sub contracting is allowed in this work without prior approval of RailTel</p>
2.3.4	<p>Public Procurement (Preference to Make in India):- (Authority:- As per Railway Board letter No. 2015/RS(G)/779/5, dated 01.02.2018, No. 2017/Trans/01/Policy/Pt-S, dated 28.03.2018, Railway Board letter no. 2020/RS(G)/779/2, dated 12.06.2020 and Ministry of Commerce and Industry letter no. P-45021/2/2017-B.E.-II, dated 15.06.2017).</p>
2.3.4.1	<p>This tender complies with Public Procurement Policy order 2017 dated 15.06.17 and (Revision), dated 04.06.2020 or latest.</p>
2.3.4.2	<p>Following provisions will be applicable for item to be procured under Public Procurement (preference to Make in India) order 2017 dated 15.06.2017 and 04.06.2020 or latest.</p> <p>A) Local content: the minimum local content shall be 50% or as indicated in the tender enquiry.</p> <p>B) Margin of purchase preference: The margin or purchase preference is 20%.</p> <p>C) Fee for complaint: Fee for filling a complaint under the order shall be Rs. 10,000/- per case. The complaint shall be filed in the office of the ED/RP. The fee shall be deposited with the office of the ED/RP Delhi.</p> <p>D) Class-I local supplier: Means a supplier or service provider, whose goods, services or works offered for procurement, has local content equal to or more than 50% as defined under this order.</p> <p>E) Class-II local supplier: Means a supplier or service provider, whose goods, services or works offered for procurement has local content more than 20% but less than 50% as defined under this order.</p>
2.3.4.3	<p><u>Verification of local content:</u></p> <p>A) The 'Class-I local supplier' / 'Class-II local supplier' at the time of tender, bidding or solicitation shall be required to indicate percentage of local content and provide self-certification that the item offered meets the local content requirement for 'Class-I local supplier' / 'Class-II local supplier', as the case may be. They shall also given details of the location (s) at which the local value addition is made.</p>

	<p>B) In case of procurement for a value in excess of Rs. 10 Crores, the 'Class-I local supplier' / 'Class-II local supplier' shall be required to provide a certificate from the statutory auditor or cost auditor of the company (in the case of companies) or form a practicing cost accountant or practicing chartered accountant (in respect of suppliers other than companies) giving the percentage of local content.</p> <p>C) False declarations will be in breach of the code of integrity under Rule 175 (1) (i) (h) of the General Financial Rules for which a bidder or its successors can be debarred for up to two years as per Rule 151 (iii) of the General Finance Rules along with such other actions as may be permissible under law.</p> <p>D) A supplier who has been debarred by any procuring entity for violation of this Order shall not be eligible for preference under this Order for procurement by any other procuring entity for the duration of the debarment.</p> <p>E) Debarment of bidders: In respect of procuring entities other than the one which has carried out the debarment, the debarment takes effect prospectively from the date of uploading on the websites(s) so that ongoing procurements are not disrupted.</p>
2.3.4.4	<p><u>Requirement of Purchase preference:</u></p> <p>b) Subject to the provisions of this Order and to any specific instructions issued by the Nodal Ministry or in pursuance of this Order, purchase preference shall be given to 'Class-I local suppliers' in all procurements under taken by procuring entities in the manner specified hereunder:</p> <p>b) In the procurements of goods or works which are not covered by para 3(b) above and which are divisible in nature, the 'Class-I local supplier' shall get purchase preference over 'Class-II local supplier' as well as 'Non-Local supplier' as per following procedure:-</p> <p>i) Among all qualified bids, the lowest bid will be termed as L1. If L1 is 'Class-I local supplier', the contract for full quantity will be awarded to L1.</p> <p>ii) If L1 bid is not a 'Class-I local supplier', 50% of the order quantity shall be awarded to L1. Thereafter, the lowest bidder among the 'Class-I local suppliers' will be invited to match the L1 price for the remaining 50% quantity subject to the Class-I local supplier's quoted price falling within the margin of purchase preference and contract for that quantity shall be awarded to such 'Class-I local supplier' subject to matching the L1 price. In case such lowest eligible 'Class-I local supplier' fails to match the L1 price or accepts less than the offered quantity, the next higher 'Class-I local supplier' within the margin of purchase preference shall be invited to match the L1 price for remaining quantity and so on, and contract shall be awarded accordingly. In case some quantity is still left uncovered on 'Class-I local suppliers', then such balance quantity may also be ordered on the L1 bidder.</p> <p>c) In procurements of goods or works, which are covered by para 3(b) above and which are not divisible in nature, and in procurement of services where the bid is evaluated on price alone, the 'Class-I local supplier' shall get purchase preference over 'Class-II local Supplier' as well as 'Non-local supplier', as per following procedure:</p> <p>i) Among all qualified bids, the lowest bid will be termed as L1. If L1 is 'Class-I local supplier', the contract will be awarded to L1.</p> <p>ii) If L1 is not 'Class-I local supplier', the lowest bidder among the 'Class-I local suppliers', will be invited to match the L1 price subject to 'Class-I local supplier's quoted price</p>

	<p>falling within the margin of purchase preference, and the contract shall be awarded to such 'Class-I local supplier' subject to matching the L1 price.</p> <p>iii) In case such lowest eligible 'Class-I local supplier' fails to match the L1 price, the 'Class-I local supplier' with the next higher bid within the margin of purchase preference shall be invited to match the L1 price and so on and contract shall be awarded accordingly. In case none of the 'Class-I local suppliers' within the margin of purchase preference matches the L1 price, then the contract may be awarded to the L1 bidder.</p> <p>d) "Class-II local supplier' will not get purchase preference in any procurement, undertaken by procuring entities.</p>
2.4	<u>CONSTITUTION OF THE FIRM:</u>
2.4.1	<p>(g) The tenderer shall clearly specify whether the tender is submitted on his own (Proprietary Firm) or on behalf of a Partnership Firm / Company / Joint Venture (JV) / Registered Society / Registered Trust / HUF etc. The tenderer(s) shall enclose the attested copies of the constitution of their concern, and copy of PAN Card along with their tender. Tender Documents in such cases are to be signed by such persons as may be legally competent to sign them on behalf of the firm, company, association, trust or society, as the case may be.</p> <p>(ii) Following documents shall be submitted by the tenderer:</p>
(A)	<u>Sole Proprietorship firm:</u>
	<p>(Undertaking as per Annexure O-1)</p> <p>Undertaking (An Undertaking that the company is not black listed or debarred by RCIL/Railway or any other Ministry/Department of Govt. of India from participation in tender on the date of opening of bids, either in individual capacity or as a member of the partnership firm or JV in which the company was/is a partner/member. Concealment/wrong information in regard to above shall make the contract liable for determination under clause 62 of the General Conditions of contract) may be given. If not given</p> <p>As per para 14(iii) of GCC-2022, If it is NOT mentioned in the submitted tender that tender is being submitted on behalf of a Sole Proprietorship firm/Partnership firm/Joint Venture/Registered Company etc., then the tender shall be treated as having been submitted by the individual who has signed the tender.</p>
(B)	<u>Partnership Firm:</u>
	<p><u>For All Type of Works Tenders.</u></p> <p>The tenderer shall clearly specify that the tender is submitted on behalf of a partnership firm. The following documents shall be submitted by the partnership firm, with the tender:</p> <ol style="list-style-type: none"> 1. A Notarised copy of the Partnership Deed. 2. Document(s) in support of Registration of firm with Registrar/Sub-Registrar of firms viz. Certificate of registration and copy of Register of firm (Form No. may vary from State to State) (as applicable) etc. issued by Registrar of firms. 3. A Notarised or Registered Power of Attorney in favour of the individual signing the tender document and create liability against the Firm. (Standard Performa as per Annexure O-2) 4. An undertaking by all partners of the partnership firm that they are not blacklisted or debarred by RCIL/Railway or any other Ministry / Department of the Govt. of India from participation in tenders / contracts as on the date of opening of bids, either in their individual capacity or in any firm in which they were / are partners. Concealment / wrong information in regard to above shall make the contract liable for determination under Clause 62 of the General Conditions of Contract. <p>Note: Authorisation given in POA only will be considered irrespective of any authorization that may have given in Partnership Deed. In case of non-submission of POA or invalid POA, offer is liable to be rejected.</p>
(C)	<u>Joint Venture (JV)</u>

	If the tender is uploaded on behalf of a JV, the tenderer must upload the following
(1)	A copy of Memorandum of Understanding (MoU) duly executed by the JV members on a stamp paper, shall be submitted by the JV alongwith the tender (Standard proforma as per Annexure K-1). The complete details of the members of the JV, their share and responsibility in the JV etc. particularly with reference to financial, technical and other obligations shall be furnished in the MoU.
(2)	Notarised Power of Attorney/authorization duly executed by all JV constituents, in favour of the individual signing the tender document on behalf of the JV; and (Standard Performa as per Annexure O-3)
(3)	In addition, following documents must be upload/submit by the JV firms along with the tender:-
(i)	In case one or more of the members of the JV firms is /are partnership firm(s), following documents shall be uploaded/submitted.
(a)	(i) A Notarised copy of the Partnership Deed. (ii) Document(s) in support of registration of firm with registrar/Sub-Registrar of firms viz. Certificate of registration and copy of Register of firm (Form No. may vary from State to State) (as applicable) etc. issued by registrar of firms.
(b)	A copy of consent of all the partners or individual authorized by partnership firm, to enter into the Joint Venture Agreement on a stamp paper, (Standard Performa as per Annexure O-4)
(c)	A copy of Power of Attorney (duly Notarised or Registered) in favour of the individual to sign the MOU/JV Agreement on behalf of the partnership firm and create liability against the firm. (Standard Performa as per Annexure O-5) Note: Authorisation given in POA only will be considered irrespective of any authorization that may have given in Partnership Deed. In case of non-submission of POA or invalid POA, offer is liable to be rejected.
(ii)	In case one or more members of JV is/are Proprietary Firm or HUF, the following documents shall be uploaded/submitted: A copy of notarized affidavit on Stamp Paper declaring that he who is signing the affidavit on behalf of HUF is in the position of 'Karta' of Hindu Undivided (HUF) and he has the authority, power and consent given by other members to act on behalf of HUF. (Standard Affidavit as per Annexure O-6)
(iii)	In case one or more members of JV is/are Limited Companies, the following documents shall be submitted/uploaded:
	(i) A copy of resolutions of the Directors of the Company, permitting the company to enter into a JV agreement, (Standard Performa as per Annexure O-7)
	(ii) Copy of Memorandum of Association and Articles of Association of the Company.
	(iii) Copy of certificate of incorporation
	(iv) A copy of Authorization/copy of Power of Attorney issued by the Company (backed by the resolution of Board of Directors) in favour of the individual to sign the tender, sign MOU/JV Agreement on behalf of the company and create liability against the company (Standard Performa as per Annexure O-8).

(iv)	<p>In case one or more members of JV is/are LLP firm, the following documents shall be submitted/uploaded:</p> <ul style="list-style-type: none"> (a) A notarised copy of certificate of incorporation and LLP agreement. (b) A notarised copy of resolution of the partners of LLP, permitting the LLP to enter into a JV agreement, authorising one of the partners of LLP to sign JV MOU/agreement and such other documents required to be signed on behalf of the LLP and to create liability against the LLP and/or to do any other act on behalf of LLP (Standard proforma as per Annexure O-13) (c) A copy of authorisation/copy of power of attorney issued by the LLP (backed by resolution of partners) in favour of individual to sign the tender, to sign MOU/JV agreement on behalf of the LLP and create liability against the LLP (Standard proforma as per Annexure O-14)
(v)	<p>All the Members of JV shall certify that they are not blacklisted or debarred by RCIL/Railway or any other Ministry / Department of the Govt. of India from participation in tenders/contract on the date of opening of bids either in their individual capacity or as a member of the JV in which they were/are members.</p> <p>NOTE:- To be submitted by each constituent member of JV.</p>
(D)	<p><u>Company:</u></p>
	<p>If the tender is uploaded on behalf of a Company registered under Companies Act-2013, the tenderer must submit/upload along with the tender the following documents on or before close of uploading of tender & before opening of tender (D2):</p> <ul style="list-style-type: none"> (1) Copies of the MOA /AOA (Memorandum of Association /Article of Association) of the Company; (2) A copy of certificate of incorporation. (3) A copy of Authorization/Power of Attorney issued by the Company (backed by the resolution of Board of Directors) in favour of the individual to sign the tender on behalf of the company and create liability against the company (Standard Performa as per Annexure O-9, 10). (4) An Undertaking that the company is not black listed or debarred by RCIL/Railway or any other Ministry/Department of Govt. of India from participation in tender on the date of opening of bids, either in individual capacity or as a member of the partnership firm or JV in which the company was/is a partner/member. Concealment/wrong information in regard to above shall make the contract liable for determination under clause 62 of the General Conditions of contract.
(E)	<p>Registered Society & Registered Trust:</p>
	<p>The tenderer must upload following,</p> <ul style="list-style-type: none"> (1) copy of the certificate of registration; (2) copy of Deed of formation; and (3) A copy of Power of Attorney in favour of the individual to sign the tender documents and create liability against the Society/Trust.
F	<p>LLP (Limited Liability Partnership) Firm: If the tender is submitted on behalf of a LLP Firm registered under LLP Act-2008, the tenderer shall upload alongwith the tender-</p> <ul style="list-style-type: none"> (i) A copy of LLP Agreement, (ii) A copy of Certificate of Incorporation; and (iii) A copy of Power of Attorney/Authorization issued by the LLP in favour of the individual to sign the tender on behalf of the LLP and create liability against the LLP (Standard proforma as per Annexure O-11 & 12). (iv) An Undertaking that the LLP is not black listed or debarred by RCIL/Railway or any other Ministry/Department of Govt. of India from participation in tender on the date of opening of bids, either in individual capacity or as a member of JV in which the LLP was/is a member. Concealment/wrong information in regard to above shall make the contract liable for determination under clause 62 of the General Conditions of contract.

G	<p><u>In Case of HUF:</u></p> <p>(i) A copy of notarized affidavit on Stamp Paper declaring that he who is submitting the tender on behalf of HUF is in the position of 'Karta' of Hindu Undivided family (HUF) and he has the authority, power and consent given by other members to act on behalf of HUF (Standard proforma as per Annexure O-15).</p> <p>(ii) An undertaking that the HUF is not blacklisted or debarred by RCIL/Railway or any other Ministry / Department of Govt. of India from participation in tender on the date of opening of bids, either in individual capacity or as a member of the partnership firm or JV in which HUF was / is a partner/member. Concealment / wrong information in regard to above shall make the contract liable for determination under Clause 62 of the General Conditions of Contract.</p>
2.4.1.1	<ul style="list-style-type: none"> • After opening of the tender, any document pertaining to the constitution of Sole Proprietorship Firm / Partnership Firm / Registered Company/ Registered Trust / Registered Society / HUF etc. shall be neither asked nor considered, if submitted. Further, no suo moto cognizance of any document available in public domain (i.e., on internet etc.) or in RCIL record/office files etc. will be taken for consideration of the tender, if no such mention is available in tender offer submitted. • No change in the constitution of the <i>firm/JV/sole proprietorship/partnership firm/company/ Registered Trust/Registered Society/LLP/HUF</i> shall be permitted after opening of the tender except where necessitated due to the operation of succession laws etc. in which case prior permission should be taken from RCIL and in any case the minimum eligibility criteria should not get vitiated. • The RCIL will not be bound by any change in the composition of the firm made subsequent to the submission of tender. RCIL may, however, recognize such power of attorney and changes after obtaining proper legal advice, the cost of which will be chargeable to the Contractor. <p>Note:</p> <ol style="list-style-type: none"> 1. If all the requisite documents pertaining to the constitution of the firm/JV/sole proprietorship/partnership firm/company/ Registered Trust/Registered Society/ LLP/HUF etc., as specified in clause 2.4.1 above, are not submitted, offer will be considered as incomplete and shall be summarily rejected. 2. Standard Proforma/Affidavit O-1 to O-15 are given as per Constitution of Firm requirement in respective clause of Sole Proprietorship firm/Partnership firm/JV/Company Registered Trust/Registered Society/LLP/HUF for guidance purpose.
2.4.2	<p>The tenderer whether sole proprietor / a company or a partnership firm / joint venture (JV) / registered society / registered trust / HUF etc if they want to act through agent or individual partner(s), should submit along with the tender, a copy of power of attorney duly stamped and authenticated by a Notary Public or by Magistrate in favour of the specific person whether he/they be partner(s) of the firm or any other person specifically authorizing him/them to submit the tender, sign the agreement, receive money, co-ordinate measurements through contractor's authorized engineer, witness measurements, sign measurement books, compromise, settle, relinquish any claim(s) preferred by the firm and sign "No Claim Certificate" and refer all or any disputes to arbitration. The above power of attorney shall be submitted even if such specific person is authorized for above purposes through partnership deed / Memorandum of Understanding / Article of Association or such other document, failing which tender is liable to be rejected.</p>
2.4.3	<p>Instructions for bidders from a country which shares a land border with India</p>
	<p>I Any bidder from a country which shares a land border with India will be eligible to bid in this tender only if the bidder is registered with the Competent Authority.</p>

II "Bidder" (including the term 'tenderer', 'consultant' or 'service provider' in certain contexts) means any person or firm or company, including any member of a joint venture every artificial juridical person not falling in any of the descriptions of bidders stated herein before, including any agency branch or office controlled by such person, participating in a procurement process.

III "Bidder from a country which shares a land border with India" for the purpose of this Order means:-

- a) An entity incorporated, established or registered in such a country; or
- b) A subsidiary of an entity incorporated, established or registered in such a country; or
- c) An entity substantially controlled through entities incorporated, established or registered in such a country; or
- d) An entity whose beneficial owner is situated in such a country; or
- e) An Indian (or other) agent of such an entity; or
- f) A natural person who is a citizen of such a country; or
- g) A joint venture where any member of the joint venture falls under any of the above.

IV The beneficial owner for the purpose of (III) above will be as under:

1. In case of a company or Limited Liability Partnership, the beneficial owner is the natural person(s), who, whether acting alone or together, or through one or more juridical person(s), has a controlling ownership interest or who exercises control through other means.

Explanation-

- a) "Controlling ownership interest" means ownership of, or entitlement to, more than twenty-five per cent of shares or capital or profits of the company;
 - b) "Control" shall include the right to appoint majority of the directors or to control the management or policy decisions, including by virtue of their shareholding or management rights or shareholders agreements or voting agreements;
2. In case of a partnership firm, the beneficial owner is the natural person(s) who, whether acting alone or together, or through one or more juridical person, has ownership of entitlement to more than fifteen percent of capital or profits of the partnership;
 3. In case of an unincorporated association or body of individual, the beneficial owner is the natural person(s), who, whether acting alone or together, or through one or more juridical person, has ownership of or entitlement to more than fifteen percent of the property or capital or profits of such association or body of individuals;
 4. Where no natural person is identified under (1) or (2) or (3) above, the beneficial owner is the relevant natural person who holds the position of senior management official;
 5. In case of a trust, the identification of beneficial owner(s) shall include identification of the author of the trust, the trustee, the beneficiaries with fifteen percent or more interest in the trust and any other natural person exercising ultimate effective control over the trust through a chain of control or ownership.

V An agent is a person employed to do any act for another, or to represent another in dealings with third person.

VI The successful bidder shall not be allowed to sub-contract works to any contractor from a country which shares a land border with India unless such contractor is registered with the Competent Authority.

	Note:- Mandatory certificate as per Annexure–S to be submitted by tenderer alongwith the tender documents
2.5	<u>INCOME TAX DEDUCTION:</u>
2.5.1	As per Income Tax Act, Tax will be deducted for sums paid for carrying out the work under this contract. In case of supply contract for ballast, deduction of 2% (Two percent) Income tax will be made for the sums paid for labour portion only (i.e., loading, unloading, stacking, measurement and laying etc.).
2.5.2	<u>Labour Cess:</u> 1% labour cess shall be deducted from each RA bill to be deposited with concerned labour Commissioner/State Govt.
3.0	<u>EARNEST MONEY</u>
3.1	A. EMD will be submitted by bidder on IREPS. <ul style="list-style-type: none"> i. Any firm recognized by Department of Industrial Policy and Promotion (DIPP) as 'Startups' shall be exempted from payment of earnest money deposit detailed above. ii. Eligible MSEs are exempted from EMD. No other exemption will be given. iii. 100% Govt owned PSUs shall be exempt form payment of earnest money deposit detailed above. iv. Labour Co-operative Societies shall deposit only 50% of above Earnest Money.
3.1.1	The tenderer(s) shall keep the offer open for a period of 60 days for the tender value upto Rs.10 cr and tender value more than Rs.10 cr from the date of opening of the tender in which period tenderer(s) cannot withdraw his/their offer subject to period being extended further, if required, by mutual agreement from time to time. It is understood that the Tender Documents have been sold/issued to the tenderer(s) and tenderer(s) is/are being permitted to in consideration of stipulation on his/their part that after submitting his/their offer, he/they will not resile from his/their offer or modify the terms and conditions thereof in a manner not acceptable to RCIL. Should the tenderer(s) fail to observe/to comply with the foregoing stipulation or fail to undertake the contract after acceptance of his/their tender, the entire amount deposited as Earnest Money for the due performance of the stipulation and to keep the offer open for the specified period, shall be forfeited to the RCIL . RCIL If the tender is accepted, the amount of all Earnest Money will be retained as part Security Deposit for due and faithful fulfilment of the contract. The Earnest Money of unsuccessful tenderer(s) will, save as herein before provided be returned to the unsuccessful tenderer(s) within a reasonable time, but RCIL shall not be responsible for any loss or depreciation that may happen to the Earnest Money for the due performance of the stipulation and to keep the offer open for the period stipulated in the Tender Documents while in RCIL possession nor will be liable to pay interest thereon.
3.2	The Earnest Money of the requisite amount referred to in Clause 3.1 above is required to be deposited through e-gate way (applicable where option B of clause 3.1 is indicated on IREPS). Note
	(i) Tenders uploaded/submitted with Earnest Money in any form other than those specified above shall not be considered.
	(ii) Any request for recovery from outstanding bills for Earnest Money against present tender will not, under any circumstances, be entertained
	(iii) No interest will be payable on the Earnest Money and Security Deposit or the amount payable to the contractor under the contract.
4.0	<u>ACCEPTANCE OF TENDER</u>

4.1	(i) IF THE TENDERER (S) DELIBERATELY GIVES WRONG INFORMATION/CREDENTIALS/DOCUMENTS IN HIS/THEIR TENDERS AND THEREBY CREATE(S) CIRCUMSTANCES FOR ACCEPTANCE OF HIS/THEIR TENDER, RCIL RESERVES THE RIGHT TO REJECT SUCH TENDER AT ANY STAGE, BESIDES, SHALL SUSPEND THE BUSINESS upto FIVE YEARS”.
	(ii) If on verification of credentials, at the evaluation stage, it is found that the tenderer has submitted forged/fake documents in support of his offer, his Earnest Money Deposit shall be forfeited besides suspending business with him/them upto five years.
4.2	The authority for acceptance of the tenders rests with ED/RP or any other official of RCIL as the case may be who does not undertake to assign reasons for declining to consider any particular tender or tenders. He also reserves the right to accept the tender in whole or in part or to divide the tender amongst more than one tenderer if deemed necessary.
4.3	The successful tenderer/s shall be required to execute an agreement with the ED/RP for carrying out of the work as per agreed conditions. The cost of stamp for the agreement will be borne by the RCIL.
4.3.1	The contractors operations and proceedings in connection with the works shall at all times be conducted during the continuance of contract in accordance with the laws, ordinance, rules and regulations for the time being in force and the contractor shall further observe and comply with the bye-laws and regulations of the Govt. of India, State Govt. and of Municipal & other authorities having jurisdiction in connection with the works or site over operations such as these are carried out by the contractor/s and shall give all notice required by such bye-laws and regulations. The Hospital and medical regulations in force for the time being shall also be complied with by the contractor/s and his workmen.
4.3.2	The contractor shall be responsible for the observance of the rules and regulations under the mines act and mineral rules and Indian Metallurgical rules and regulations of State/Central Govt. concerned as amended from time to time.
4.3.3	Contractor shall at all times keep the RCIL administration indemnified against all penalties that may be imposed by the Govt. of India or State Govt. for infringements or any of the clauses of the mines act and rules made there under in respect of quarries from which the ballast for these works is procured.
4.4	The tenderer/s shall not increase his/their rate in case the RCIL Administration negotiates for reduction of rates. Such negotiations shall not amount to cancellation or withdrawal of the original offer and rates originally quoted will be binding on the tenderer/s.
4.5	The tenderer/s shall submit an analysis of rates if called upon to do so
4.6	Non-compliance with any of the conditions set forth herein is liable to result in the tender being rejected.
4.7	<u>Variation in quantity</u>
4.7.1	The tenderer/contractor will be bound to execute the additional quantities on the following terms and conditions.
4.7.1.1	<p>a. The quantity indicated in the Schedule of Requirements is the estimated quantities in respect of the work and may change depending on the detailed survey/system design. On this and other developments, the purchaser may exercise the option of increase / decrease of the quantity of items of Schedule of Requirements by 25% (Twenty five percent) of the value of the contract at the accepted rates within the scope of the work.</p> <p>b. Quantity may also vary beyond 25% as per the following -</p> <ul style="list-style-type: none"> • Quantity variation beyond 25% up to 40% will be 2% rebate, above 40% to 50% with 4% rebate and beyond 50% rates will be negotiated by RCIL with Contractor.

5.0	<u>Security Deposit and Performance Guarantee on Acceptance of Tender</u>
5.1	<ul style="list-style-type: none"> • The security deposit/rate of recovery/mode of recovery on acceptance of tender shall be as under: • The Earnest Money deposited by the Contractor with his tender will be retained by RCIL as part of security for the due and faithful fulfillment of the contract by the Contractor. The Security Deposit shall be 5% of the contract value. Security Deposit may be deposited by the Contractor before release of first on account bill in cash or may be recovered at the rate of 10% of the bill amount till the full Security Deposit is recovered. Provided also that in case of defaulting Contractor, the RCIL may retain any amount due for payment to the Contractor on the pending "on account bills" so that the amounts so retained (including amount guaranteed through Performance Guarantee) may not exceed 5% of the total value of the contract. • Further, in case of contracts having value equal to or more than ₹ 50 crore (Rs Fifty crore) the Security Deposit may be deposited as Bank Guarantee Bond also, issued by a scheduled bank after execution of contract documents, but before payment of 1st on account bill. Provided further that the validity of Bank Guarantee Bond shall be extended from time to time, depending upon extension of contract granted in terms of Clause 17 of the Standard General Conditions of Contract. Further, in case Security Deposit has been submitted as Term Deposit Receipt/Bank Guarantee Bond in full amount, the Earnest Money deposited by the Contractor with his tender will be returned by the RCIL. <p>Note: After the work is physically completed as certified by competent authority, Security Deposit recovered from the running bills of a Contractor can be returned to him, if he so desires, in lieu of Term Deposit Receipt/irrevocable Bank Guarantee for equivalent amount from Scheduled Bank, to be submitted by him.</p> <p>The total security deposit recoverable from a contractor including the amount of earnest money deposited with the tender as given in Clause above will not exceed the security amount recoverable at the rates mentioned above.</p> <p>The security deposit shall be forfeited whenever the Contract is rescinded. The Security Deposit unless forfeited in whole or in part according to the terms and conditions shall be released to the contractor only after the expiry of maintenance period and after passing the final bill based on 'No Claim Certificate'.</p> <p>Thus before releasing the S.D., an unconditional and un-equivocal 'No Claim Certificate' from the Contractor concerned should be obtained. The competent authority should issue the certificate regarding the expiry of the maintenance period and passing of the Final Bill based on 'No Claim Certificate'.</p>
5.1.1	<p>Refund of Security Deposit: Security Deposit shall be returned to the Contractor alongwith or after the following:</p> <ul style="list-style-type: none"> (a) Final Payment of the Contract as per clause 51. (1) of GCC, and (b) Execution of Final Supplementary Agreement or Certification by Engineer that RCIL has No Claim on Contractor, and (c) Maintenance certificate issued on expiry of the maintenance period as per clause 50.(1) of GCC, in case applicable. <p>Note :-</p> <p>The Competent Authority to issue above Maintenance Certificate shall normally be the authority who is competent to sign the contract. If this Competent Authority is of the rank lower than GM Grade, then a DGM Grade Officer (concerned with the work) should issue the certificate.</p>

	The certificate, inter alia, should mention that the work has been completed in all respects and that all the contractual obligations have been fulfilled by the Contractor and that there is no due from the Contractor to RCIL against the contract concerned.
5.1.2	Forfeiture of Security Deposit: Whenever the contract is rescinded as a whole under clause 62 (1) of GCC, the Security Deposit already with RCIL under the contract shall be forfeited. However, in case the contract is rescinded in part or parts under clause 62 (1) of GCC, the Security Deposit shall not be forfeited.
5.2	<p><u>Performance Guarantee:</u></p> <p>The successful bidder shall have to submit a performance Guarantee (PG) within 21 (twenty one) days from the date of issue of letter of acceptance (LOA). Extension of time for submission of PG beyond 21 (twenty one) days and upto 60 days from the date of issue of LOA may be given by the authority who is competent to sign the contract agreement. However, a penal interest of 15% per annum shall be charged for the delay beyond 21 (twenty one) days, i.e. from 22nd day after the date of issue of LOA. Further, if the 60th day happens to be a declared holiday in the concerned office of the RCIL, submission of PG can be accepted on the next working day. In case the contractor fails to submit the requisite PG even after 60 days from the date of issue of LOA, the contract is liable to be terminated duly forfeiting EMD and other dues, if any payable against that contract. In case contract is terminated RCIL shall be entitled to forfeit Earnest Money Deposit and other dues payable against that contract. In case a tenderer has not submitted Earnest Money Deposit on the strength of their registration as a Startup recognized by Department of Industrial Policy and Promotion (DIPP) under Ministry of Commerce and Industry, DIPP shall be informed to this effect.</p> <p>(a) The failed contractor shall be debarred from participating in re-tender for that work.</p> <p>(b) The successful bidder shall submit the performance Guarantee (PG) in any of the following forms, amounting to 10% of the contract value.</p> <p>(i) A deposit of RTGS</p> <p>(ii) Irrevocable Bank Guarantee;</p> <p>Note:- (i) The instruments as listed above will also be acceptable for Guarantees in case of mobilization advance. All the instruments mentioned in (i) to (ii) above should be in favour of RailTel Corporation of India Limited payable at Delhi.</p> <p>(ii) A separate advice of the BG will invariably be sent by the BG issuing bank to the Railtel Bank through SFMS and only after this the BG will become acceptable to Railtel. It is therefore in own interest of Bidder to obtain Railtel bank IFSC code, its branch and address and advise these particulars to the BG issuing bank and request them to send advice of BG through SFMS to the Railtel's Bank.</p> <p>(iii) Any performance security upto a value of Rs. 5 Lakhs is to be submitted through online transfer only.</p> <p>(c) A Performance Guarantee shall be submitted by the successful Bidder after the letter of acceptance has been issued, but before signing of the agreement. This PG shall be initially valid up to the stipulated date of completion plus 60 (Sixty) days beyond that. In case, the time of completion of work gets extended, the contractor shall get the validity of P G extended time for completion of work plus 60 (Sixty) days.</p> <p>i. If Railway PSUs are awarded contracts through competitive bidding (Open Tender, Special Limited Tender etc.,) the normal rule regarding submission of Performance Guarantee as applicable to other tenderer/s. shall be applicable to these PSUs.</p> <p>ii. Wherever Railway PSUs are awarded works contracts by RCIL /Railway , on Single Tender basis, they are exempted from the requirement of submitting Performance Guarantee.</p>

	<p>iii. However, in the event of failure of the Railway PSU to successfully execute the contract as per terms and conditions laid down in the Agreement, a penalty equivalent to 5% (Five Percent) of the Original value of contract would be levied.</p> <p>(d) The value of PG to be submitted by the contractor will not change for variation upto 25% (either increase or decrease) In case during the course of execution, value of the contract increases by more than 25% of the original contract value, an additional Performance Guarantee amounting to 10% (Ten percent) for the excess value over the original contract value shall be deposited by the contractor. On the other hand, if the value of Contract decreases by more than 25% of the original contract value, Performance Guarantee amounting to 10% (Ten percent) of the decrease in the contract value shall be returned to the contractor. The PG amount in excess of required PG for decrease contract value, available with RCIL, shall be returned to contractor as per their request duly safeguarding the interest of RCIL.</p> <p>(e) The Performance Guarantee (PG) shall be released after the Physical completion of the work based on the "Completion Certificate" issued by the competent authority stating that the Contractor has completed the work in all respects satisfactorily. The competent authority shall normally be the authority who is competent to sign this contract. If the competent authority is of the rank lower than GM or its equivalent, then a DGM level Officer (concerned with the work) should issue certificate. The security deposit shall, however, be released only after expiry of the maintenance period and after passing the final bill based on 'No claim certificate' from the contractor.</p> <p>(f) Whenever the contract is rescinded, the security deposit shall be forfeited and the Performance Guarantee shall be encashed and the balance work shall be got done independently without Risk and Cost of the failed contractor. The failed contractor shall be debarred from participating in the tender for executing the balance work. If the failed contractor is a JV or a Partnership Firm, then every member/Partner of such a firm shall be debarred from participating in the tender for the balance work in his/ her individual capacity or as a partner of any other JV/Partnership firm.</p> <p>(g) The Engineer shall not make a Claim under the Performance Guarantee except for amount to which the President of India is entitled under the contract (not withstanding and/or without prejudice to any other provisions in the contract agreement) in the event of:</p> <p>(i) Failure by the contractor to extend the validity of the Performance Guarantee as described herein above in which event the Engineer may claim the full amount of the Performance Guarantee.</p> <p>(ii) Failure by the contractor to pay President of India any amount due, either as agreed by the Contractor or determined under any of the Clauses/Conditions of the agreement, within 30 days of the service of notice to this effect by Engineer.</p> <p>(iii) The Contract being determined or rescinded under provision of the GCC clause 62.</p>
5.3	<p>Whenever the Railway /PSUs are awarded works contracts by RCIL/Railway, on single tender basis, they are exempted from the requirements of submitting performance guarantee.</p> <p>However, in the event of failure of the Railway PSU to successfully execute the contract as per terms and conditions laid down in the agreement, a penalty equivalent to 5% of the original value of contract would be levied.</p> <p>If Railway PSUs are awarded contract through competitive bidding (open tender, special limited</p>

	tender etc.) the normal rules regarding submission performance bank guarantee as applicable to other tenderer/s shall be applicable to these PSUs.
6.0	<u>CONDITIONS OF CONTRACT AND SPECIFICATIONS</u>
6.1	<p>Except where specifically stated otherwise in the tender documents the work is to be carried out in accordance with (i) Indian Railway Standard General Conditions of Contract, April 2022 amended fromtime to time & upto date.</p> <p>Note:- The above publications are available on www.indianrailway.gov.in</p>
6.2	<p>Order of Precedence of Documents: In a tender/contract, in case of any difference, contradiction, discrepancy, with regard to Conditions of tender/contract, Specifications, Drawings, Bill of quantities etc., forming part of the tender/contract, the following shall be the order of precedence:</p> <ol style="list-style-type: none"> i. Letter of Award ii. Schedule of Items, Rates & Quantities iii. Special Conditions of Contract iv. Technical Specifications as given in tender documents v. Drawings vi. Indian Railway Standard General Conditions of Contract updated with correction slips issued up to date of inviting tender or as otherwise specified in the tender documents. vii. *CPWD/Railways Specifications 2019 Vol I & II updated with correction slips issued up to date of inviting tender or as otherwise specified in the tender documents, if applicable in the contract. viii. *Indian Railway Unified Standard Specification (IRUSS-2019) updated with correction slips issued up to date of inviting tender or as otherwise specified in the tender documents, if applicable in the contract. ix. Indian Railway Unified Standard Specifications (Works and Material) 2010 updated with correction slips issued up to date of inviting tender or as otherwise specified in the tender documents, if applicable in the contract. x. IR Specifications/Guidelines updated with correction slips issued up to date of inviting tender or as otherwise specified in the tender documents. xi. Relevant B.I.S. Codes updated with correction slips issued up to date of inviting tender or as otherwise specified in the tender documents <p>*CPWD/Railways Specifications 2019 Vol I & II updated with correction slips and Indian Railway Unified Standard Specification (IRUSS-2019) updated with correction slips will be followed on issuance of order from this office.</p>
7.0	<u>STUDY OF DRAWINGS AND LOCAL CONDITIONS</u>
7.1	The drawings for the works can be seen in the office of the ED/RP. It should be noted by tenderer/s that these drawings are meant for general guidance only and RCIL/Railway may suitably modify them during the execution of the work according to the circumstances without making the RCIL liable for any claims on account of such changes.
7.2	The tenderer/s is/are advised to visit the site of work and investigate actual conditions regarding nature and conditions of soil, difficulties involved due to inadequate stacking space, due to built up area around the site, availability of materials water and labour probable sites for labour camps, stores, godowns, etc. They should also satisfy themselves as to the sources of supply and adequacy for their respective purpose of different materials referred in the specifications and indicated in the drawings. The extent of lead and lift involved in the execution of works and any difficulties involved in the execution of work should also be examined before formulating the rates for complete items of work described in the schedule.

7.3	<p><u>Fencing at work site</u> Contractor(s) while executing the work shall provide suitable fencing/barricading to protect/segregate the existing Railway line from any damage and un-toward incident, as per the directions or plan approved by Engineer-in-charge. The payment of barricading/fencing shall be paid under the relevant N.S. item if required. No work will be started till the fencing/barricading is provided and clearance in writing is issued by the Engineer-in-charge.</p>
7.4	<p><u>Safety Gear :</u> During execution of the work, contractors shall ensure that all safety precautions are taken by their men to protect themselves and site to prevent any untoward incident. In this regard contractor will ensure that adequate number of safety helmets, safety belts, safety jackets with reflective arm band, rope, ladders emergency light etc. are available at site before the work is actually started. The above list is only indicating and is not exhaustive and safety item will be arranged as per the requirement. RCIL reserve the right to stop the work in the absence of proper safety gear and no claim shall be entertained in this regard. Decision of the Engineer-in-charge will be final and binding upon the contractor. The cost of all the safety gear is deemed to have been included in the rates quoted and nothing extra is payable under this contract.</p>
8.0	<p><u>PERIOD OF COMPLETION :-</u></p>
8.1	<p>The entire work is required to be completed in all respects within 06 months from the date of issue of Acceptance letter. Time is the essence of contract. The contractor/s will be required to maintain speedy and required progress to the satisfactions of the Engineer to ensure that the work will be completed in all respects within the stipulated period failing which action may be taken by the RCIL Administration in terms of Clause 17 and/or Clause 62 of the Indian Railway Standard General Conditions of Contract, April, 2022 amended from time to time & up to date.</p>
8.2	<p>The contractor/s shall arrange to execute the different items of works in close consultation with and as per directions of the Engineer so that other works being executed in the same area either departmentally or through another agency such as steel erection, P. Way earthwork in formation, etc. are also progressed concurrently. It may be noted, however, that any delay in the execution of departmental works, for whatsoever reason shall not be accepted as an excuse for non-performance of the contract.</p>
8.3	<p>The contractor/s will be required to give GGM/Signal a monthly progress report of the work done during the month on 4th of the following month. He will also give to the Work Incharge/ GGM/Signal the programme of work to be done in coming month by 25th of the preceding month. The programme will be subject to alteration or modifications at the direction of the ED/RP, who may discuss such modifications or alterations with the contractor as considered necessary. Approval of any programme shall not in any way relieve the contractor from any of his obligations to complete the whole of the work by the prescribed time or extended time, if any.</p>
9.0	<p><u>RATES FOR PAYMENT</u></p>
9.1	<p>The rates given in the attached schedule of rates tendered by the contractor and as accepted by RCIL will form the basis of payment for such items under this contract.</p>
9.2	<p>No material price variation or wages escalation on any account whatsoever the Compensation for `Force Majeure' etc. shall be payable under this contract except price escalation clause payable as per price escalation clause, if any, provided separately in the tender documents.</p>
9.3	<p>The rates for any item of work not included in the (Schedule of Items, Rates and Quantities) and which the contractor may be called upon to do by RCIL Administration shall be fixed by the supplementary written agreement between the contractor and the RCIL/ before the particular item or items of work is/are executed. In the event of such agreement not being entered into and executed the RCIL may execute these works by making alternative arrangements. RCIL will not be responsible for any loss or damages on this account.</p>

9.3.1	The contractor shall work in close co-operation with the contractors, departmental staff working in the adjacent sections of Railway & local authorities.
9.4	It should be specifically noted by the tenderers that no separate loading, unloading and leading charges for materials (which are supplied by the RCIL) shall be paid for by RCIL and the rates quoted by the tenderer/s shall be inclusive of all these charges.
9.5	The item numbers, description, units and rates given in schedule of rates are as per Northern Railway Unified Standard Schedule of Rates, 2010 and any discrepancy during the execution of the work in the working rates, quantity and units etc. should be rectified by reference to the printed schedule of rates which be treated as authority and will be binding on the contractor.
9.6	Should there arise any items which may be necessary for the completion of work but which does not appear in the Schedule of Items, Rates and Quantities attached with tenders, its rate will be fixed by analysis of actual inputs of all types including labour and material or derived from the labour and material rates given in the Northern Railway Unified Standard Schedule of Rates, 2010. The rates for such non-scheduled items occurring during the course of construction shall be payable subject to the approval of the competent authority. No items or work requiring non-schedule rates will be carried out unless ordered to do so by the Engineer. The rates derived from the Northern Railway Unified Standard Schedule of Rates, 2010 will be subject to percentage above or below tendered by the contractor.
9.7	Payment for the work done will be made to the contractor only when the formal agreement has been executed between the parties.
9.8	The rates quoted by the contractor and accepted by RCIL as per Schedule of Items, Rates and Quantities shall form the basis of 'on account <u>payment</u> ' or the various items under this contract.
9.9	In the course of execution of various items of work under schedule of Items, Rates and Quantities running bills payment for partly completed works will be made to the contractor. The quantum of such work for payment shall be decided by the Engineer-in-charge whose decision shall be final and binding on the contractor.
9.10	No 'on account payment' by the RCIL shall protect the contractor/s against or prevent the RCIL from recovering from the contractor/s any over payment made to him/them.
9.11	Final payment of the balance amount due, exclusive of the security deposit required in terms of Clause-5 of these special conditions, will be made after the completion of the entire work and on the certification of the Engineer that work has been completed in all respects and found satisfactory. The security deposit will be refunded after the date of completion according to Clause 5.1 of these conditions.
9.12 (a)	Final SUPPLEMENTARY AGREEMENT After the work is completed or otherwise concluded by the parties with mutual consent, and taken over by the RCIL/Railway as per terms and conditions of the contract agreement, and there is unequivocal no claim on either side under the contract, other than as mentioned in item 4 of Annexure-B, the parties shall execute the final supplementary agreement as per Annexure-B.
9.12 (b)	<u>Standard Agreement (for EBR-IF Funded Contract only):- (Not Applicable).</u>
9.13	<u>Measures to be taken in construction and repairs on roads, embankments, etc.</u>
9.13.1	All borrow pits dug for and in connection with the construction and repairs of buildings, roads, embankments, etc. shall be deep and connected with each other in the formation of a drain directed towards the lowest level and properly sloped for discharge into a river, stream, channel or drain and no person shall create any isolated borrow pit which is likely to cause accumulation of water which may breed mosquitoes.

9.13.2	Non fulfillment of the provision in 9.13.1 above shall be a breach of the contract and contractor/s shall be liable to pay by way of agreed liquidated damages to the RCIL at the rates of Rs.100/- for each breach and in addition to that contractor further undertake to pay the amount incurred by the RCIL in getting the said job/s done at the risk and cost of the contractor. Besides this, the contractor will also be held responsible for any laws for contravening them.
10.0	<u>SETTING OUT WORKS</u>
10.1	The contractor is to set out the whole of the work in consultation with the engineer or an official to be deputed by the Engineer and during the progress of works to amend on the requisition of the Engineer any errors, which may arise there in and provide efficient and sufficient staff and labour thereon. The contractor shall also alter or amend any errors in the dimension lines on levels to the satisfaction of the Engineer or his authorized representative without claiming any compensation for the same.
10.2	The contractor shall provide, fix and be responsible for maintenance of all stocks, templates, profiles, land marks, points, burjies, monuments, center line pillars, reference pillars, etc. and shall take all necessary precautions to prevent their being removed altered or disturbed and will be responsible for the consequence of such removal, alterations or disturbance and for their efficient reinstatement.
10.3	The contractor shall protect and support, as may be required or as directed by the Engineer, all building, fences, walls, towers, drains, road paths, waterways, foreshores banks, bridges, Railway ground and overhead electric lighting, the telegraphs/ telephones and crossing water service Main pipes and cables and wires and altogether matters and things of whatever kind not otherwise herein specified other than those specified or directed to be removed or altered which may be interfered with or which likely to be affected disturbed or endanger by the execution completion of maintenance of the works and shall support provided under this clause to such cases as directed by the Engineer. No payment shall be made by the RCIL to the contractor for these works on account of delay for re-arrangement of road traffic or in the contractor having to carry out the short lengths and in such places as per conditions and circumstances may warrant. These will not form the basis of any claim and or dispute for compensation of any kind.
11.0	<u>DRAWINGS FOR WORKS:</u>
11.1	The RCIL/Railway Administration reserves the right to modify the plans and drawings as referred to in the special data and specifications as also the estimate and specifications without assigning any reasons as and when considered necessary by the RCIL. The percentage rates for the schedule items and items rates for the non-schedule items quoted by the contractor as may be accepted by the RCIL will, however, hold good irrespective of any changes, modifications, alterations, additions, omissions in the locations of structures and detailed drawings, specifications and/or the manner of executing the work
11.2	It should be specifically noted that some of the detailed drawings may not have been finalized by the RCIL/Railway and will, therefore, be supplied to the contractor as and when they are finalized on demand. No compensation whatsoever on this account shall be payable by the RCIL Administration.
11.3	No claim whatsoever will be entertained by the RCIL on account of any delay or hold up of the work/s arising out of delay in approval of drawings, changes, modifications, alterations, additions, omission and the site layout plans or details drawings and design and or late supply of such material as are required to be arranged by the RCIL or due to any other factor on RCIL/ Railway Accounts.
12.0	<u>SUPPLY OF MATERIALS BY THE RailTel (Not Applicable)</u>

12.1	<p>If at any time, material which the contractor/s should normally have to arrange himself/themselves, are supplied by the RCIL either at the contractor's request or in order to prevent any avoidable delay in the execution of work due to the contractor's inability to make adequate timely arrangements for supply thereof or for any other reason, recovery will be made from the contractor's bill either at the market rate prevailing at the time of supply or at the book rate whichever is greater, plus fixed departmental charges viz. Freight at 5% (8.33% for items of Iron and G.I. pipe steel) incidental charges at 2% and added on total cost supervision charges at 12.5%. No carriage or incidental charges will be borne by the RCIL. The contractor cannot, however, claim as a matter of right the issue of such material by the RCIL which he/they is required to arrange himself/themselves in accordance with the terms and conditions of this contract.</p>
12.1.1	<p>In case, cement and/or steel is issued to the contractor/s free of cost or on cost to be recovered for use on the work, the supply thereof shall be made in stages limited to the quantity/ quantities computed by the RCIL according to the prescribed specifications and approved drawings as per the agreement. The cement and/or steel issued in excess of the requirements as above shall be returned in perfectly good conditions by the contractor to the RCIL immediately after completion or determination of the contract. If the contractor/s fail/s to return the said stores, then the cost of cement and/or steel issued in excess of the requirement computed by the RCIL according to the specifications and approved drawing will be recovered from the contractor/s @ twice the prevailing procurement cost at the time of last issue viz. 2 X (purchase price + 5% freight only). This will be without prejudice to the right of the RCIL to take action against the contractor/s under the conditions of the contract for not doing/completing the work according to the prescribed specifications and approved drawings. If it is discovered that the quantity of cement and or steel used is less than the quantity ascertained as herein before provided, the cost of the cement and/or steel not so used shall be recovered from the contractor/s on the basis of the above stipulated formula.</p>
12.1.2	<p>The contractor shall be responsible for the safe transport custody and storage of all RCIL/ Railway materials issued to him and he will be liable to make good the loss due to any cause whatsoever, that may be suffered by the RCIL/ Railway on this account. Special precautions should be taken in respect of cement while transporting cement, steps should be taken to safeguard against cement becoming damp or wet due to moisture or rain. The contractor will also be responsible for storing cement in damp proof conditions at site of work at his own cost in accordance with the standard specifications. The Engineer shall decide whether the cement stored in the godown is fit for the work and his decision shall be final and binding on the contractor/s.</p>
12.2	<p>The contractor should supply a schedule showing the requirements of explosives/materials required to be supplied to him by the RCIL based on detailed plans. The materials will be arranged by the RCIL according to this schedule unless otherwise modified by the RCIL due to additions or alterations in the approved plans. No claim whatsoever will be entertained by the RCIL on account of late supply of such materials as are required to be arranged by the RCIL .</p>
12.3	<p><u>SUPPLY OF CEMENT AND STEEL BY THE RCIL (No supply of Cement and Steel will be made by RCIL)</u></p>
12.3.1	<p>Cement, Mild Steel/ H.Y.S.D./ Bars/RSJ/MS Plate, etc. to be supplied by the RCIL to the extent as would become a part of the work involved in the tender schedule will be supplied by the RCIL free of cost or on cost recovery basis as the case may be as per relevant clauses of special conditions relating to site data and specifications at construction store godown. The contractor will be required to lead the same to the site of work at his own cost subject to payment at the rate as quoted against relevant item of N.S. Items in the Schedule of Items, Rates & Quantities.</p>

12.3.2	Cement and steel required for temporary works timbering, shuttering, centering, scaffolding, etc. will have to be arranged entirely by the contractor at his own cost.	
12.3.3.	The empty cement bags for the supply of cement by the RCIL shall be property of the contractor and the cost of the same shall be recovered at the rate of Rupees Two per empty cement bag from the 'on account bill' of the contractor in case the cement is supplied in Jute bags. No recovery on account of empty cement bags shall be made from the contractor, in case the cement is supplied in H.D.P.E. bags. The RCIL however, reserves its right to take empty bags as are in good conditions and in that case no recovery will be made for bags so taken back. These rates will apply for bags deteriorated while in use and not found acceptable to the RCIL/Railway so taken back from the contractor.	
13.0	<u>SUPPLY OF MATERIALS BY THE CONTRACTOR/S</u>	
13.1	Materials used in the work by the contractor shall conform to the Northern Railway Standard Specifications as mentioned in Northern Railway CE's Circular No. 630 dtd.26.12.2016.	
13.2	It should be clearly understood that the tendered rates include wastage and wash away due to rains, storms, floods or any other cause whatsoever.	
13.3	No loading, unloading, lead, lift, stacking, octroi, sales tax, toll tax, royalty or any other charges will be paid for the materials, tools and plants and tools arranged and brought by the contractor to the site of work.	
13.4	Stage payment for supply of steel by the contractor (For Original Contract Value above Rs15 Crores) NOT APPLICABLE FOR THIS TENDER)	
	<p>(a) Stage payment limited to 75% of the rate of steel awarded in the contract (as a separate NS item/USSOR item for the purpose) shall be made to the contractor for steel physically brought by the contractor to the site (even before its actual use in the work) subject to following: -</p> <p>(i) The material shall be strictly in accordance with the contract specifications.</p> <p>(b) The material shall be delivered at site and properly stored under covered sheds at contractor's cost and protected against damage, deterioration, theft, fire etc. to the satisfaction of the engineer in charge. The contractor shall store the bulk material in the measurable stacks.</p> <p>(ii) The quantities of materials shall be brought to the site only in such installments that would facilitate smooth progress of work and consumed in reasonable time. The decision of Engineer-in-charge regarding quantity of steel to be brought to the site shall be final and binding to the contractor.</p> <p>(iii) Proper accountal in the material registers to be maintained in the prescribed format at the site for the receipt and use of the material on day-to-day basis.</p> <p>(iv) Submission of indemnity bond with validity up to the completion/extended period in the prescribed format at the contractor's cost, vesting the ownership of such material with the RCIL.</p>	

	<p>(c) Submission of insurance policy with a validity upto the completion/extended period at the contractor's cost, in favour of the RCIL against damage, deterioration, theft, fire etc.</p> <p>(d) The balance payment shall be released only after material is actually consumed in the work. The price variation claim for steel would continue to be governed as per extant PV clause and with reference to delivery at site.</p>	
14.0	<u>SERVICE ROADS</u>	
14.1	The contractor/s shall make his/their arrangements for service roads, paths etc for carrying his/their tools and plants, labour and materials, etc. and will also allow the RCIL/Railway use of such paths and service roads, etc for plying its own vehicles free of cost. The tenderer/s will be deemed to have included the cost of making any service roads, roads or paths, etc., that may be required by him/them for plying his/their vehicles for the carriage of his/their men and materials, tools, plants and machinery for successful completion of the work. Similarly, any other feeder road connecting any of the existing roads will be made by the contractor at his/their own cost including any compensation that may be required to be paid for the temporary occupation and or usage of Govt. and or private land and without in any way involving the RCIL in any dispute for damage and/or compensation.	
14.2	In case the RCIL/Railway has its own paths, service roads, the contractor/s will be allowed to use of such paths or service roads free of cost. He/They shall, however, in no way involve the RCIL in any claims or dispute of whatever kind due to the inaccessibility of such paths or service roads or due to their poor condition and or maintenance or their being to be blocked and/or closed.	
14.3	The rates quoted by the contractor as per Schedule of Items, Rates and Quantities shall form the basis of 'on <u>account payment</u> ' or the various items under this contract.	
14.4	In the course of execution of various items of work under schedule of Items, Rates and Quantities running bills payment for partly completed works will be made to the contractor. The quantum of such work for payment shall be decided by the Engineer-in-charge whose decision shall be final and binding on the contractor.	
14.5	No 'on account payment' by the RCIL shall protect the contractor/s against or prevent the RCIL from recovering from the contractor/s any over payment made to him/them.	
14.6	Final payment of the balance amount due, exclusive of the security deposit required in terms of Clause-5 of these special conditions, will be made after the completion of the entire work and on the certification of the Engineer that work has been completed in all respects and found satisfactory. The security deposit will be refunded after the date of completion according to Clause 5.1 of these conditions.	
15.0	<u>EMERGENCY WORK</u>	
15.1	In the event of any accident or failure occurring in or about the work of arising out for or in connection with the construction completion or maintenance of the work which in the opinion of the Engineer require immediate attention, the RCIL may be with its own workmen or other agency execute or partly execute the necessary work or carry out repairs if the Engineer considers that the	

		contractor is not in a position to do so in time and charge the cost thereof, as to be determined by the ED/RP to the contractor.	
15.2		In terms of clause 32 of Indian Railway Standard General Conditions of Contract, April, 2022 amended from time to time & upto date;, the material and plants brought by the contractor on the site or land occupied by the contractor in connection with the works and intended to be used for execution thereof shall immediately, they are brought upon the sites of this said land be deemed to be the property of the RCIL, vehicles, equipments, plant and machinery of the contractor can be drafted by the RCIL Administration at their discretion in case of accidents, natural calamities involving human lives, breaches, stoppage of train operations or any contingencies which require such requisitioning as essential. The decision in this regard of the Engineer-in-charge or his superiors i.e. DGM/Addl. GM/GM etc. shall be final and beyond the ambit of arbitration clause.	
15.3		In terms of clause 2.3.2 (A) (iv), tenderer is required to submit the list of equipment, machinery, construction tools and plants available /deployed at site. The successful tenderer on receipt of acceptance letter and conveying their consent shall submit name, addresses, telephone numbers, Fax number/E Mail address of the persons to be contacted for requisitioning the above items as detailed in forgoing clause 15.2 and notify from time to time if any change in the list of equipments/machinery or the addresses/ individuals to the Engineer-in-charge in writing. The name and address, telephone numbers and the contractor officials name shall also be displayed at the site of work.	
15.4		The manpower, consumable items and maintenance of the above tools and plants when requisitioned shall be the responsibility of the tenderer/contractor so that the equipments, machinery, tools and plants shall be available for effective utilization at the accident sites, natural calamities, breaches sites etc.	
15.5		<p>The hire charges per annum shall be calculated at the following rates on the purchase cost of the plant as under (Not Applicable)</p> <p>(a) Depreciation charges at the following rates</p> <p>a) Light plant 16% per annum</p> <p>b) Heavy plant 10% per annum</p> <p>c) Special plant 6% per annum</p> <p>(ii) In additional 10% on the total of (i) above to meet contingencies</p> <p>(iii) 10% contractor profit on total cost as detailed (i) to (ii)</p> <p>(iv) The hire charges per day shall be arrived at dividing the annual hire charges of total of (i) to (iii) above by 365 which shall be the assumed number of working days in year for this purpose. These hire charges will be payable from the date the plant is handed over to the RCIL to date on which it is returned to the contractor by RCIL .</p> <p>(v) The contractor man power charge shall be payable @ minimum wages as notified by the State Govt. /local bodies /labour Deptt. As the case may be for highly skilled, semi skilled personnel drafted for operating the plant and machinery.</p> <p>(vi) The payment for the fuel cost shall be paid on the basis of the actual expenditure incurred by the contractor for purchase + 10% contractor's profit thereof which will be the payments towards his miscellaneous expenses too.</p>	
16.0		<u>NIGHT WORK</u>	

16.1	If the Engineer is satisfied that the work is not likely to be completed in time except by resorting to night work, he may order without confirming any right on the contractor for claiming any extra payment for the same.	
17.0	<u>DISPOSAL OF SURPLUS EXCAVATED MATERIALS</u>	
17.1	The contractor shall at all time keep the site free from all surplus earth, surplus materials, and all rubbish which shall arise from the works and should dispose of the surplus excavated materials as ordered by the Engineer failing which it will be done at the cost of the contractor and cost will be deducted from his dues.	
17.2	The contractor shall within 15 days of completion of entire works remove all unused and surplus materials tools and plants staging and refuge or other materials produced by his operations and shall leave the site in a clear and tidy conditions.	
18.0	<u>SITE INSPECTION REGISTER</u>	
18.1	A site inspection register will be maintained by the Engineer or his representative in which the contractor will be bound to sign day to day entries made by the Engineer or his representative. The contractor is required to take note of the instructions given to him through the site inspection register and should comply with the same within a reasonable time. The contractor will also arrange to receive all the letters etc. issued to him at the site of works.	
18.2	The contractor shall, from time to time (before the surface of any portion or the site is interfered with or the work thereon begun) take such levels as the Engineer may direct in his presence or any person 63s aforesaid by him in writing. Such levels approved and checked by him or such 63s aforesaid persons shall be recorded in writing and signed by the contractor and shall form the basis of the measurements. Immediately before any portion of the work, below water level is started, the existing water levels are to be taken and recorded in a similar manner.	
19.0	The contractor shall have to make and maintain at his own cost suitable approach road and path, etc for proper inspection of the various works. He shall also provide all facilities as required by the Engineer such as Ladder and other appliances for satisfactory inspection of the works and places where materials for the work are stored or prepared.	
20.0	<u>OPENING UP OF WORK OR MATERIALS FOR INSPECTION OR TEST:</u>	
	Should the Engineer, or any representative consider it necessary for the purpose of enabling inspection of tests analysis to be made to verify or ascertain the quality of any part of the works or of any materials, the contractor shall as and when required by the Engineer or his representatives open up the work or materials for inspection or test or analysis, pull down or cut into any part of the work to make such openings, into under or through any part of the works as may be directed and shall provide all things facilities which in the opinion of the Engineer or his representative are necessary and essential for the purpose of inspection or test or analysis of the works or of any part thereof or the materials, or of workmanship and the contractor shall close up, cover, rebuild and made good the whole at his own cost, as and when directed by and to the satisfaction of Engineer provided that of the work in the opinion of the Engineer is found to his satisfaction and in accordance with the contract.	

		The excess expenditure in such examination, inspection or test shall, upon the certificate of the engineer, be borne by the RCIL.	
21.0		GENERAL	
21.1		<u>PROVISION OF LIGHT SIGNALS ETC (Not Applicable) .</u>	
		The contractor/s shall make such provision for lighting the works, materials and plant and provide all such marks and lights, signals and other appliances as may be necessary or as may be required by the Engineer or other responsible authorities during the execution completion and maintenance of the work and shall provide all labour, stores, etc. required for their efficient working and use at any time of day or night. He/They shall also provide all arrangement of every description of watching and maintenance required in connection with the foregoing and all other services for protection of any securing all dangerous places whether to the contractor's workmen or to other persons and or vehicular traffic until the work is certified by the engineer to have been completed and taken over in accordance with the contract.	
21.2		The contractor/s will provide upon the works to the satisfaction of the Engineer and at such, places as he may nominate, proper and sufficient life saving, fire fighting and first aid appliances which shall at all times be available for use.	
21.3		<u>LABOUR CAMPS</u>	
		Land for setting up a workshop by the contractor or for his labour camp or for any other purpose, shall have to be arranged by the contractor at his own cost and under his own arrangements. The contractor, however, will be permitted to make use of the Railway land to the extent that can be made available to him free of cost, by the RCIL in the vicinity of the site of works. The contractor/s shall at all times be responsible for any damage or trespass committed by his agent and workmen for carrying out the work.	
21.4		The RCIL Administration may recommend to the concerned authorities the issue of necessary transport permits for the work. The contractor shall, however, furnish full justification for the above facilities, to enable the RCIL Administration to address the State Government or other authorities in this connection. The contractor shall also maintain regular log book of receipts and issue of the materials to work, if so required by the Civil Authorities. No claim would, however, be entertained by the non-issue of any priority permits or owing to any interruption in supply.	
21.5		No claim for idle labour and or idle machinery etc. on any account will be entertained. Similarly, no claim shall be entertained for business loss or any such loss.	
22.0		DEFAULTS AND DELAYS	
		The Contractor shall execute the work with due diligence and expedition, keeping to the approved time schedule. Should he refuse or neglect to comply with any reasonable orders given to him in writing by the Purchaser's Engineers in connection with the work or contravene the provision of the Contract or the progress of work lags persistently behind the time schedule due to his neglect, the Purchaser shall be at liberty to give seven days notice in writing to the Contractor requiring him to make good the neglect or contravention complained of and should the Contractor fail to comply with the requisitions made in the notice within seven days from the receipt thereof, it shall be lawful for the purchaser to take the work wholly or in part	

	<p>I the Contractor's hands without any further reference and get the work or any part thereof, as the case may be, completed by other agencies at the expense of the Contractor without prejudice to any other right or remedy of the Purchaser. The contract shall be treated as terminated on the date a notice is issued by the purchaser to take the work wholly or in part out of the Contractor's hands. The purchaser shall be at liberty to encash the performance guarantee and forfeit the security deposit after the contract is terminated to reimburse the loss to purchaser.</p>	
22.1	LOSS SUSTAINED DUE TO DEFAULTS AND DELAYS	
	<p>In the event of any loss to the purchaser on account of execution and/or completion of the work or any part thereof by agencies other than the contractor, in terms of clause 33 the contractor shall be liable to reimburse the loss to purchaser without prejudice to the other rights and remedies of the purchaser and the reimbursement in full or in part, in case may be, shall be met at the option of the purchaser from out of all or any of the following sources viz :</p> <ul style="list-style-type: none"> i) Any amount due and payable to the contractor by the purchaser on any account whatsoever; ii) The Contractor's security deposit in the hands of the purchaser as far as available, and; iii) Any other assets whatsoever of contractor; iv) In the event of re-imbursement from out of sources (i) and/or (ii) above <p>mentioned, the purchaser shall have the right of appropriation suo moto.</p>	
22.2	PENALTY FOR DELAY IN COMPLETION	
	<p>Extension of Time with Liquidated Damages (LD) for delay due to Contractor With liquidated Damage (LD):</p> <p>The time for the execution of the work or part of the works specified in the contract documents shall be deemed to be the essence of the contract and the works must be completed not later than the date(s) as specified in the contract.</p> <p>If the contractor fails to execute and complete the construction of work of EI building within the time specified in the Agreement or within the period of extension granted under clause 22.3, for any reason whatsoever the contractor shall accept reduction in the total amount payable to him by the purchaser at a rate of 0.5% per week or part thereof (rounded off to the nearest whole number) of the total value of the contract for the delay occasioned beyond the appointed time by which the work should have been completed under the contract.</p>	
22.2.1	The total value of penalty on account of above shall be limited to maximum of 10% (Ten percent) of the total contract value.	
22.2.2	<p>Such reduction shall be accepted by the purchaser in full satisfaction of the contractor's liability arising from delay only. This penalty for delay in completion will be applicable separately for each stage of completion of work when two or more stages of completion are specified in the contract. The purchaser's engineer shall at his sole discretion specify a time limit within which the unfinished portion of the work shall be completed after serving on the contractor a notice of Purchaser's intention to recover the said penalty in Form 11. In the event of failure of the contractor, the purchaser shall be at liberty to take action in accordance with provisions in Clause 22.0 and 22.1.</p> <p>NOTE: For purpose of this clause the value of work shall be calculated on the basis of unit prices included in schedule of requirements.</p>	

22.3	ADHERENCE OF TIME SCHEDULE		
22.3.1	Timely completion of the work is the essence of the contract. Delay in execution will attract Penalty.		
22.3.2	If any delay 66s aforesaid in clause 35 shall have arisen from any cause which the Purchaser may agree as being a reasonable ground for extension of time- the purchaser's engineer or his representative may allow such additional time as he may in his absolute discretion consider to be Reasonably justified by the circumstances of the case. Such extensions shall be granted, on request from contractor, with or without liquidated damages in the Form No.V.		
22.4	Bonus for Early Completion of Work (Clause 17-C of GCC-2022) (Not Applicable for this Tender):		
23.0	<u>TAXES.</u>		
23.1	The contract shall be governed by the Taxes applicable at the place of actual execution of work.		
23.2	<p>Taxes on works contract, octroi, royalty, toll tax, local tax on materials as well as services and any other tax levied by Central Govt /State Govt. or local bodies shall be borne by the tenderer. No part of such taxes on contractor's labour/material or any other account will be paid by the RCIL. Therefore, the contractor must ascertain the various taxes levied by the concerned Govt or local bodies at the place of execution of work and take into account for the same while quoting the rates. This should be kept in view before tendering.</p> <p>Note:</p> <p>i) Works contracts shall be treated as supply of services as per Schedule –II GST Act.</p> <p>ii) GST Act and Rules issued from time to time by the Government/ concerned authorities shall be applicable.</p> <p>iii) The successful Contractor/ suppliers/ service providers/ parties immediately after the award of tender shall register their firms under GSTIN (GST Identification Number) and submit immediately after the award of contract, without which no payment shall be released to the Contractor. The Contractor shall be responsible for depositing applicable GST to the concerned authority.</p>		
23.3	<p>However, if rates of existing GST or Cess on GST for Works Contract is increased or any new tax/cess on Works contract is imposed by Statute after the date of opening of tender but within the original date of completion/date of completion extended under Clause 17 & 17A of GCC-2022 and the Contractor thereupon properly pays such taxes/cess, the contractor shall be reimbursed the amount so paid.</p> <p>Further, if rates of existing GST or cess on GST for Works Contract is decreased or any tax/cess on Works contract is decreased/removed by Statute after the date of opening of tender, the reduction in tax amount shall be recovered from Contractor's bills/Security Deposit or any other dues of contractor with the Government of India.</p>		

23.4	RCIL will deduct the taxes specified by the concerned Central Govt/State Govt/Local bodies if required to be deducted at source under the relevant laws as applicable on the date of making the payment. RCIL will issue a certificate regarding tax so deducted. It will be responsibility of the contractor to make further correspondence with concerned Govt or local bodies to ensure full deposition of the tax or for claiming a refund, if due, as is done in case of income tax.	
23.5	In case any tax is notified to be deducted at source from a specified date and certain payments have already been made in the period that lapsed between the date of applicability of tax and the actual date of implementation of the same, tax required to be deducted at source for this period will be recovered from the subsequent payment.	
23.6	<p>Implementation of, The Building and Other Construction Workers (RECS) Act, 1996 and The Building and Other Construction Workers Welfare Cess Act, 1996 in Railway Contracts:</p> <p>The tenderers, for carrying out any construction work, shall get themselves registered with the Registering Officer under Section-7 of the Building and Other Construction Workers Act, 1996 and rules made thereto by the concerned State Govt., and submit certificate of Registration issued from the Registering Officer of the concerned State Govt. (Labour Dept.). The Cess shall be deducted from contractor's bills as per provisions of the Act.</p>	
23.7	<p>Contractor is to abide by the provisions of various labour laws in terms of clause 54,55,55-Aand 55-B of Indian Railway Standard General Condition of Contract. In order to ensure the same, an application has been developed and hosted on website 'www.shramikkalyan.indianrailways.gov.in'. Contractor shall register his firm/company etc. and upload requisite details of labour and their payment in this portal. These details shall be available in public domain. The Registration/ updation of Portal shall be done as under:</p> <p>(a) Contractor shall apply for onetime registration of his company/firm etc. in the Shramikkalyan portal with requisite details subsequent to issue of Letter of Acceptance. Engineer shall approve the contractor's registration in the portal within 7 days of receipt of such request.</p> <p>(b) Contractor once approved by any Engineer, can create password with login ID (PAN No.) for subsequent use of portal for all Letter of Acceptances issued in his favour.</p> <p>(c) The contractor once registered on the portal, shall provide details of his Letter of Acceptances (LOA) / Contract Agreements on Shramikkalyan portal within 15 days of issue of any LOA for approval of concerned engineer. Engineer shall update (if required) and approve the details of LOA filled by contractor within 7 days of receipt of such request.</p> <p>(d) After approval of LOA by Engineer, contractor shall fill the salient details of contract labours engaged in the contract and ensure updating of each wage payment to them on Shramikkalyan portal on monthly basis.</p> <p>(e) It shall be mandatory upon the contractor to ensure correct and prompt uploading of all salient details of engaged contractual labour& payments made thereof after each wage period.</p> <p>(f) While processing payment of any 'On Account bill' or 'Final bill' or release of 'Advances' or 'Performance Guarantee / Security deposit', contractor shall submit a certificate to the Engineer or Engineer's</p>	

	representatives that “I have uploaded the correct details of contract labours engaged in connection with this contract and payments made to them during the wage period in Railway Shramikkalyan portal at www.shramikkalyan.indianrailways.gov.in’ till ___Month, ___Year.”									
24.0	All payments in respect of the contract during the currency of the contract shall be made through National Electronic Fund transfer (NEFT) or Real Time Gross Saving (RTGS). The successful tenderer on award of contract must submit RTGS/NEFT Mandate Form complete in all respects as detailed at Annexure-J of the tender document. However, if the facility of RTGS/NEFT is not available at a particular location, the payment shall be made by Cheque. In such case the successful tenderer on award of contract will have to furnish contractor’s Bank Account Number and Name of the Bank against which all payments in respect of the contract during the currency of contract shall be made.									
25.0	<p>Damage to the Railway Property:</p> <p>Contractor(s) executing the works adjacent to the existing Railway track for e.g. doubling, gauge conversion, yard remodeling etc. will take all care for avoiding any damage to the underground/OH services such as S&T cables, electric cables/wires, pipelines/sewer lines etc. They must ensure that the work is started after obtaining clearance in writing from the Engineer-in-charge regarding the route for signaling/Electrical cables/water supply/ sewer lines etc. However, if any damage occurs during execution, he will immediately report the same to the Engineer-in-charge and stop the work further till clearance for restarting the work is given by the Engineer-in-charge. It may be further noted that if it is proved that damage is occurred due to the negligence on the part of the contractor, the cost of the damage will be recovered from him/them. The decision of Engineer-in-charge will be final and binding upon the contractor(s)</p> <p>Penalty to be imposed for damages to cable shall be as under:</p> <table border="1"> <thead> <tr> <th>Cable damaged</th> <th>Penalty per location (Rs...)</th> </tr> </thead> <tbody> <tr> <td>Only Quad cable or signaling cable</td> <td>1.0 Lakh</td> </tr> <tr> <td>Only OFC</td> <td>1.25 Lakh</td> </tr> <tr> <td>Both OFC & Quad</td> <td>1.5 Lakh</td> </tr> </tbody> </table> <p>(As per CCE letter No. 247-Sig/OFC Cut/Rail-Tel/Pt. II dated 08-01-2020.)</p>	Cable damaged	Penalty per location (Rs...)	Only Quad cable or signaling cable	1.0 Lakh	Only OFC	1.25 Lakh	Both OFC & Quad	1.5 Lakh	
Cable damaged	Penalty per location (Rs...)									
Only Quad cable or signaling cable	1.0 Lakh									
Only OFC	1.25 Lakh									
Both OFC & Quad	1.5 Lakh									
26.0	Master copy of the tender document will be available in the office ED/RP, After award of work, an agreement will be drawn up. The agreement shall be prepared based on the master copy available in the office of RCIL and not based on the tender documents submitted by the tenderer. In case of any discrepancy between the tender documents and the master copy, later shall prevail and will be binding on the tenderers. No claim on this account will be entertained.									
27.0	DELETED									
28.0	<p>Maintenance Period:</p> <p>The contractor will have to maintain the work for a period of 12 (Twelve) months from the date of completion of work as certified by Engineer-in-charge of the work.</p>									
29.0	Price Variation Clause : (NOT APPLICABLE IN THIS TENDER)									

30.0	Mobilization Advance: (Not Applicable) [Applicable for advertised tender value exceeding Rs.25 crores] (Not Applicable)		
30.1	The tender / contractor may be granted a recoverable interest bearing mobilization advance up to 10% of the contract value. The rate of interest will be applicable as circulated by Railway Board & shall be effective on the date of approval of payment of Mobilisation Advance by the Competent Authority.		
30.2	The advance will be granted in two installments viz. 5% of the contract value on signing of the contract agreement and the balance 5% on mobilisation of site establishment, setting up of offices, bringing in equipment and actual commissioning of work. Each installment will be released on submission of an irrecoverable guarantee (Bank Guarantee, FDRs, KVPs/NSCs) of at least 110% of the value of the sanctioned amount. The Bank Guarantee shall be from a Nationalized Bank in India in a form acceptable to the RCIL. These two guarantees (Bank Guarantee, FDRs, KVPs/NSCs) shall be returned as and when the value of the advance plus interest is recovered from the running bill. However, second/subsequent installments of mobilization advance shall be granted only after obtaining a certificate from contractor along with documentary proof of successful. Satisfactory utilization of previous installment of mobilization advance.		
30.3	The recovery of advance and interest thereon will be made through the on account bills, pro rata, commencing when the value of the work executed under the contract reaches 15% of the contract value, and completed when the value of the work executed under the contract reaches 85% of the contract value, or the assessed value of the work whichever is less.		
30.4	Interest will be recovered on the advance outstanding for the period commencing from the date of payment of advance till date of particular on account bill (through which recovery of principle is effected) and adjusted fully against such on account bills along with pro rata principle recovery. The rate of interest will be applicable as circulated by Railway Board & shall be effective on the date of approval of payment of Mobilisation Advance by the Competent Authority. The interest rate on Mobilisation Advance as per clause-30 above shall also be applicable to other advance extended by RCIL to contractors as per extent rules and instructions. Note: The various Instruments as listed for Performance Guarantee (Clause 5.2) will also be acceptable for Mobilization Advance.		
30.5	The Railway Board ACS no 46 to para 1264 of IR code for Engineering Department (Third Print)1999 will be applicable for various advances as mentioned therein.		
36.2	<u>MATERIAL TO BE SUPPLIED BY CONTRACTOR</u> (This item is not applicable for this tender)		

36.2.1	<p>The materials to be supplied by the contractor as per schedules enclosed with the tender document will be procured from RDSO approved sources if the item appears in RDSO approved list. In case of items not appearing in RDSO approved list of material, the material shall be procured from reputed suppliers or their authorized representatives, shall be of best quality and shall conform to relevant specifications, design and drawings duly inspected by RCIL/RITES/RDSO/Rly/Consignee. The contractor may be required to produce test certificates from the manufacturers whenever called for by the Engineer in Charge.</p> <p>Before procuring the material to be supplied by contractor, the contractor shall submit the names and addresses of Suppliers from whom it is proposed to procure the materials required to be supplied in the tender and shall take approval of RCIL for the same.</p>
36.2.2	<p>All materials required for the execution of the contract other than those specifically shown as being supplied by the RCIL/ Railway in this document shall be arranged and supplied by the contractor as detailed in the scope so as to realize the end objectives. The material supplied and used by the contractor shall be best quality available.</p>
36.2.3	<p>The quantities of equipment and material to be supplied by contractor are indicated in schedule of work. The supply of equipment and material shall also include required installation and other materials and documents etc. which may not be specifically mentioned herein, but which are usually necessary for completing the work in all respects. The materials supplied and used by the contractor shall be of best quality available. Quantities of equipment and material to be supplied by contractor are indicated in the schedule of works. These material/equipment's are to be supplied at the stores as specified in Vol.-II.</p>
37.0	<u>Deleted</u>
39.0	a) Deleted
40.0	<p>b) EXECUTION OF WORK</p> <p>c) All the work shall be executed in strict conformity to the provisions of the contract document and according to detailed drawings, specifications and instructions as may be approved from time to time by RCIL/ Railway based on detailed design and engineering carried out by contractor in line with requirements as per contract document. The contractor shall be responsible for ensuring that the work throughout are executed in the most substantial, proper and workmanlike manner with the quality of material and workmanship in strict accordance with the specifications and as per sound industrial practices and to the entire satisfaction of the RCIL/ Railway. In case of any doubts regarding any particulars of construction and any ambiguities in the plans, the decision of the purchaser's engineer shall be final and binding on the contractor.</p>
41.0	<u>SUPPLY OF TECHNICAL LITERATURES, DOCUMENTATION, DRAWINGS & COMPLETION PLANS ETC:(Not Applicable)</u>
46.0	(All the material supplied as per Technical Specifications will be inspected by RailTel representative/RITES).
53.0	<p>SPECIFICATION, DRAWING, REQUISITES AND REQUIREMENT:</p> <p>a) Specifications, drawings, requisites and requirements referred to in the body of this specification form an essential part thereof, the sources from which the drawings & specifications referred to in this Tender can be obtained from following sources:</p> <p>b) The installation shall comply with the requirements of the Signal Engineering Manual and General and Subsidiary Rules as applicable; it shall also conform to the Schedule of Dimensions and the Rules for Opening of Railway. These books are available with Hd. Qrs. Office, Baroda House, as well as the concerned field unit executing the work and can be given on loan if required for reference. Besides these, installation shall comply with requirements of Engineering Code, P-way Works and Way manual wherever applicable.</p>

	c) If, in the opinion of the tenderer, he is in a position to offer additional facilities and safeguards that have not been covered by these specifications, full and complete details of the facilities and the safeguards with their costs shown separately, must be furnished with the tender.
54.0	d) Deleted
55.0	Deleted
56.0	<p>PAYMENTS:</p> <p>Payment Conditions common to all buildings: Payment shall be made on plinth area basis as per actual measurements. The plinth area rates include all superstructure works specified in the foregoing paras but not limited to the same required to make the building functional. Foundation works upto plinth, general electrical works, External water supply, sanitary (excluding septic tank), drainage works required beyond 15m of the outer wall of the building are not included in the rates and shall be paid separately under relevant items. Similarly, any boundary wall/compound wall, footpath, road required to be constructed are not included in the rates and shall be paid separately under relevant items. Payment shall be made in stages depending upon the progress as below:-</p> <p>(i) After casting of roof slab and construction of the masonry walls : 45%</p> <p>(ii) After completion of plastering (inside and outside) : 15%</p> <p>(iii) After completion in all respects : 30%</p> <p>(iv) After handing over of the building : 10%</p> <p>Note:</p> <p>a) Measurements of plinth area for the purpose of payment shall be determined on the following principles.</p> <ol style="list-style-type: none"> i. The plinth area shall be measured separately for every floor and the basement, if any. ii. Internal sanitary shafts shall not be included in the plinth area. iii. The area of the stair case and lift shall be included but area of the mumti at the terrace level shall not be included in the plinth area. If a barsati is provided jointly with mumti then area of barsati excluding mumti at the terrace level shall be included in the plinth area.
57.0	Deleted
58.0	<p>LONG TERM AVAILABILITY OF SPARES AND SYSTEM SUPPORT</p> <p>i) The tenderer shall undertake to supply on payment all maintenance spares and tools required for the equipment during its lifetime. He shall also undertake to supply additional equipment required for replacement for expansion of the network that may become necessary due to additional traffic requirements. The price variation formula adopted in pricing such maintenance spare and additional supply that may be ordered in future shall be decided by mutual discussions.</p> <p>e) The manufacturer shall guarantee that spares part for the system shall be available for a minimum of eight years after acceptance of the system and thereafter at least 2 years notice shall be given to the RCIL before any equipment or components are discontinued or phased out from the manufacturing plans. This will enable the RCIL to assess the lifetime requirement of spares needed and order in sufficient quality prior to stoppage of the manufacture.</p>

	<p>f) That the successful tenderer shall further guarantee that if he goes out of production of spare parts, he shall supply the specifications of materials at no cost to the purchaser, if and when required in connection with the equipment to enable the purchaser to fabricate or procure from other sources.</p> <p>g) The supplier shall recommend and provide, prior to the system acceptance, calibration procedures. The recommendation shall include a list of the various calibration instruments, recalibration periods and extent of preventive maintenance for each test instrument.</p>
59.0	<p>h) MAINTENANCE OF INSTALLED GEARS</p> <p>a) MAINTENANCE OF WORKS: The maintenance period shall be of 12 months!</p> <p>The contractor shall at all times during the progress and continuance of the works and also for the period of maintenance specified in the tender form and after the date of passing of the certificate of completion by the RCIL representative or any other earlier date subsequent to the completion of the works that may be fixed by RCIL representative be responsible for and effectively maintain and uphold in good, substantial, sound and perfect condition all and every part of the works and shall make good from time to time and at all times, as often as the RCIL representative shall require, any damage or defect that may during the above period arise in or be discovered or be in any way connected with the works, provided that such damage or defect is not directly caused by errors in the contract documents, act of providence or instruction or civil riot, and the contractor shall be liable for and shall pay and make good to the RCIL or other persons legally entitled there to whenever required by the RCIL representative so to do, all losses, damages, costs and expenses they or any of them may incur or be put or be liable to, by reason or in consequence of the operations of the contractor or his failure in any respect.</p> <p>b) PLACING IN SERVICE & MAINTENANCE SUPERVISION</p> <p>i) After the equipment has been commissioned & placed in service and Provisional Acceptance certificate issued by Purchaser's Engineer, the contractor shall be responsible for proper maintenance supervision of the equipment for a period of 12 months from the date of commissioning. For this purpose he shall prepare a maintenance plan and make available the services of qualified maintenance engineer stationed at the location approved by Purchaser's Engineer who will guide and supervise the work of RCIL maintenance staff. The maintenance engineer of the tenderer will visit all the stations at least once in a month and attend to any fault on the systems.</p> <p>ii) During this period of maintenance supervision if any lacuna is noticed in the functioning as a result of any defect in design or manufacture, the same will be rectified by the contractor free of cost. During such rectification if any faulty equipment/modules need replacement or repair, they shall be provided by the contractor from the set of equipment or modules that the contractor should bring to the site of installation in addition to all the materials to be supplied against this contract. Use of spare modules covered under the Schedule of material of this tender shall not be permitted to be used during installation, commissioning and maintenance supervision period without personal approval of purchaser representative. Spares, so issued under unusual circumstances, should be replaced by the firm within seven days of the issue of spares.</p>
60.0	<p>PROVISIONAL ACCEPTANCE</p> <p>i) Immediately after the completion of the work at each station or after completion of work. in a block section herein after referred as sub-section, the contractor shall certify and advise the purchaser in writing that the installation is (i) complete, (ii) ready for satisfactory service and (iii) ready to be handed over. He will also place at the disposal of the purchaser the required staff for inspection, testing and putting it into operation.</p> <p>ii) The tests specified in Section - III Technical specification will be conducted jointly by the purchaser and contractor as soon as possible after receipt of advice of completion of one sub-section by the purchaser from the contractor. The test schedule shall be furnished by</p>

	<p>the tenderer, which will be modified by mutual discussion between the contractor and RCIL before finalization. Any component, modules, sub-assemblies or equipment failing during the commissioning test shall be replaced/repaired free of cost by the tenderer. (Not Applicable)</p> <p>iii) Purchaser's Engineer shall issue a Provisional Acceptance certificate for successful commissioning of whole system covering all materials and services included in the Schedule of works, after the acceptance test as per the approved test procedure have been completed and the performance has been found to meet the specifications. RCIL decision in this respect shall be final. The Provisional acceptance certificate shall be signed by both the parties.</p> <p>iv) The Purchaser's Engineer may issue such a certificate with respect to any part of the works before the completion of the whole of the works or with respect to any substantial part of the works which has been both completed to the satisfaction of the Purchaser's Engineer and occupied or used by the RCIL and when any such certificate is given in respect of a part of the works, such part shall be considered as completed and the period of Maintenance of such part shall commence from the date of such certificate. For outdoor cable laying works the provisional acceptance certificate may be issued after the jointing/termination is completed and block circuits are transferred on quad cable. (Not Applicable)</p> <p>v) Should the result/s of inspection and test be not satisfactory, an extension of one month will be granted to the contractor to make good the defects and deficiencies pointed out by the purchaser. Fresh inspection and test will then be carried out after the contractor has attended to the defects and deficiencies. If these tests are also not satisfactory the purchaser may proceed at the contractor's expense by all means deemed expedient to have the installation made satisfactory until they comply with the specifications, and approved drawings and designs.</p> <p>vi) In such a case or in the case of delay in completing the work under this contract within the time limit the purchaser reserves the right, if he deems it possible to use in a reasonable manner any part of the installation even if some installations are not completely erected. The purchaser will give to the contractor for this purpose 7 days previous notice. The contractor shall then take at his own expense all necessary steps to complete the work in accordance with the provisions of the contract. In case it becomes impossible to proceed with the above mentioned taking over tests or reasons other than for which the contractor is responsible, the Provisional Acceptance Certificate shall be issued at or within a mutually agreed reasonable period not exceeding six months after completion of installation.</p> <p>vii) The issue of provisional acceptance will not be withheld for rectification or minor defects as distinct from rejected equipment, which may not be essential for commissioning and operation of the installation. In such cases, only the value of the materials and cost of the rectification of the minor defects shall be withheld from the payments on provisional acceptance until rectification is completed.</p>
61.0	<p><u>FINAL ACCEPTANCE</u></p> <p>i) The final acceptance of the entire equipment installed in the section shall take effect from the date of expiry of the period of maintenance supervision as defined in para- 56.0 or the expiry of the last of the respective period of Maintenance Supervision of various sections for which Provisional Acceptance Certificates are issued or brought into full fledged operation, provided that the contractor has complied fully with his obligations under para- 56.0 in respect of each section under the contract.</p> <p>ii) If on the other hand the contractor has not so complied with his obligation under para 56.0 in respect of any section, the purchaser may either extend the period of maintenance supervision in respect of that section until the necessary works are carried out by the contractor or carry out those works suo-moto on behalf of the contractor at the contractor's expenses. After expiry of the period of maintenance supervision for each section, a certificate of Final Acceptance for the section shall be issued by the purchaser and the last of such certificate will be called the Last and Final Acceptance Certificate. The contract</p>

	<p>shall not be considered as completed until the issue of Final Acceptance Certificate by the purchaser.</p> <p>iii) The purchaser shall not be liable to the contractor for any dispute arising out of or in connection with the contract or execution of the work unless the contractor have made a claim in writing in respect thereof before the issue of Final Acceptance Certificate under this clause. The contractor shall be debarred from disputing the correctness of the items caused by the no claim certificate or demanding a reference to Arbitration in respect thereof.</p> <p>iv) Notwithstanding the issue of Final Acceptance Certificate, the contractor and the purchaser (subject to Sub Clause as above) shall remain liable for fulfillment of any obligation incurred under the provision of the contract prior to the issue of Final Acceptance Certificate which remains unperformed at the time such certificate is issued and for determining the nature and extent of such obligation, the contract shall be deemed to remain in force between the parties hereto.</p>
62.0	<p><u>WARRANTY:</u></p> <p>The contractor shall warranty that all materials & equipment to be supplied and installed as per this tender shall be free from defects and faults in design, material, workmanship and manufacture and shall be of the highest grade and consistent with the established and generally accepted standard for materials of the type ordered and in full conformity with the contract specifications.</p> <p>This warranty shall start from the date of issue of "Provisional Acceptance Certificate" which will be considered as date of commissioning of complete system for the purpose of Warranty and shall expire 1 year (12 months). The Contractor shall be responsible for the proper functioning of the system during the period of warranty.</p> <p>During the period of Warranty, the Contractor shall remain responsible to arrange replacement and for setting right at his own cost any equipment supplied by him, which is of defective manufacture or defective design or defective material/component and becomes unworkable due to any cause whatsoever. The decision of RCIL to attend to any damage or defect in work shall be final and binding on the Contractor.</p> <p>If it becomes necessary for the contractor to replace or renew any defective portions of the system under this clause, the contractor shall make the system functional by providing suitable replacements and restore back the original card / equipment after repairs to the same. The card / equipment so repaired should bear warranty equal to the end of original warranty period or minimum Six months from the date of repair, whichever is later. If any defect is not remedied within reasonable time, the RCIL may proceed to do the work at contractor's risk and expense, but without prejudice to any other rights, which the RCIL may have against the contractor in respect of such defects. (Not Applicable)</p> <p>All inspections, replacements or renewals carried out by the Contractor during the warranty period shall be subjected to the same conditions of the contract.</p> <p>All replacement and repairs and design change that the RCIL shall call upon the contractor to deliver or perform under this warranty shall be delivered and performed by the contractor within one month, promptly and satisfactorily.</p> <p>The decision of the RCIL in regard to contractor's liability and the amount, if any, payable under this warranty shall be final and conclusive.</p>

	Due to analysis of failures, if any design deficiency is pointed out by the RCIL/Railway, the contractor shall rectify it at his own cost.
63	Deleted
64	TRAINING (Not Applicable)
65	<ul style="list-style-type: none"> • ARBITRATION: As per para 64 of GCC attached. • SETTLEMENT OF DISPUTES: As per para 64 of GCC attached. • TERMINATION OF CONTRACT: As per para 62 of GCC attached.

66 Labour Laws The Contractor shall comply with all the relevant labour Laws including applicable labour cess, to the Contractor's Personnel, including Laws relating to their employment, health, safety, welfare, immigration, and emigration, and shall allow them all their legal rights. The contractor and his sub-contractors shall be responsible to ensure at his own cost, compliance to all laws, bye-laws, rules and regulations for the time being in force pertaining to the employment of local or imported labour and shall take all necessary precautions to ensure and preserve the health and safety of all staff employed directly or through sub-contractors or petty contractors on the works, which shall include all the acts listed in Appendix – 1 but not limited to the same.

The Contractor shall require his employees to obey all applicable Laws, including those concerning safety at work.

During continuance of the Contract, the Contractor and his Sub-Contractors shall abide at all times by all existing labour enactments and rules made there under, regulations, notifications and bye laws of the State or Central government or local authority and any other labour laws (including applicable labour cess), regulations, bye laws that may be passed or notification that may be issued under any labour law in future either by the State or the Central Government or the local authority. Salient features of some of the major labour laws that are applicable to construction industry are given in Appendix 1 to these Conditions of Contract.

67 Insurance

67.1 General Requirements for Insurances In this Clause, "insuring Party" means, for each type of insurance, the Party responsible for effecting and maintaining the insurance specified in the relevant Sub-Clause.

Wherever the Contractor is the insuring Party, each insurance shall be effected with insurers and in terms approved by the Employer. These terms shall be consistent with any terms agreed by both Parties before the date of the Letter of Acceptance. This agreement of terms shall take precedence over the provisions of this Clause.

Wherever the Employer is the insuring Party, each insurance shall be effected with insurers and in terms consistent with the details annexed to the Special Conditions of Contract.

If a policy is required to indemnify joint insured, the cover shall apply separately to each insured as though a separate policy had been issued for each of the joint

insured. If a policy indemnifies additional joint insured, namely in addition to the insured specified in this Clause, (i) the Contractor shall act under the policy on behalf of these additional joint insured except that the Employer shall act for Employer's Personnel, (ii) additional joint insured shall not be entitled to receive payments directly from the insurer or to have any other direct dealings with the insurer, and (iii) the insuring Party shall require all additional joint insured to comply with the conditions stipulated in the policy.

Each policy insuring against loss or damage shall provide for payments to be made in the currencies required to rectify the loss or damage. Payments received from insurers shall be used for the rectification of the loss or damage.

The relevant insuring Party shall, within the respective periods stated in the Contract Data (calculated from the Commencement Date), submit to the other Party:

- (a) evidence that the insurances described in this Clause have been effected, and
- (b) copies of the policies for the insurances described in Sub-Clause 18.2 [Insurance for Works and Contractor's Equipment] and Sub-Clause 18.3 [Insurance against Injury to Persons and Damage to Property].

When each premium is paid, the insuring Party shall submit evidence of payment to the other Party. Whenever evidence or policies are submitted, the insuring Party shall also give notice to the Engineer.

Each Party shall comply with the conditions stipulated in each of the insurance policies. The insuring Party shall keep the insurers informed of any relevant changes to the execution of the Works and ensure that insurance is maintained in accordance with this Clause.

Neither Party shall make any material alteration to the terms of any insurance without the prior approval of the other Party. If an insurer makes (or attempts to make) any alteration, the Party first notified by the insurer shall promptly give notice to the other Party.

If the insuring Party fails to effect and keep in force any of the insurances it is required to effect and maintain under the Contract, or fails to provide satisfactory evidence and copies of policies in accordance with this Sub-Clause, the other Party may (at its option and without prejudice to any other right or remedy) effect insurance for the relevant coverage and pay the premiums due. The insuring Party shall pay the amount of these premiums to the other Party, and the Contract Price shall be adjusted accordingly.

Nothing in this Clause limits the obligations, liabilities or responsibilities of the Contractor or the Employer, under the other terms of the Contract or otherwise. Any amounts not insured or not recovered from the insurers shall be borne by the Contractor and/or the Employer in accordance with these obligations, liabilities or responsibilities. However, if the insuring Party fails to effect and keep in force an insurance which is available and which it is required to effect and maintain under the Contract, and the other Party neither approves the omission nor effects insurance for the coverage relevant to this default, any moneys which should have been recoverable under this insurance shall be paid by the insuring Party.

Payments by one Party to the other Party shall be subject to Sub-Clause 2.5 [Employer's Claims] or Sub-Clause 20.1 [Contractor's Claims], as applicable.

The Contractor shall be entitled to place all insurance relating to the Contract (including, but not limited to the insurance referred to Clause 18) with insurers from any eligible source country.

67.2 Insurance for Works and Contractor's Equipment

The Contractor shall insure the Works, Plant, Materials, including those issued by the Employer and Contractor's Documents for not less than the full reinstatement cost including the costs of demolition, removal of debris and professional fees and profit, subject to a maximum value indicated in Contract Data.. This insurance shall be effective from the date by which the evidence is to be submitted under sub-paragraph (a) of Sub-Clause 18.1 [General Requirements for Insurances], until the date of issue of the Taking-Over Certificate for the Works.

The insuring Party shall maintain this insurance to provide cover until the date of issue of the Performance Certificate, for loss or damage for which the Contractor is liable arising from a cause occurring prior to the issue of the Taking-Over Certificate, and for loss or damage caused by the Contractor in the course of any other operations (including those under Clause 11 [Defects Liability]).

The insuring Party shall insure the Contractor's Equipment for not less than the full replacement value, including delivery to Site. For each item of Contractor's Equipment, the insurance shall be effective while it is being transported to the Site and until it is no longer required as Contractor's Equipment.

Unless otherwise stated in the Special Conditions of Contract, insurances under this Sub-Clause:

- (a) shall be effected and maintained by the Contractor as insuring Party,
- (b) shall be in the joint names of the Parties, who shall be jointly entitled to receive payments from the insurers, payments being held or allocated between the Parties for the sole purpose of rectifying the loss or damage,
- (c) shall cover all loss and damage from any cause not listed in Sub-Clause 17.3 [Employer's Risks],
- (d) shall also cover loss or damage to a part of the Works which is attributable to the use or occupation by the Employer of another part of the Works, and loss or damage from the risks listed in sub-paragraphs (c), (g) and (h) of Sub-Clause 17.3 [Employer's Risks], excluding (in each case) risks which are not insurable at commercially reasonable terms, with deductibles per occurrence of not more than the amount stated in the Contract Data (if an amount is not so stated, this sub-paragraph (d) shall not apply), and



- (e) may however exclude loss of, damage to, and reinstatement of:
 - i) part of the Works which is in a defective condition due to a defect in its design, materials or workmanship (but cover shall include any other parts which are lost or damaged as a direct result of this defective condition and not as described in sub-paragraph (ii) below),
 - ii) a part of the Works which is lost or damaged in order to reinstate any other part of the Works if this other part is in a defective condition due to a defect in its design, materials or workmanship,
 - iii) a part of the Works which has been taken over by the Employer, except to the extent that the Contractor is liable for the loss or damage, and
 - iv) Goods while they are not in the Country, subject to Sub-Clause 14.5 [Plant and Materials intended for the Works].

If, more than one year after the Base Date, the cover described in sub-paragraph (d) above ceases to be available at commercially reasonable terms, the Contractor shall (as insuring Party) give notice to the Employer, with supporting particulars. The Employer shall then (i) be entitled subject to Sub-Clause 2.5 [Employer's Claims] to payment of an amount equivalent to such commercially reasonable terms as the Contractor should have expected to have paid for such cover, and (ii) be deemed, unless he obtains the cover at commercially reasonable terms, to have approved the omission under Sub-Clause 18.1 [General Requirements for Insurances].

67.3 Insurance against Injury to Persons and Damage to Property

The insuring Party shall insure against each Party's liability for any loss, damage, death or bodily injury which may occur to any physical property (except things insured under Sub-Clause 18.2 [Insurance for Works and Contractor's Equipment]) or to any person (except persons insured under Sub-Clause 18.4 [Insurance for Contractor's Personnel]), which may arise out of the Contractor's performance of the Contract and occurring before the issue of the Performance Certificate.

This insurance shall be for a limit per occurrence of not less than the amount stated in the Contract Data, with no limit on the number of occurrences. If an amount is not stated in the Contract Data, this Sub-Clause shall not apply.

Unless otherwise stated in the Special Conditions of Contract, the insurances specified in this Sub-Clause:

- (a) shall be affected and maintained by the Contractor as insuring Party,
- (b) shall be in the joint names of the Parties,
- (c) shall be extended to cover liability for all loss and damage to the Employer's property including Railways Property (except things insured under Sub-Clause 18.2) arising out of the Contractor's performance of the Contract, and
- (d) may however exclude liability to the extent that it arises from:
 - (i) the Employer's right to have the Permanent Works executed on, over, under, in or through any land, and to occupy this land for the Permanent Works,
 - (ii) damage which is an unavoidable result of the Contractor's obligations to execute the Works and remedy any defects, and

- (iii) a cause listed in Sub-Clause 17.3 [Employer's Risks], except to the extent that cover is available at commercially reasonable terms.

67.4 Insurance for Contractor's Personnel

The Contractor shall affect and maintain insurance against liability for claims, damages, losses and expenses (including legal fees and expenses) arising from injury, sickness, disease or death of any person employed by the Contractor or any other of the Contractor's Personnel.

The Employer and the Engineer shall also be indemnified under the policy of insurance, except that this insurance may exclude losses and claims to the extent that they arise from any act or neglect of the Employer or of the Employer's Personnel.

The insurance shall be maintained in full force and effect during the whole time that these personnel are assisting in the execution of the Works. For a Subcontractor's employees, the insurance may be affected by the Subcontractor, but the Contractor shall be responsible for compliance with this Clause.

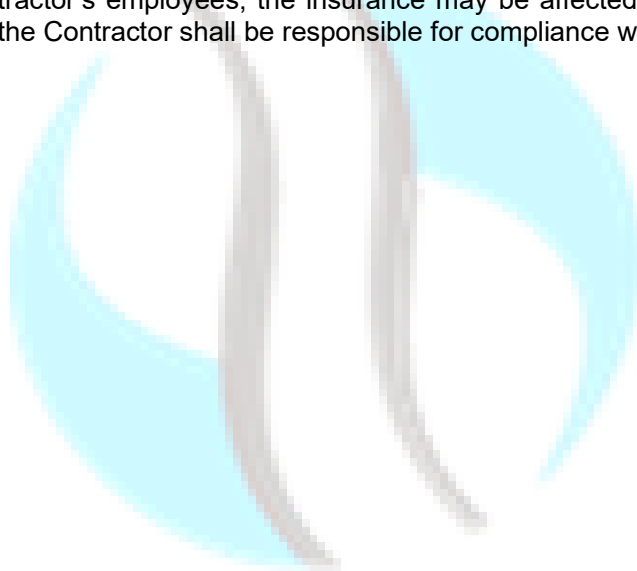

रेलटेल
RAILTEL

LIST OF ANNEXURES UNDER VOL. I OF TENDER DOCUMENT

ANNEXURE	ANNEXURE DETAILS
A	Performance Bank Guarantee
B	Final Supplementary Agreement.
C	Declaration for site visit.
D	Details regarding constitution of firm.
E	Details of Plant & Machinery
F	List of Engineers/Personel.
G	Statement of work executed/completed.
H	Statement of works being executed/in hand.
I	Detail of contractual payment received in last three financial year and current financial year as per balance sheets
J	Real Time Gross Saving (RTGS)/National Electronic Fund Transfer(NEFT) Model Mandate Form.
K	Guidelines for participation of Joint Venture (JV) firms.
K1	Format for Joint Venture Memorandum of Understanding/ Agreement.
K2	Guidelines for submitting tenders by Partnership Firms and their Eligibility Criteria.
K-3	Declaration by an existing Partnership Firm
K-4	Declaration by newly formed Partnership Firm
L	Completion Certificate.
M	Format for affidavit to be submitted by the tenderer.
N	Break up of Maximum value of Contractual payment received in any one year during the last three years and current financial year as per Balance Sheets
O-1	Affidavit by Sole Proprietorship Firm.
O-2	Power -of-Attorney for signing of bid on behalf of partnership firm.
O-3	Power -of-Attorney on behalf of Joint Venture.
O-4	Consent of partners of Partnership firm for signing Joint Venture.
O-5	Power -of-Attorney for signing Joint Venture agreement on behalf of partnership firm.
O-6	Affidavit by Sole Proprietorship Firm when Participating in Joint Venture.
O-7	Board's Resolution of company for entering into Joint Venture (To be printed on Company's letter head).
O-8	Power -of-Attorney by a company (incorporated under companies Act) for entering into Joint Venture agreement.
O-9	Power -of-Attorney for signing of bid (when Tenderer is company incorporated under companies Act)
O-10	Board's Resolution of company incorporated under companies Act for submitting Tender by company (To be printed on company's letter head)
O-11	Power -of-Attorney for signing of bid (when Tenderer is LLP Firm incorporated under LLP Act)

O-12	Partner's Resolution of LLP Firm incorporated under LLP Act for submitting Tender by LLP firm
O-13	Partner's Resolution of LLP Firm for entering into Joint Venture
O-14	Power -of-Attorney by a LLP Firm (incorporated under LLP Act) for entering into Joint Venture agreement.
O-15	Affidavit by HUF
P-1	Request letter from Executive branch to Accounts Office for opening of LC
P-2	Document of Authorization.
Q	Declaration regarding retired railway staff/officer
R	Standard Novation Agreement
S	Instructions for bidders from a country which shares a land border with India.
T/T1	Bid Security Declaration: Deleted (Not applicable)
U	Integrity pact
V	EXTENSION OF PERIOD OF COMPLETION OF WORK
AA	System Performance Guarantee
AB	Statement of Deviation
AC	Joint Inspection of Cable trench & protective works
AD	Standard Indemnity bond for On Account Payment
AE	Guarantee Bond
AF	Acknowledgment for receiving materials from Railway/RCIL



रेलटेल
RAILTEL

Proforma for Performance Bank Guarantee

PERFORMANCE BANK GURANTEEE

(On Stamp Paper of Rs. One Hundred)

(To be used by approved Scheduled Banks)

In consideration of the RailTel Corporation of India Limited : 6th floor, 3rd Block Delhi Technology Park Shastri Park, Delhi-110053

1. (Herein after called RailTel) having agreed to exempt (Hereinafter called "the said Contractor(s)") from the demand, under the terms and conditions of an Agreement No. dated made between and for (hereinafter called " the said Agreement") of security deposit for the due fulfillment by the said Contractor (s) of the terms and conditions contained in the said Agreement, or production of a Bank Guarantee for Rs. (Rs. only). We,(indicate the name of the Bank) hereinafter referred to as " the Bank") at the request of Contractor(s) do hereby undertake to pay the RailTel an amount not exceeding Rs. Against any loss or damage caused to or suffered or would be caused to or suffered by the RailTel by reason of any breach by the said Contractor(s) of any of the terms or conditions contained in the said Agreement.

2. We, Bank and our local branch at New Delhi (indicate detail address of local New Delhi Branch with code no.)do hereby undertake to pay the amounts due and payable under this Guarantee without any demur, merely on demand from the RailTel stating that the amount is claimed is due by way of loss or damage caused to or would be caused to or suffered by the RailTel by reason of breach by the said Contractor(s) of any of terms or conditions contained in the said Agreement or by reason of the Contractor(s) failure to perform the said Agreement. Any such demand made on the Bank shall be conclusive as regards the amount due and payable by the Bank under this guarantee. However, our liability under this guarantee shall be restricted to an amount not exceeding Rs.

3. We, bank undertake to pay to the RailTel any money so demanded notwithstanding any dispute or disputes raised by the Contractor(s) / Supplier(s) in any suit or proceedings pending before any court or Tribunal relating thereto our liability under this present being, absolute and unequivocal.

The payment so made by us under this Bond shall be a valid discharge of our liability for payment there under and the Contractor(s) / Supplier(s) shall have no aim against us for making such payment.

We, Bank further agree that the Guarantee herein contained shall remain in full force and effect during the period that would be taken for the performance of the said Agreement and that it shall continue to be enforceable till all the dues of the RailTel under or by virtue of the said Agreement have been fully paid and its claims satisfied or discharged or till RailTel certifies that the terms and conditions of the said Agreement have been fully and properly carried out by the said Contractor(s) and accordingly discharges this Guarantee. Unless a demand or claim under the Guarantee is made on us in writing on or before the (1) We shall be discharged from all liability under this Guarantee thereafter.

We,.....We,
(indicate the name of Bank) Further agree with the RailTel that the RailTel shall have the fullest liberty without our consent and without affecting in any manner our obligations hereunder to vary any of the terms and conditions of the Agreement or to extend time of to postpone for any time or from time to time any of the powers exercisable by the RailTel against the said contractor(s) and to forbear or enforce any of the terms and conditions relating to the said Agreement and we shall not be relieved from our liability by reason of any such variation, or extension to the said Contractor(s) or for any forbearance, act or omission on the part of RailTel or any indulgence by the RailTel to the said Contractor(s) or by any such matter or thing whatsoever which under the law relating to sureties would, but for this provision, have affect of so relieving us.

This Guarantee will not be discharged due to the change in the Constitution of the Bank or the Contractor(s) Supplier(s).

We, the Bank further agree that this guarantee shall be invokable at our place of business at/New Delhi (indicate detailed address of local New Delhi Branch with code no.). The branch at New Delhi is being advised accordingly.

(indicate the name of Bank) lastly undertaken not to revoke this Guarantee during its currency except with the previous consent of the RailTel in writing.

Dated the day of 2023
for

(Indicate the name of the Bank)

Witness

1. Signature
Name

2. Signature
Name

FINAL SUPPLEMENTARY AGREEMENT

1. Articles of agreement made this day _____ in the year Two thousand and twenty two between the RailTel Corporation of India Limited acting through the _____ RCIL administration having his office at _____, herein after called the Railtel of the one part and _____ of the second part.
2. Whereas the party hereto of the other part executed an agreement with the party hereto of the first part being agreement Number _____ dated _____ for the performance _____ herein after called the 'Principal Agreement'.
3. And whereas it was agree by and between the parties hereto that the works would be completed by the party hereto of the second part on _____ date last extended' and whereas the party hereto of the second part has executed the work to the entire satisfaction of the party hereto of the first part.
4. And whereas the party hereto of the first part already made payment of the party hereto of the second part diverse sums from time to time aggregating to Rs. _____ including the final bill bearing voucher No. _____ dated _____ (the receipt of which is hereby acknowledged by the party hereto of the second part in full and final settlement of all his /its claims under the principal agreement.
And whereas the party hereto of the second part have received further sum of Rs. _____ through the final bill bearing voucher No. _____ dated _____ (the receipt of which is hereby acknowledged by the party thereto of the second part) from the party hereto the first part in full and final settlement of all his/its disputed claims under principal agreement. Now, it is hereby agreed by and between the parties in the consideration of sums already paid (by the party hereto of the first part to the party hereto of the second party against all outstanding dues and claims for, all works done under the aforesaid principal agreement including/excluding the security deposit the party hereto of the second part have no further dues of claims against the party hereto the first part under the said Principal Agreement. It is further agreed by and between the parties that the party hereto of the second part has accepted the said sums mentioned above in full and final satisfaction of all its dues and claims under the said Principal Agreement.
(Applicable in case Final Supplementary Agreement is signed after release of Final Payment)

Or

And whereas the party here to of the first part already made payment to the party here to of the second part diverse sums from time to time aggregating to ₹ _____ through various On Account Bills (the receipt of which is here by acknowledged by the party here to of the second part).

And whereas the party here to of the second part have received sum of ₹ _____ through various On Account Bills (the receipt of which is hereby acknowledged by the party there to of the second part) from the party here to of the first part and party here to of the second part have accepted final measurements recorded on Page No. to Page No of Measurement Book No. And corresponding Final Bill duly adjusted as per price variation clause (PVC), if applicable, for full and final settlement of all his /its disputed claims under principal agreement.

Now, it is hereby agreed by and between the parties in the consideration of sums already paid through various On Account Bills and sums to be paid through Final Bill duly adjusted as per price variation clause (PVC), if applicable, based on accepted final measurements including the security deposit by the party here to of the first part to the party here to of the second part against all outstanding dues and claims for all works done under the aforesaid principal agreement, the party here to of the second part have no further dues of claims against the party here to of the first part under the said Principal Agreement.

(Applicable in case Final Supplementary Agreement is signed before release of Final Payment)

5. It is further agreed and understood by and between the parties that the arbitration clause contained in the said principal agreement shall cease to have any effect and/or shall be deemed to be non-existent for all purposes.

Signature of the contractor/s

for and on behalf of RCIL

Witness:

1. _____

2. _____

ADDRESS: _____



PROFORMA
DECLARATION

I/We hereby solemnly declare that I/We visited the site of the work (as on top sheet) personally and have made myself/ourselves fully conversant of the conditions therein and particular the following:-

1. Topography of area.
2. Soil strata at site of work.
3. Sources and availability of construction materials.
4. Rates for construction of material, water, electricity including all local taxes, royalties, octrois etc.
5. Availability of local labour (both skilled and unskilled) and relevant labour rates and labour laws.
6. The existing roads and approaches to the site of work and requirements for further service roads/approaches to be constructed by me/us
7. The availability and rates of private land etc. that shall be required by me/us for various purposes.
8. Climatic conditions and availability of working days.

I/We have quoted my/our rates for various items in the schedule of items, quantities and rates taking into account all the above factors also.

Signatures of the Tenderer/s

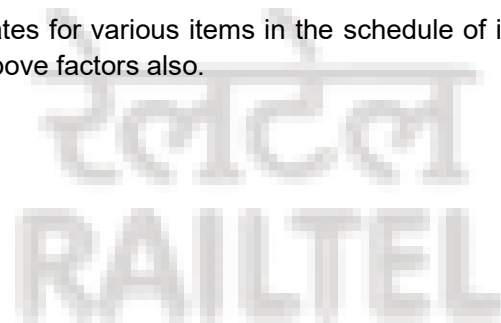

Annexure-D

Constitution of Firm

1	Constitution of the firm/ concern. (Tick as applicable)	Sole Prop./ Partnership Firm/ Company/ JV/Society/LLP/HUF
2	Full name of the Sole Prop./ Partnership Firm/ Company/ JV/Society/LLP/HUF	
3	Year of formation/ incorporation	
4	(a) PAN No.	
	(b) GST No	
5	Registered Office Address	
6	Address on which correspondence regarding this tender should be done	
7	E- mail id	
8	Names of the proprietor/ partners/ JV members etc	

Signature of Tenderer



ANNEXURE – E

Details of Plant and Machinery already available with the firm.

S. No.	Particulars of equipment	No.of Unit.	Kind & make	Capacity	Date by which the plant would be available for use on this work	Age & condition
1	2	3	4	5	6	7

Signature of the Tenderer/s



ANNEXURE -F

List of engineers/personnel already available/ proposed to be employed for deployment on this work:

SN.No.	Name & Designation	Qualification	Professional experience	Organization with whom working	Date by which personnel will be available for this work.
1	2	3	4	5	6

Signatures of Tenderer/s



ANNEXURE-G

Statement of works executed/completed by the tenderer/s during last seven years ending last day of month previous to the one in which tender is invited.

(A) Statement of works executed/completed for RCIL/Railway Govt. Organizations during last 7 years ending last day of the month previous to the one in which tender is invited.

S.No.	Name and place of work	Authority /agency for which work was carried out	Date of award & agreement No. &Date
1	2	3	4

Date of completion (original /actual)	Agreemental cost /completion cost.	Principal /Technical features of the work in brief	S.No. at which relevant certificate /documents are attached.
5	6	7	8

(B) Status of works executed/completed for Public listed companies by the tenderer/s during last 7 years ending last day of the month previous to the one in which tender is invited.

S.No.	Name and place of work	Authority /agency for which work was carried out	Date of award & agreement No. &Date
1	2	3	4

Date of completion (original /actual)	Agreemental cost /completion cost.	Principal /Technical features of the work in brief	S.No. at which work copy of experience certificate, work order, bill of quantities, bill wise details duly certified by Chartered

			Accountant is attached *
5	6	7	8

*** It is certified that:**

1. The above Public listed company/companies mentioned in (B) above is/are
 - a) Having average annual turnover of Rs.500 crore and above in last three financial years excluding the current financial years;
 - b) Listed on National Stock Exchange or Bombay Stock Exchange and
 - c) Incorporated/registered at least 5 years prior to the date of opening of the tender.
2. Copies of the work experience certificate, work orders, bill of quantities, bill wise details of payment received, TDS certificates of all payments received, copy of final bill/last bill paid by the company duly certified are attached.
3. Attached information have been duly certified by Chartered Accountants.
4. I/We understand that in case above details at (B) are not furnished at the time of tendering the work experience certificate shall not be considered for adjudging the Technical Eligibility the tenderer in any case.

Note: Annexure-G to be signed by tenderer/s and Chartered Accountant, if the credentials from Public listed companies (as in case of B above) are being attached for consideration. There is no need of signature of Chartered Accountant, if credentials of any Government organisation are being attached for consideration and in such case only tenderer/s is required to sign on this Annexure -G.

Certified that above details are correct

Signature of the tenderers

Signature of Chartered Accountant with
seal

Signature of the Tenderer/s

ANNEXURE – H

Statement of works being executed/in hand by the contractor/s

S No.	Name and place of work	Authority/agency for whom the work is being carried out*	Date of award & agreement No. & Date	Date of completion (Original/ Extended)
1	2	3	4	5

Agreemental cost of work /likely cost(upto latest corrigendum)	Principal/ Technical features of work in brief	S.No. at which relevant certificate/ Documents are attached	Payment taken till.	Total balance amount of the work to be executed	Net balance amount of the work to be executed during the period of completion of proposed work i.e. during next 'N' years
6	7	8	9	10	11

N= Number of years prescribed for completion of work for which bid has been invited.

*The above statement should include all on going works with the tenderer / constituents of tendering JV in its individual capacity as well as their portion of work in JV / Consortium.

Signature of Chartered Accountant with seal

Signature of the tenderers

CERTIFICATE OF CONTRACTUAL PAYMENT FROM CHARTERED ACCOUNTANT.

Details of contractual payments received by the tenderer / constituent of tendering JV during the qualifying period i.e during the current financial year plus previous three financial years.

Name of the Tenderer / constituent of tendering JV:- _____

Year	<i>Amount of Contractual Payments received</i>	Basis of contractual payment received (Audited Balance Sheet ** or Form 16A /26AS from IT TRACES or Certificates from concerned Department / Client*) #
Current financial year	<i>Rs..... FY/.....</i>	
3rd Previous financial year	<i>Rs..... FY/.....</i>	
2nd Previous financial year	<i>Rs..... FY/.....</i>	
1st Previous financial year	<i>Rs..... FY/.....</i>	
Total		

*Client certificate from other than Govt. Organisation should be duly supported by Form 16A/26AS generated through TRACES of IT Department.

The Audited Balance Sheet or Form 16A /26AS from IT TRACES or Certificates from concerned Department / Client as referred for contractual payments received should be submitted alongwith the tender failing which payment received shall not be considered.

** In case the figure of contractual payment is not directly available in Audited Balance Sheet, the CA should obtain this figure from the Audited Account based on which the Balance Sheet has been prepared.

Signature of Chartered Accountant

- [i] Name :-
- [ii] Address:
- [iii] Phone No:-
- [iv] Membership No.
- [v] e-mail ID:-

Name and signature of Tenderer / Constituent Member of tendering JV

FORMS

FORM NO. E-5

Appendex-VIII

Real Time Gross Saving (RTGS)/National Electronic Fund Transfer (NEFT)
Model Mandate Form

(Investor/customer's option to receive payments through RTGS/NEFT)

1. Investor/customer's name

2. Particular's of Bank Account:

A) Name of the Bank:

B) Name of the Branch.

Address

Telephone No.

C) RTGS/NEFT IFS Code.

D) Type of the account (S.B. Current or Cash Credit)
With code (10/11/13).

E) Ledger and Ledger folio number.

F) Account number (as appearing on the Cheque book) in lieu of the bank certificate to be obtained as under,
please attach a blank cancelled cheque or a photocopy of a cheque or front page of your savings bank pass book issued by your bank for verification of the above particulars)

3. Date of effect

I hereby declare that the particulars given above are correct and complete. If the transaction is delayed or not effected at all for reasons of incomplete or incorrect information, I would not hold the user institution responsible. I have read the option invitation letter and agree to discharge the responsibility expected of me as a participant under the scheme.

(.....)

Signature of the Investor/ Customer

Date

Certified that he particulars furnished above are correct as per our records.
Bank's Stamp

GUIDELINES' FOR PARTICIPATION OF JOINT VENTURE (JV) FIRMS

(THE JV firms are allowed to participate only in the tenders of value more than Rs. 10 crores).

1. Separate identity/name shall be given to the Joint Venture firm.
2. Number of members in a JV shall not be more than three if the work involves only one department (say Civil or S&T or Electrical or Mechanical) and shall not be more than five, if the work involves more than one department. One of the members of the JV shall be its Lead Member who shall have a majority (at least 51%) share of interest in the JV. The other members shall have a share of not less than 20% each in case of JV with upto three members and not less than 10% each in case of JV with more than three members. In case of JV with foreign member(s), the Lead Member has to be an Indian firm/company with a minimum share of 51%.
3. A member of JV firm shall not be permitted to participate either in individual capacity or as a member of another JV firm **in the same tender**.
4. The tender form shall be purchased and submitted only in the name of the JV and not in the name of any constituent member. The tender form can however be submitted by JV or any of its constituent member or any person authorized by JV through Power of Attorney to submit tender
5. Earnest Money Deposit (EMD) shall be deposited by JV or authorized person of JV through e-payment gateway or as mentioned in tender document.
6. A copy of Memorandum of Understanding (MOU) duly executed by the JV members on a stamp paper, shall be submitted by the JV firm along with the tender. The complete details of the members of the JV firm, their share and responsibility in the JV firm etc. particularly with reference to financial, technical and other obligations shall be furnished in the MOU. (The MOU Format for this purpose is enclosed as Annexure K1).
7. Once the tender is submitted, the MOU shall not be modified/alterd/terminated during the validity of the tender. In case the tenderer fails to observe/comply with this stipulation, the full Earnest Money Deposit (EMD) shall be forfeited.
8. Approval for change of constitution of JV firm shall be at the sole discretion of the Employer (RCIL/Railways). The constitution of the JV firm shall not be allowed to be modified after submission of the tender bid by the JV firm, except when modification becomes inevitable due to succession laws etc. and in any case the minimum eligibility criteria should not get vitiated. However, the Lead Member shall continue to be the Lead Member of the JV Firm. Failure to observe this requirement would render the offer invalid.
9. Similarly, after the contract is awarded, the constitution of JV firm shall not be allowed to be altered during the currency of contract except when modification become inevitable due to succession laws etc. and in any case the minimum eligibility criteria should not get vitiated. Failure to observe this stipulation shall be deemed to be breach of contract with all consequential penal action as per contract conditions.
10. On award of contract to a JV firm, a single Performance Guarantee shall be submitted by the JV Firm as per tender conditions. All the Guarantee like performance Guarantee, Bank Guarantee for Mobilization Advance, Machinery Advance etc shall be accepted only in the name of the JV Firm and no splitting of guarantees amongst the members of the JV Firm shall be permitted.

11. On issue of LOA (Letter of Acceptance), the JV entity to whom the work has been awarded, shall form a legal entity if not already formed, which shall have the same shareholding pattern, as was declared in the MOU/JV Agreement submitted alongwith the tender. This entity shall be got registered before the Registrar of the Companies under 'The Companies Act 2013' (in case of Company) or before the Registrar/Sub-Registrar under the 'Registration Act, 1908' (in case of Partnership Firm) or under 'The LLP Act 2008' (in case of LLP). A separate PAN shall be obtained for this entity. The documents pertaining to this entity including its PAN shall be furnished to the RCIL before signing the contract agreement for the work. In case the tenderer fails to observe/comply with this stipulation within 60 days of issue of LOA, contract is liable to be terminated. In case contract is terminated REL shall be entitled to forfeit the full amount of the Earnest Money Deposit and other dues payable to the Contractor under this contract. This The entity so registered, in the registered documents shall have, inter-alia, following Clauses:

11.1 Joint And Seveal Liability: Members of the registered entity to which the contract is awarded, shall be jointly and severally liable to the Employer (RCIL/Railways) for execution of the project in accordance with General and Special Conditions of the Contract. The JV members shall also be liable jointly and severally for the loss, damages caused to the RCIL/Railways during the course of execution of the contract or due to non-execution of the contract or part thereof.

11.2 Duration of the registered entity: It shall be valid during the entire currency of the contract including the period of extension, if any, and the maintenance period after the work is completed.

11.3 Governing Laws: Registered entity shall in all respect be governed by and interpreted in accordance with Indian Laws.

12. Authorized Member: Joint Venture Members shall authorize one of the members on behalf of the Joint Venture Firm to deal with the tender, sign the agreement or enter into contract in respect of the said tender, to receive payment, to witness joint measurement of work done, to sign measurement books and similar such action in respect of the said tender/contract. All notices/correspondences with respect to the contract would be sent only to this authorized member of the JV Firm.

13. No member of the Joint Venture firm shall have the right to assign or transfer the interest right or liability in the contract without the written consent of the other members and that of the Employer (RCIL/Railways) in respect of the said tender/contract.

14. Documents to be enclosed by the JV firm along with the tender:

14.1 In case one or more of the members of the JV firm is/are partnership firm(s), following documents shall be submitted:

- (a) A notarized copy of Partnership Deed.
- (b) A copy of consent of all the partners or individual authorized by partnership firm, to enter into the Joint Venture Agreement on a stamp paper
- (c) A copy of Power of Attorney (duly registered) in favour of the individual to sign the MOU/JV Agreement on behalf of the partnership firm and create liability against the firm.

14.2 In case one or more members is/are Proprietary Firm or HUF, the following documents shall be enclosed:

A copy of notarized affidavit on Stamp Paper declaring that he who is signing the on behalf of HUF is in the position of 'Karta' of Hindu Undivided (HUF) and he authority, power and consent given by other members to act on behalf of HUF.

14.3 In case one or more members is/are limited companies, the following documents shall be submitted :

- (a) A copy of resolutions of the Directors of the Company, permitting the company to enter into a JV agreement.
- (b) The Copies of Memorandum and Articles of Association of the Company.
- (c) A copy of certificate of incorporation.
- (d) A copy of Authorization/copy of Power of Attorney issued by the Company (backed by the resolution of Board of Directors) in favour of the individual to sign the tender, sign MOU/JV Agreement on behalf of the company and create liability against the company

14.4 In case one or more member(s) of JV firm is/are LLP firm(s) following document shall be submitted:

- (a) A notarised copy of certificate of incorporation and LLP agreement.
- (b) A notarised copy of resolution of the partners of LLP, permitting the LLP to enter into a JV agreement, authorising one of the partners of LLP to sign JV MOU/agreement and such other documents required to be signed on behalf of the LLP and to create liability against the LLP and/or to do any other act on behalf of LLP
- (c) A copy of authorisation/copy of power of attorney issued by the LLP (backed by resolution of partners) in favour of individual to sign the tender, sign MOU/JV agreement on behalf of the LLP and create liability against the LLP.

14.5 All the members of the JV shall certify that they are not black listed or debarred by RCIL/Railways or any other Ministry/ Department/PSU (Public Sector undertaking) of the Govt. of India/State Govt. from participation in tenders/contract on the date of opening of bids either in their individual capacity or as a member of the JV firm in which they were/are members.

15. Credentials & Qualifying criteria

Technical, financial eligibility and Bid capacity of the JV shall be adjudged based on satisfactory fulfillment of the following criteria:

15.1 Technical eligibility criteria ('a' or 'b' mentioned hereunder):

- a) For Works without composite components

The technical eligibility for the work as per para 2.3.2A(v) above, shall be satisfied by either the 'JV in its own name & style' or any member having min 26% share. Each other member of JV shall have technical capacity of minimum 10% of the cost of work.

- (b) For works with composite components

- (i) The technical eligibility for each component of work as per para 2.3.2A(v) above, shall be satisfied by either the 'JV in its own name & style' or any member having min 26% share. Each other member of JV shall have technical capacity of minimum 10% of the cost of any component of work.

OR

- (ii) The technical eligibility for major component of work as per para 2.3.2A(v) above, shall be

satisfied by either the 'JV in its own name & style' or any member having min 26% share and technical eligibility for other components of work as per para 2.3.2A(v) above, shall be satisfied by either the 'JV in its own name & style' or 'any member of the JV'. Each other member of JV shall have technical capacity of minimum 10% of the cost of any component of work.

Note:

- (a) The Major component of the work for this purpose shall be the component of work having highest value. In cases where value of two or more component of work is same, any one work can be classified as Major component of work.*
- (b) Value of a completed work done by a Member in an earlier JV shall be reckoned only to the extent of the concerned member's share in that JV for the purpose of satisfying his/her compliance to the above mentioned technical eligibility criteria in the tender under consideration*

15.2 Financial eligibility criteria:

The JV shall satisfy the requirement of "Financial Eligibility" mentioned at para 2.3.2A (v) above. The "financial capacity" of the lead partner of JV shall not be less than 51% of the financial eligibility criteria mentioned at para 2.3.2A(v) above. The "financial capacity" of each of other partners (excluding lead partner) shall not be less than 10% of the financial eligibility criteria mentioned at para 2.3.2A(v) above.

The arithmetic sum of individual "financial capacity" of all the members shall be taken as JV's "financial capacity" to satisfy this requirement

NOTE: Contractual payment received by a Member in an earlier JV firm shall be reckoned only to the extent of the concerned member's share in that JV firm for the purpose of satisfying compliance of the above mentioned financial eligibility criteria in tender under consideration.

16. Bid Capacity

The JV shall satisfy the requirement of "Bid Capacity" requirement mentioned at para 2.3.2(A)(xiv) above. The arithmetic sum of individual "Bid capacity" of all the members shall be taken as JV's "Bid capacity" to satisfy this requirement

FORMAT FOR JOINT VENTURE MEMORANDUM OF UNDERSTANDING/ AGREEMENT.

THIS JOINT VENTURE MEMORANDUM OF UNDERSTANDING (MOU) AGREEMENT EXECUTED AT on thisday of between M/s Registered office atas the first party M/s Registered office at..... as the second party M/s Registered office at..... as the Third party (The expression and words of the first and second and third party shall mean and include their heirs successors, assigns, nominees execution, administrators and legal representatives respectively.)

WHEREAS all the parties are engaged in the business of execution of Civil Engineering and General Contracts for various Government Departments and organizations.

WHEREAS the parties herein above mentioned are desirous of entering into a Joint Venture for carrying on Engineering and/or contract works in connection with and other works mentioned in Tender Notice No..... dated of RCIL or any other work or works, as mutually decided between the parties to this Joint Venture.

WHEREAS all the parties are desirous of recording the terms and conditions of this Joint Venture to avoid future disputes.

NOW THIS MOU/AGREEMENT WITNESSTH AS UNDER:

1. That in and under this Joint Venture agreement the work will be done jointly by the First party and Second party in the name and style of M/s (Joint Venture of M/s M/s..... and M/s)
2. That all the parties shall be legally liable, severally and or jointly responsible for the satisfactory/successful execution/completion of the work in all respects and in accordance with terms and conditions of the contract.
3. That the role of each constituent of the said Joint Venture in details shall be as under:
The first party shall be responsible for
The second party shall be responsible for
The third party shall be responsible for
4. The share of profit and loss of each constituent of the said Joint Venture shall be as under :
 6. Lead partner share = ----% (At least 51%)
 7. 2nd Joint Venture Partner share = -----%
 8. 3rd Joint Venture partner share = -----%
 9. 4thJoint Venture partner share = -----%] in case of
 10. 5th Joint Venture partner share = -----%] composite tender
5. That all the parties of this Joint Venture shall depute their experienced staff as committed commensurating with their role and responsibility and as required for the successful completion of the works in close consultation with each other.

6. That the investment required for the works under this Joint Venture shall be brought in by the parties as agreed to between them from time to time.
7. That all the Bank Guarantee shall be furnished jointly by the parties in the name of Joint Venture.
8. That the party number..... to this Joint Venture shall be the prime (lead) contractor and will be responsible for timely completion of work and to co-ordinate with the RCIL to receive payments and also to make all correspondence on behalf of this Joint Venture.
9. That all the above noted parties i.e. not to make any change in the agreement without prior written consent of the RCIL .
NOW, the parties have joined hands to form this Joint Venture on this
Day of two thousandwith reference to and in confirmation of their discussions and understanding brought on record on

IN WITNESS THEREOF, all /both the above named parties have set their respective hands onthe day and year First above mentioned in the presence of the following witness:

WITNESSES:

1. First party.
5. That all the parties of this Joint Venture shall depute their experienced staff as committed commensurating with their role and responsibility and as required for the successful completion of the works in close consultation with each other.
6. That the investment required for the works under this Joint Venture shall be brought in by the parties as agreed to between them from time to time.
7. That all the Bank Guarantee shall be furnished jointly by the parties in the name of Joint Venture.
8. That the party number..... to this Joint Venture shall be the prime (lead) contractor and will be responsible for timely completion of work and to co-ordinate with the to receive payments and also to make all correspondence on behalf of this Joint Venture.
9. That all the above noted parties i.e. not to make any change in the agreement without prior written consent of the .
NOW, the parties have joined hands to form this Joint Venture on this
Day of two thousandwith reference to and in confirmation of their discussions and understanding brought on record on

IN WITNESS THEREOF, all /both the above named parties have set their respective hands onthe day and year First above mentioned in the presence of the following witness:

WITNESSES:

1. First party.
2. Second party



Guidelines for submitting tenders by Partnership Firms and their Eligibility Criteria

1. The Partnership Firms participating in the tender should be legally valid under the provisions of Indian Partnership Act.
2. The partnership firm should have been in existence or should have been formed prior to submission of tender. Partnership firm should have been registered with the Registrar of firms and the partnership deed should have been notarized prior to date of tender opening as per the Indian Partnership Act. **Tenderer shall upload** document(s) in support of registration of firm with registrar of firms viz which includes Certificate of registration and copy of Register of firm (Form No. may vary from State to State) (as applicable) etc. issued by Registrar of firms.
3. Separate identity/name should be given to the partnership firm. The partnership firm should have PAN/ TAN number in its own name and PAN/TAN number in the name of the any of the constituent partners shall not be considered. The valid constituents of the firm shall be called partners.
- 4.1. Once the tender has been submitted, the constitution of firm shall not normally be allowed to be modified/alterd/terminated during the validity of the tender as well as the currency of the contract except when modification becomes inevitable due to succession laws etc, in which case prior permission should be taken from RCIL/ and in any case the minimum eligibility criteria should not get vitiated. The reconstitution of firm in such cases should be followed by a notary certified Supplementary Deed. The approval for change of constitution of the firm, in any case, shall be at the sole discretion of the RCIL and the tenderer shall have no claims what so ever. Any change in the constitution of Partnership Firm after opening of tender shall be with the consent of all partners and with the signatures of all partners as that in the Partnership deed. Failure to observe this requirement shall render the offer invalid and full EMD shall be forfeited.
- 4.2 If any partner/s withdraw from the firm after opening of the tender and before the award of the tender, the offer shall be rejected and EMD of the tenderer will be forfeited. If any new partner joins the firm after opening of tender but prior to award of contract, his/her credentials shall not qualify for consideration towards eligibility criteria either individually or in proportion to this share in the previous firm. In case the tenderer fails to inform RCIL beforehand about any such changes/modification in the constitution which is inevitable due to succession laws etc. and the contract is awarded to such firm, then it will be considered a breach of contract conditions, liable for determination of contract under Clause 62 of General Condition of Contract.
- 4.3 A partner of the firm shall not be permitted to participate either in his individual capacity or as a partner of any other firm in the same tender.
- 4.4 The tender form shall be submitted only in the name of partnership firm. Bid Security Declaration shall be submitted on IREPS (Refer detailed instructions at Annexure-T) **OR** the EMD (Earnest Money Deposit) shall be deposited by partnership firm through e payment gateway along with the tender in terms of the provisions contained in clause **3.0 (Earnest Money)** of tender document, as applicable.
5. One or more of the partners of the firm or any other person(s) shall be designated as the authorized person(s) on behalf of the firm, who will be authorized by all the partners to act on behalf of the firm through a "Power of Attorney", specifically authorizing him/them to submit & sign the tender, sign the agreement, receive payment, witness measurements, sign measurement books, make correspondences, compromise, settle, relinquish any claim(s) preferred by the firm, sign "No Claim Certificate" , refer all or any dispute to arbitration and to take similar such action in

respect of the said tender/contract. Such "Power of Attorney" should be **Notarized/Registered** submitted/uploaded along with tender.

6. On issue of Letter of Acceptance (LOA) to the partnership firm, all the guarantees like Performance Guarantee, Guarantee for various Advances to the Contractor shall be submitted only in the name of the partnership firm and no splitting of guarantees among the partners shall be acceptable

7. On issue of Letter of Acceptance (LOA), contract agreement with partnership firm shall be executed in the name of the firm only and not in the name of any individual partner.

8. In case, Letter of Acceptance (LOA) is issued to a partnership firm, the following undertakings shall be furnished by all the partners through a notarized affidavit, before signing of contract agreement:-

(a)Joint and several liabilities – The partners of the firm to which the Letter of Acceptance (LOA) is issued, shall be jointly and severally liable to the RCIL for execution of the contract in accordance with general and special conditions of the contract. The partners shall also be liable jointly and severally for the loss, damages caused to the RCIL during the course of execution of the contract or due to non-execution of the contract or part thereof.

(b)Duration of the partnership deed and partnership firm agreement – The partnership deed/partnership firm agreement shall normally not be modified, altered, terminated during the currency of contract and the maintenance period after the work is completed as contemplated in the conditions of the contract. Any change carried out by partners in the constitution of the firm without permission of RCIL, shall constitute a breach of contract liable for determination of contract under clause 62 of General Conditions of Contract.

(c)Governing Laws – The partnership firm agreement shall in all respect be governed by and interpreted in accordance with the Indian laws.

(d) No partner of the firm shall have the right to assign or transfer the interest right or liability in the contract without the written consent of the other partner and that of the RCIL.

9. The tenderer shall clearly specify that the tender is submitted on behalf of a partnership concern. The following documents shall be submitted by the partnership firm, with the tender-

(a) Tenderer shall upload document(s) in support of registration of firm with registrar of firms which includes Certificate of registration and Register of firm (Form No. may vary from State to State)(as applicable) etc. issued by Registrar of firms. Tenderer shall also upload Notary certified of Partnership Deed-

(b) A copy of Power of Attorney (**Notarized or Registered**) in favour of the individual to tender for the work, sign the agreement etc. and create liability against the firm.

(c) An undertaking by all the partners of the partnership firm that they are not black listed or debarred by RCIL or any other Ministry/Department of the Govt of India/any State Govt from participation in tenders/contract as on the date of opening of bids either in their individual capacity or in any firm in which they were/are partners. Concealment/wrong information in regard to above shall make the contract liable for determination under clause 62 of General Conditions of Contract.

10.0 Evaluation of eligibility of a partnership firm:

Technical and financial eligibility of the firm shall be adjudged based on satisfactory fulfillment of the eligibility criteria laid down in Clause 2.3.2A(v) &(vi) of eligibility criteria by the partnership firm.



DECLARATION BY AN EXISTING PARTNERSHIP FIRM

(Fill the relevant para (1.1, 1.2 & 1.3) and strike off the para which is not relevant under Partnership Firm)

1.0 I.....S/o Shri, the authorized signatory of partnership firm M/s.....do hereby solemnly affirm and declare as under:

1.1 That, we are an existing Partnership Firm in the name and style of M/s -----, since -----(MM/YY), having GST Registration no. -----, PAN/TAN No.----- . There has been no change in the Partner(s) of our firm during last 07 (Seven) years ending last day of the month previous to the one in which tender is invited.

OR

1.2 That, we are an existing Partnership Firm in the name and style of M/s ----- -, since -----(MM/YY), having GST Registration no. -----, PAN/TAN No.----- . Following of our partner(s) has/have quit the Partnership firm during last 07 (Seven) years ending last day of the month previous to the one in which tender is invited with details as under:

S.No.	Name of quitting Partner(s)	Share of Partner(s) who has/have quitted	Date of quitting (MM/YY)

AND / OR

1.3 That, we are an existing Partnership Firm in the name and style of M/s ----- -, since -----(MM/YY), having GST Registration no. -----, PAN/TAN No.----- . Following partner(s) has/have joined our Partnership Firm during last 07 (Seven) years ending last day of the month previous to the one in which tender is invited with details as under:

S.No.	Name of joining Partner(s)	Share of joining Partner(s)	
		In the present firm	In the previous firm from where he/they has/have quit and joined the present firm

1.4 In case of Para 1.2 and 1.3 , following documents as applicable are required to be submitted alongwith bid:-

- (i) Copy of previous Partnership Deed(s).
- (ii) Copy of Dissolution Deed(s) of previous partnership deed(s).
- (iii) Proof of surrender of PAN No(s) (in case of dissolution of previous partnership firm).

Declaration by the Tenderer:-

I hereby declare that the information given above are true. If any of the above information is found to be wrong at any time, my tender will be liable to be rejected.

Name and Signature of tenderer
along with Seal

DECLARATION BY NEWLY FORMED PARTNERSHIP FIRM

I.....S/o Shri, the authorized signatory of partnership firm M/s.....do hereby solemnly affirm and declare as under:

1. That, we are the newly formed partnership firm in the name and style of M/s.....Registered with Registrar of firm vide Registration No....., dated
2. In this newly formed Partnership Firm, we areno. of partners. The details of the previous proprietary firm or previous dissolved partnership firm or previous splitted partnership firm(s) wherein any of the partners of the present firm was a proprietor / partner and proposed to use credentials obtained in such previous propriety firm (s) / partnership firm(s) is as under:-

S.N.	Name of person in the newly formed partnership firm	Details of Previous proprietary/ Partnership Firm	Share in newly formed partnership firm	Share in previous partnership firm	Remarks
1.					
2.					
3.					

3. That, following relevant documents are Annexed with bid:-
 - (i) Copy of previous Partnership Deed(s).
 - (ii) Copy of previous Dissolution/splitting Deed(s) of previous partnership deed(s).
 - (iii) Proof of surrender of PAN No(s) (in case of dissolution of partnership firm).

Declaration by the Tenderer:-

I hereby declare that the information given above are true. If any of the above information is found to be wrong at any time, my tender will liable to be rejected.

Name and Signature of tenderer
along with Seal

Annexure-L

RailTel Corporation of India Limited/ Delhi.
(Standard Format)

COMPLETION CERTIFICATE

The work of "----- (Full name of the work) -----" has been
Completed with following details:-

1	Name & complete address of the contractor.	
2	Nature of entity (sole prop/ partnership firm/ company / JV)	
3	In case of Sole proprietorship, the name of sole proprietor	
(a)		
(b)	In case of partnership firm/JV, the names & shares of various partners/ members.	
4	Date of Acceptance/LOA	
5	Agreement No. & date	
6 i)	Original Agreement Cost	
ii)	Final Agreement Cost	
7	Total payment made along with financial year-wise break-up	
8	Original date of completion (DOC)	
9	(a)Actual date of completion (b)Whether extension to DOC given with penalty or without penalty	
10	Brief description of nature & scope of work	
11	Performance of contractor (Satisfactory/unsatisfactory)	

It is certified that the above work has been completed successfully in accordance with provisions of contract.

Name & Signature
Issuing authority with seal

Date of issue of certificate: -----
Case File No.:-----

FORMAT FOR AFFIDAVIT TO BE UPLOADED BY TENDERER ALONGWITH THE TENDER DOCUMENTS

(to be executed non judicial stamp paper of appropriate value as per law of state concerned- Non Judicial stamp paper should be purchased in the name of partners of the firm)

I..... (Name and designation)** appointed as the attorney/authorized signatory of the tenderer (including its constituents),

M/s _____ (hereinafter called the tenderer) for the purpose of the Tender documents for the work of _____ as per the tender No. _____ of RCIL, do hereby solemnly affirm and state on the behalf of the tenderer including its constituents As under:

1. I/we the tenderer (s), am/are signing this document after carefully reading the contents.
1. I/We the tenderer(s) also accept all the conditions of the tender and have signed all the pages in confirmation thereof.
2. I/we hereby declare that I/we have downloaded the tender documents from Indian Railway website www.ireps.gov.in. I/we have verified the content of the document from the website and there is no addition, no deletion or no alteration to the content of the tender document. In case of any discrepancy noticed at any stage i.e. evaluation of tenders, execution of work or final payment of the contract, the master copy available with the RCIL Administration shall be final and binding upon me/us.
3. I/we declare and certify that I/we have not made any misleading or false representation in the forms, statements and attachments in proof of the qualification requirements.
4. I/We also understand that my/our offer will be evaluated based on the documents/credentials submitted along with the offer and same shall be binding upon me/us.
5. I/We declare that the information and documents submitted along with the tender by me/us are correct and I/we are fully responsible for the correctness of the information and documents, submitted by us.
6. I/we understand that if the certificates regarding eligibility criteria submitted by us are found to be forged/false or incorrect at any time during process for evaluation of tenders, it shall lead to forfeiture of the tender EMD besides banning of business for a period of upto five year. Further, I/we (*insert name of the tenderer*)** _____ and all my/our constituents understand that my/our offer shall be summarily rejected.
7. I/we also understand that if the certificates submitted by us are found to be false/forged or incorrect at any time After the award of the contract, it will lead to termination of the contract, alongwith forfeiture of EMD/SD and Performance guarantee besides any other action provided in the contract including banning of business for a period of upto five year.

SEAL AND SIGNATURE
OF THE TENDERER

Place:

Dated:

**The contents in Italics are only for guidance purpose. Details as appropriate, are to be filled in suitably by tenderer.

CERTIFICATE OF CONTRACTUAL PAYMENT FROM CHARTERED ACCOUNTANT.

For evaluation of Bid Capacity (Maximum value of Contractual payment received in any one year during the last three years and current financial year)

Details of contractual payments received by the tenderer / constituent of tendering JV during the qualifying period i.e during the current financial year plus previous three financial years.

Name of the Tenderer / constituent of tendering JV: _____

Year	Amount of Contractual Payments received	Basis of contractual payment received (Audited Balance Sheet ** or Form 16A /26AS from IT TRACES or Certificates from concerned Department / Client*) #	
3rd Previous financial year	Rs..... FY/.....		
2nd Previous financial year	Rs..... FY/.....		
1st Previous financial year	Rs..... FY/.....		
Current financial year	Rs..... FY/.....		
Total			

*Client certificate from other than Govt. Organisation should be duly supported by Form 16A/26AS generated through TRACES of IT Department.

The Audited Balance Sheet or Form 16A /26AS from IT TRACES or Certificates from concerned Department / Client as referred for contractual payments received should be submitted alongwith the tender failing which payment received shall not be considered.

** In case the figure of contractual payment is not directly available in Audited Balance Sheet, the CA should obtain this figure from the Audited Account based on which the Balance Sheet has been prepared.

Signature of Chartered Accountant

- [i] Name :-
- [ii] Address:
- [iii] Phone No:-
- [iv] Membership No.
- [v] e-mail ID:-

Name and signature of Tenderer / Constituent Member of tendering JV

UNDERTAKING BY SOLE PROPRIETORSHIP FIRM

I.....S/o Shri aged about years
R/o.....do hereby solemnly affirm
and declare as under:

1. That I am running a business in the name and style of M/S..... which is a sole proprietorship firm and which has got GST registration No.....
2. That I am the sole proprietor of the said firm M/S
3. That the Head office of the above named firm is situated at.....
4. That I/ my Firm is not blacklisted or debarred by Railway/RCIL or any other Ministry / Department of Govt. of India from participation in tender on the date of opening of bids, either in individual capacity or as a member of the partnership firm or JV in which he was / is a partner/member. Concealment / wrong information in regard to above shall make the contract liable for determination under Clause 62 of the General Conditions of Contract.

Signature of tenderer



POWER-OF-ATTORNEY FOR SIGNING OF BID ON BEHALF OF PARTNERSHIP FIRM

(to be executed non judicial stamp paper of appropriate value as per law of state concerned- Non Judicial stamp paper should be purchased in the name of partners of the firm)

KNOW ALL MEN BY THESE PRESENTS: WHEREAS WE

(1)..... S/oShri..... R/o.....

(2)..... S/oShri..... R/o.....

(3)..... S/o Shri..... R/o.....

(4)..... S/o Shri..... R/o.....

all are the partners of a partnership firm namely M/S.....
(Name of firm) hereinafter referred to as 'firm', which is registered at Registration No.....by Registrar of Firms..... The firm is having its head office at..... (hereinafter to be referred as the 'Firm').

AND WHEREAS we all the above named partners have on.....(date) given our consent on behalf of firm to participate in the tender No. _____ issued by RCIL for the work namely " _____ "

We the above named partners of above named firm do hereby irrevocably constitute, nominate, appoint and authorize Mr./ Ms. _____ S/o Shri _____ (address) _____ & Mr./ Ms. _____ S/o Shri _____ (address) _____ as our true and lawful attorney (hereinafter referred to as "Attorney") of the firm to jointly or severally exercise all or any of the following powers for and on behalf of M/S (name of firm) in connection with aforesaid bid:

1. To sign and submit Tender and participate in the aforesaid bid of the RCIL on behalf of the firm.
2. To sign and submit all the necessary papers, letters, forms, quotes, bids etc. on behalf of firm.
3. To negotiate, discuss, agree to make any amendments, alterations or modifications thereto and to make representations, submit papers, affidavits and to do any other act and complete requisite formalities on behalf of the firm in connection with completion of aforesaid tender work and to enter into liability against the firm.
4. To sign, execute the contract with RCIL for and on behalf of the firm.
5. And generally to do all such acts, deeds or things as may be necessary or proper for the purposes mentioned above.

We on behalf of firm undertake that it shall not cancel or amend this power of Attorney without obtaining previous written consent of RCIL .

We on behalf of firm hereby agree that all acts, deeds or things lawfully done by the said Attorneys or either of them under the authority of this power shall be construed as acts, deeds and things done by the firm and we hereby undertakes to confirm and ratify all and whatsoever the said

Attorneys or either of them shall lawfully do or cause to be done by virtue of the powers hereby given.

That we/our Firm is not blacklisted or debarred by RCIL/RAILWAY or any other Ministry / Department of Govt. of India from participation in tender / contracts as on the date of opening of bids, either in their individual capacity or in any firm in which they were / are partners. Concealment / wrong information in regard to above shall make the contract liable for determination under Clause 62 of the General Conditions of Contract.

Specimen signatures of the Attorney are appended below.

IN WITNESS WHEREOF this deed has been signed and sealed by us the under named, on this..... day of..... 20.... , in presence of:

WITNESSES:

1. Signature Name: Address:	Executants Partners (Name) (Signature) 1..... 2..... 3..... 4.....
2. Signature Name: Address:	

Specimen Signatures of Attorney Holder(s) in token of acceptance:

(1) Name..... Signature.....

(2) Name..... Signature.....

Executed and Signed before me on this.....day of At(place).

(seal and signature of Notary Public)

Notes:

1. In this format space has been provided for entering details of four partners& two attorney holders however if the number vary details may accordingly be entered.
2. The document should be notarized at its place of execution (Place of signing the document).
3. Each page of the document should be signed by executants.
4. The power of attorney should be Notarized/ Registered.

POWER-OF-ATTORNEY ON BEHALF OF THE JOINT VENTURE

(to be executed non judicial stamp paper of appropriate value as per law of state concerned- Non Judicial stamp paper should be purchased in the name of the members of Joint Venture)

KNOW ALL MEN BY THESE PRESENTS THAT WE THE PARTIES whose details are given here under:

1.(name of constituent).....(address) as the first party.
2.(name of constituent).....(address) as the second party.

Have entered into a Joint Venture agreement for the purpose of securing the work advertised by RailTel Corporation of India Limited vide NIT No.....details of works are as under:

“.....”

The aforesaid Joint Venture shall be known by the name “.....” (Hereinafter called the Joint Venture which Expression shall unless repugnant to the context or meaning thereof, include its successors, administrators and assigns.

We the above said parties, through this power of Attorney do hereby irrevocably constitute, nominate, appoint and authorize Mr./ Ms. _____ S/o Shri _____ (address) who is presently holding the position of _____ in _____ the firm/ company as our true and lawful attorney (hereinafter referred to as “Attorney”) of the Joint Venture under whose digital signature key the tender document shall be uploaded on behalf of JV. to jointly or severally exercise all or any of the following powers for and on behalf of “..... (name of JV) in connection with aforesaid bid:

1. To sign and submit Tender and participate in the aforesaid bid of the RCIL on behalf of the Joint Venture.
2. To sign and submit all the necessary papers, letters, forms, quotes, bids etc. on behalf of Joint Venture
3. To negotiate, discuss, agree to make any amendments, alterations or modifications thereto and to make representations, submit papers, affidavits and to do any other act and complete requisite formalities on behalf of the Joint Venture in connection with completion of aforesaid tender work and to enter into liability against the Joint Venture.
4. To sign, execute the contract with RCIL for and on behalf of the Joint Venture.
5. And generally to do all such acts, deeds or things as may be necessary or proper for the purposes mentioned above on behalf of Joint Venture.

The Joint Venture agrees and undertakes that in the event of any change in the constitution of the Joint Venture the rights and obligations of the Joint Venture shall continue to be in full force without any effect thereof.

We all the members of Joint Venture undertake that we shall not cancel or amend this Power of Attorney unilaterally and without prior written consent of RCIL.

AND the Joint Venture hereby agrees that all acts, deeds or things lawfully done by the said Attorneys or either of them under the authority of this power shall be construed as acts, deeds and things done by the Joint Venture and the Company hereby undertakes to confirm and ratify all and whatsoever the said Attorneys or either of them shall lawfully do or cause to be done by virtue of the powers hereby given.

IN WITNESS WHEREOF the members constituting the Joint Venture as aforesaid have executed these present, on this..... day of..... 20.... , under the common seal(s)/seals of their companies and/or firms(s), in presence of:

WITNESSES:

1. Signature
Name:
Address:

Signature of authorized signatories & their
Seals:

1. First Party (signature)
Name:
Seal

2. Signature
Name:
Address:

2. Second Party (signature)
Name:
Seal

Specimen Signatures of Attorney Holder in token of acceptance:

Name.....Signature.....

Executed and Signed before me on this.....day of At
.....(place).

(seal and signature of Notary Public)

Notes: 1. In this format space has been provided for entering details of two constituents of the JV however if the number vary the details may accordingly be entered.

2. The document should be notarized at its place of execution (Place of signing the document)..

3. Each page of the document should be signed by executants.

**CONSENT OF PARTNERS OF PARTNERSHIP FIRM FOR SIGNING JOINT VENTURE
(to be executed on non-judicial stamp paper as per tender conditions-Non Judicial
stamp paper should be purchased in the name of partners of the firm)**

KNOW ALL MEN BY THESE PRESENTS: WHEREAS WE :

- (1)..... S/o Shri..... R/o.....
- (2)..... S/oShri..... R/o.....
- (3)..... S/oShri..... R/o.....
- (4)..... S/o Shri..... R/o.....

all are the partners of a partnership firm namely M/S
.....(Name of firm) hereinafter referred to as 'firm', which is registered at
Registration No.....by Registrar of Firms..... The firm
is having its head office
at.....

AND WHEREAS it has come to our knowledge that NIT
No. _____ has been issued by Railtel Corporation of
India Limited for the work namely
“ _____
”

We all the above named partners on behalf of the above named firm hereby give our
consent to participate in the above tender in Joint Venture.

Further we all the above named partners on behalf of the above named firm hereby give
our consent to enter in to Joint Venture agreement, with
M/S _____ & M/S _____ (name of
other constituent(s) of joint venture) and to participate in tender as Joint Venture aforesaid.
That we/our Firm is not blacklisted or debarred by RCIL/RAILWAY or any other
Ministry / Department of Govt. of India from participation in tender on the date of opening
of bids, either in individual capacity or as a member of the partnership firm or JV in which
he was / is a partner/member. Concealment / wrong information in regard to above shall
make the contract liable for determination under Clause 62 of the General Conditions of
Contract.

Date:
Place:
Executants Partners

(Name)	(Signature)
1.....
2.
3.
4.

(seal and signature of Notary Public)

Notes: 1. In this format space has been provided for entering details of four partners and
two JV constituents however if the number vary details may accordingly be entered.

2. The document should be notarized at its place of execution (Place of signing the
document)..

3. Each page of the document should be signed by executants.

POWER-OF-ATTORNEY FOR SIGNING JOINT VENTURE AGREEMENT ON BEHALF OF PARTNERSHIP FIRM

(to be executed non judicial stamp paper of appropriate value as per law of state concerned-Non Judicial stamp paper should be purchased in the name of partners of the firm)

KNOW ALL MEN BY THESE PRESENTS: WHEREAS WE

(1)..... S/o Shri.....
R/o.....
(2)..... S/oShri..... R/o.....
(3)..... S/o Shri.....
R/o.....
(4)..... S/o Shri.....
R/o.....

All are the partners of a partnership firm namely M/s.(Name of firm) hereinafter referred to as 'firm', which is registered at Registration No.....by Registrar of Firms..... The firm is having its head office at..... (hereinafter to be referred as the 'Firm').

AND WHEREAS we all the above named partners have on.....(date) given our consent on behalf of firm to participate in the tender No. issued by RailTel Corporation of India Limited for the work namely "....." in Joint Venture with M/S.....& M/S.....

We the above named partners of above named firm do hereby irrevocably constitute, nominate, appoint and authorize Mr./ Ms. S/o Shri.....(address)..... & Mr./ Ms. S/o Shri.....(address)..... as our true and lawful attorney (hereinafter referred to as "Attorney") of the firm to jointly or severally exercise all or any of the following powers for and on behalf of M/S (name of firm) in connection with aforesaid bid:

1. To enter into and execute and sign JOINT VENTURE agreement, on behalf of our firm with M/S.....& M/S.....
2. To sign and submit all the necessary papers, letters, forms, quotes, bids etc. in connection with aforesaid bid.
3. To negotiate, discuss, agree to make any amendments, alterations or modifications thereto and to make representations, submit papers, affidavits and to do any other act and complete requisite formalities on behalf of the firm in connection with completion of aforesaid tender work and to enter into liability against the firm.
4. To sign, execute the contract with RailTel Corporation of India Limited for and on behalf of the firm.

5. And generally to do all such acts, deeds or things as may be necessary or proper for the purposes mentioned above and to enter into liability against the firm.
6. That we/our Firm is not blacklisted or debarred by RCIL/Railway or any other Ministry / Department of Govt. of India from participation in tender on the date of opening of bids, either in individual capacity or as a member of the partnership firm or JV in which he was / is a partner/member. Concealment / wrong information in regard to above shall make the contract liable for determination under Clause 62 of the General Conditions of Contract.
We on behalf of firm undertake that it shall not cancel or amend this power of Attorney without obtaining previous written consent of Railtel Corporation of India Limited.

We on behalf of firm hereby agree that all acts, deeds or things lawfully done by the said Attorneys or either of them under the authority of this power shall be construed as acts, deeds and things done by the firm and we hereby undertakes to confirm and ratify all and whatsoever the said Attorneys or either of them shall lawfully do or cause to be done by virtue of the powers hereby given.

Specimen signatures of the Attorney are appended below.

IN WITNESS WHEREOF this deed has been signed and sealed by us the under named, on this..... day of..... 20.... , in presence of:

WITNESSES:

- | | | |
|-----------------------------------|--|---|
| 1. Signature
Name:
Address: | Executants Partners
(Name)
Signature) | (|
| | 1..... | |
| | 2. | |
| | 3. | |
| | 4. | |

- | | |
|-----------------------------------|---|
| 1. Signature
Name:
Address: | Specimen Signatures of Attorney Holder(s) in token of acceptance: |
|-----------------------------------|---|

- | | |
|---------------|----------------|
| (1) Name..... | Signature..... |
| (2) Name..... | Signature..... |

Executed and Signed before me on this.....day of At(place).

(seal and signature of Notary Public)

Notes: 1. In this format space has been provided for entering details of four partners, two constituents of JV and two attorney holders, however if the number vary the details may accordingly be entered.

2. The document should be notarized at its place of execution.
3. Each page of the document should be signed by executants

AFFIDAVIT BY SOLE PROPRIETORSHIP FIRM WHEN PARTICIPATING IN JOINT VENTURE

(to be executed non judicial stamp paper of appropriate value as per law of state concerned- Non Judicial stamp paper should be purchased in the name of proprietor of the firm)

I.....S/o Shri.....aged aboutyears
R/o.....do hereby solemnly affirm and declare as under:

1. That I am running a business in the name and style of M/s..... which is a sole proprietorship firm and which has got GST registration No.....
2. That I am the sole proprietor of the said firm M/S
3. That the Head office of the above named firm is situated at.....
4. That I through my above named firm shall participate in the tender No. _____ issued by RailTel Corporation of India Limited for the work _____ namely “ _____” in Joint Venture and for the purpose shall enter into and execute joint venture agreement with M/S _____ & M/S _____ (name of other constituent(s) of joint venture).
5. That we/our Firm is not blacklisted or debarred by RCIL/ Railway or any other Ministry / Department of Govt. of India from participation in tender on the date of opening of bids, either in individual capacity or as a member of the partnership firm or JV in which he was / is a partner/member. Concealment / wrong information in regard to above shall make the contract liable for determination under Clause 62 of the General Conditions of Contract.

DEPONENT

Verification:

Verified at.....on thisday of.....that the contents of my above affidavit are true and correct to the best of my knowledge and belief and nothing material has been concealed therefrom.

DEPONENT

(seal and signature of Notary Public)

- Notes: 1. In this format space has been provided for entering details of two constituents of the JV however if the number vary details may accordingly be entered.
2. The document should be notarized at its place of execution (Place of signing the document)..
3. Each page of the document should be signed by executants.

Board's Resolution of company for entering into Joint Venture (To be printed on Company's letter head)

EXTRACT OF THE RESOLUTION PASSED AT THE MEETING OF THE BOARD OF DIRECTORS OF (Company Name) _____ (CIN _____) (hereinafter referred to as company) HELD ON (Date) _____ AT (Address) _____

Whereas the Board has been described about NIT No. _____ issued by RailTel Corporation of India Limited for the work namely " _____".

Board discussed the matter and after discussion following resolution was passed:

RESOLVED THAT the company (company name) shall participate in the above tender in Joint Venture and for the purpose the company shall enter into and execute joint venture agreement, with M/S _____ & M/S _____ (name of other constituent(s) of joint venture).

Resolved further that the Board authorizes, Mr./ Ms. _____ & Mr./ Ms. _____ (name and designation) of the company, to jointly or severally, sign joint venture agreement, and to sign such other documents and to do any other act and complete requisite formalities on behalf of the company in connection with completion of aforesaid tender work and to enter into liability against the company.

Resolved further that Board authorizes Mr./Ms. _____ (name and designation) of the company to execute Power of Attorney in terms of this resolution in favour of Mr./Ms. _____ & Mr./Ms. _____ the person(s) above named.

The acts done and documents executed by such above named authorized person(s) shall be binding on the company.

For the Organization,

(Seal of company & Signature of authorized person)

Name: _____

Designation: _____

Place:

Dated:

Executed and Signed before me on this.....day ofAt(place).

(seal and signature of Notary Public)

Notes: 1. In this format space has been provided for entering details of two constituents of the JV and two authorized persons however if the number vary details may accordingly be entered.

2. The document should be notarized at its place of execution (Place of signing the document).

3. Each page of the document should be signed by authorized signatory(s).

4. Any person / director should not be authorized to execute Power of Attorney in his own favour.



POWER-OF-ATTORNEY BY A COMPANY (incorporated under companies Act) for entering into JOINT VENTURE AGREEMENT.

(to be executed non judicial stamp paper of appropriate value as per law of state concerned- Non Judicial stamp paper should be purchased in the name of the company)

KNOW ALL MEN BY THESE PRESENTS: WHEREAS M/S
..... (name of company & CIN number) is a Company registered under the Companies Act, 2013, and having its registered office at.....
(Hereinafter called the 'Company').

AND WHEREAS by its resolution No..... passed in the meeting held on.....
of the Board of directors of the company the company (company name) has decided to participate in the tender No. _____ issued by RailTel Corporation of India Limited for the work namely " _____ "

in Joint Venture and for the purpose the company shall enter into and execute joint venture agreement with M/S _____ & M/S _____ (name of other constituent(s) of joint venture) AND THAT M/S _____ (name of the lead member of joint venture) shall act as the lead member of above mentioned joint venture.

I.....(name and designation) the authorised representative of M/S (name of company) duly authorized in this behalf by aforesaid resolution do hereby irrevocably constitute, nominate, appoint and authorize Mr./ Ms. _____ (designation) _____ (address) _____ & Mr./ Ms. Mr./ Ms. _____ (designation) _____ (address) _____ who is/are presently holding the above mentioned position in the company as our true and lawful attorney (hereinafter referred to as "Attorney") of the company to jointly or severally exercise all or any of the following powers for and on behalf of M/S (Name of company & CIN number) in connection with aforesaid bid:

1. To enter into and execute and sign JOINT VENTURE agreement, draft of which has been approved by the company, on behalf of the company with above named constituents for participating in the aforesaid bid of the Railtel Corporation of India Limited on behalf of the company.
2. To sign and submit all the necessary papers, letters, forms, quotes, bids etc.
3. To do any other act and complete requisite formalities on behalf of the company in connection with completion of aforesaid tender work and to enter into liability against the company.
4. And generally to do all such acts, deeds or things as may be necessary or proper for the purposes mentioned above.
5. That we/our (Name of the company) is not blacklisted or debarred by RCIL/Railway or any other Ministry / Department of Govt. of India from participation in tender on the date of opening of bids, either in individual capacity or as a member of the partnership firm or JV in which the company

was/is a partner/member. Concealment / wrong information in regard to above shall make the contract liable for determination under Clause 62 of the General Conditions of Contract.

The company agrees and undertakes that in the event of any change in the constitution of the company the rights and obligations of the company shall continue to be in full force without any effect thereof.

The company undertakes that it shall not cancel or amend this power of Attorney without obtaining previous written consent of Railtel Corporation of India Limited.

AND the Company hereby agrees that all acts, deeds or things lawfully done by the said Attorneys or either of them under the authority of this power shall be construed as acts, deeds and things done by the Company and the Company hereby undertakes to confirm and ratify all and whatsoever the said Attorneys or either of them shall lawfully do or cause to be done by virtue of the powers hereby given.

IN WITNESS WHEREOF this deed has been signed and sealed by Shri.....(name and designation), on this..... day of..... 20... , in presence of:

WITNESSES:

1. Signature
Name:
Address:

Executants' Signature & Seal of company:

Name:
Designation:

2. Signature
Name:
Address:

Specimen Signatures of Attorney Holder in token of acceptance:

(1) Name Signature.....

(2) Name Signature.....

Executed and Signed before me on this.....day of At(place).

(Seal and signature of Notary Public)

Notes: 1. In this format space has been provided for entering details of two constituents of the JV and two authorized persons/attorney holders however if the number vary the details may accordingly be entered.

2. The document should be notarized at its place of execution (Place of signing the document)..

3. Each page of the document should be signed by executants.

4. Executant and Power of Attorney holder should not be the same person.

POWER-OF-ATTORNEY FOR SIGNING OF BID (when Tenderer is company incorporated under companies Act)

(to be executed non judicial stamp paper of appropriate value as per law of state concerned- Non Judicial stamp paper should be purchased in the name of the company)

KNOW ALL MEN BY THESE PRESENTS: WHEREAS M/s
..... (name of company & CIN number) is a Company registered under the Companies Act, 2013, and having its registered office at..... (hereinafter called the 'Company').

AND WHEREAS by its resolution No..... passed in the meeting held on..... of the Board of directors of the company the company (company name) have decided to participate in the tender No. _____ issued by RailTel Corporation of India Limited for the work namely " _____ "

I.....(name and designation) the authorised representative of M/S (name of company) duly authorized in this behalf by aforesaid resolution do hereby irrevocably constitute, nominate, appoint and authorize Mr./ Ms. _____(designation) _____(address) & Mr./ Ms. Mr./ Ms. _____(designation) _____(address) who is/are presently holding the above mentioned position in the company as our true and lawful attorney (hereinafter referred to as "Attorney") of the company to jointly or severally exercise all or any of the following powers for and on behalf of M/S (name of company & CIN number) in connection with aforesaid bid:

1. To sign and submit Tender and participate in the aforesaid bid of the Railtel Corporation of India Limited on behalf of the company.
2. To sign and submit all the necessary papers, letters, forms, quotes, bids etc.
3. To negotiate, discuss, agree to make any amendments, alterations or modifications thereto and to make representations, submit papers, affidavits and to do any other act and complete requisite formalities on behalf of the company in connection with completion of aforesaid tender work and to enter into liability against the company.
4. To sign, execute the contract with Railtel Corporation of India Limited for and on behalf of the company.
5. And generally to do all such acts, deeds or things as may be necessary or proper for the purposes mentioned above.

The company agrees and undertakes that in the event of any change in the constitution of the company the rights and obligations of the company shall continue to be in full force without any effect thereof.

The company undertakes that it shall not cancel or amend this power of Attorney without obtaining previous written consent of Railtel Corporation of India Limited.

AND the Company hereby agrees that all acts, deeds or things lawfully done by the said Attorneys or either of them under the authority of this power shall be construed as acts, deeds and things done by the Company and the Company hereby undertakes to confirm and ratify all and whatsoever the said Attorneys or either of them shall lawfully do or cause to be done by virtue of the powers hereby given.

That our Company is not blacklisted or debarred by RCIL/Railway or any other Ministry / Department of Govt. of India from participation in tender on the date of opening of bids, either in individual capacity or as a member of the partnership firm or JV in which the Company was / is a partner/member. Concealment / wrong information in regard to above shall make the contract liable for determination under Clause 62 of the General Conditions of Contract.

IN WITNESS WHEREOF this deed has been signed and sealed by Shri.....(name and designation), on this..... day of..... 20.... , in presence of:

WITNESSES:

1. Signature
Name:
Address:

Executants' Signature & Seal of
company:
Name:
Designation:

2. Signature
Name:
Address:

Specimen Signatures of Attorney Holder(s) in token of acceptance:

(1) Name Signature.....

(2) Name..... Signature.....

Executed and Signed before me on this.....day of At
.....(place).

(seal and signature of Notary Public)

- Notes: 1. In this format space has been provided for entering details of two authorized persons/attorney holders however if the number vary details may accordingly be entered.
2. The document should be notarized at its place of execution (Place of signing the document)..
3. Each page of the document should be signed by executants.
4. Executant and Power of Attorney holder should not be the same person.

Annexure-O-10

Board's Resolution of company incorporated under companies Act for submitting Tender by company (To be printed on company's letter head)

EXTRACT OF THE RESOLUTION PASSED AT THE MEETING OF THE BOARD OF DIRECTORS OF _____ (Company Name) _____ (CIN _____) (hereinafter referred to as company) HELD ON _____ (Date) _____ AT _____ (Address)

Whereas the Board has been described about NIT No. _____ issued by Railtel Corporation of India Limited for the work namely " _____ ". Board discussed the matter and after discussion following resolution was passed:

RESOLVED THAT the company (company name) shall participate in the above tender.

Resolved further that the Board authorizes, Mr./ Ms. _____ & Mr./ Ms. _____ (name and designation) of the company, to jointly or severally sign and submit all the necessary papers, letters, forms, quotes, bids etc, negotiate, discuss, agree to make any amendments, alterations or modifications thereto and to make representations, submit papers, affidavits and to do any other act and complete requisite formalities on behalf of the company in connection with completion of aforesaid tender work and to enter into liability against the company.

Resolved further that Board authorizes Mr./Ms. _____ (name and designation) of the company to execute Power of Attorney in terms of this resolution in favour of Mr./Ms. _____ & Mr./Ms. _____ the person(s) above named.

The acts done and documents executed by such above named authorized person(s) shall be binding on the company.

For the Organization,

(Seal of company & Signature of authorized person)

Name: _____

Designation: _____

Place:

Dated:

Executed and Signed before me on this.....day of At(place).

(Seal and signature of Notary Public)

Notes: 1. In this format space has been provided for entering details of two authorized persons however if the number vary details may accordingly be entered.

2. The document should be notarized at its place of execution (Place of signing the document)..

3. Each page of the document should be signed by authorized signatory(s).

4. Any person / director should not be authorized to execute Power of Attorney in his own favour.



रेलटेल
RAILTEL

POWER-OF-ATTORNEY FOR SIGNING OF BID (when Tenderer is LLP Firm incorporated under LLP Act)

(to be executed non judicial stamp paper of appropriate value as per law of state concerned- Non Judicial stamp paper should be purchased in the name of the LLP Firm)

KNOW ALL MEN BY THESE PRESENTS: WHEREAS M/S
..... (name of LLP & LLPIN number) is a LLP Firm registered under the LLP Act, 2008, and having its registered office at..... (hereinafter called the 'LLP').

AND WHEREAS by its resolution No..... passed in the meeting held on..... of the Partners of the LLP the LLP..... (LLP name) have decided to participate in the tender No. issued by Railtel Corporation of India Limited for the work namely “

I.....name and designation) the authorised representative of M/S (name of LLP) duly authorized in this behalf by aforesaid resolution do hereby irrevocably constitute, nominate, appoint and authorize Mr./Ms. (designation) (address) & Mr./Ms./Mr./Ms. (designation) (address) who is/are presently holding the above mentioned position in the LLP as our true and lawful attorney (hereinafter referred to as “Attorney”) of the LLP to jointly or severally exercise all or any of the following powers for and on behalf of M/S (name of LLP & LLPIN number) in connection with aforesaid bid:

1. To sign and submit Tender and participate in the aforesaid bid of the Railtel Corporation of India Limited on behalf of the LLP.
2. To sign and submit all the necessary papers, letters, forms, quotes, bids etc.
3. To negotiate, discuss, agree to make any amendments, alterations or modifications thereto and to make representations, submit papers, affidavits and to do any other act and complete requisite formalities on behalf of the LLP in connection with completion of aforesaid tender work and to enter into liability against the LLP.
4. To sign, execute the contract with RCIL/Railway for and on behalf of the LLP.
5. And generally to do all such acts, deeds or things as may be necessary or proper for the purposes mentioned above.

The LLP agrees and undertakes that in the event of any change in the constitution of the LLP, the rights and obligations of the LLP shall continue to be in full force without any effect thereof.

The LLP undertakes that it shall not cancel or amend this power of Attorney without obtaining previous written consent of Railtel Corporation of India Limited.

AND the LLP hereby agrees that all acts, deeds or things lawfully done by the said Attorneys or either of them under the authority of this power shall be construed as acts, deeds and things done by the LLP and the LLP hereby undertakes to confirm and ratify all and whatsoever the said

Attorneys or either of them shall lawfully do or cause to be done by virtue of the powers hereby given.

That our LLP is not blacklisted or debarred by RCIL/Railway or any other Ministry / Department of Govt. of India from participation in tender on the date of opening of bids, either in individual capacity or as a member of JV in which the LLP was / is a member. Concealment / wrong information in regard to above shall make the contract liable for determination under Clause 62 of the General Conditions of Contract.

IN WITNESS WHEREOF this deed has been signed and sealed by Shri.....(name and designation), on this..... day of..... 20.... , in presence of:

WITNESSES:

1. Signature
Name:
Address:

Signatures of authorized representative & Seal of LLP:

Name of authorized representative(Executant):
Designation:

2. Signature
Name:
Address:

Specimen Signatures of Attorney Holder(s) in token of acceptance:

(1)Name Signature.....

(2)Name).....Signature.....

Executed and Signed before me on this.....day of At(place).

(seal and signature of Notary Public)

- Notes: 1. In this format space has been provided for entering details of two authorized persons/attorney holders however if the number vary details may accordingly be entered.
- 2. The document should be notarized at its place of execution (Place of signing the document)..
- 3. Each page of the document should be signed by executants.

Partner's Resolution of LLP Firm incorporated under LLP Act for submitting Tender by LLP firm (To be printed on Firm's letter head)

EXTRACT OF THE RESOLUTION PASSED AT THE MEETING OF THE PARTNERS OF _____ (LLP Name) having LLPIN _____ of 20..... (hereinafter referred to as LLP) HELD ON (Date) _____ AT (Address) _____

Whereas the Board has been described about NIT No. _____ issued by Railtel Corporation of India Limited for the work namely " _____". Partners discussed the matter and after discussion following resolution was passed:

RESOLVED THAT the LLP (LLP name) shall participate in the above tender.

Resolved further that the LLP/Partners authorize(s), Mr./ Ms. _____ & Mr./ Ms. _____ (name and designation) of the LLP, to jointly or severally sign and submit all the necessary papers, letters, forms, quotes, bids etc., negotiate, discuss, agree to make any amendments, alterations or modifications thereto and to make representations, submit papers, affidavits and to do any other act and complete requisite formalities on behalf of the LLP in connection with completion of aforesaid tender work and to enter into liability against the LLP.

Resolved further that LLP/Partners authorize (s) Mr./Ms. _____ (name and designation) of the LLP to execute Power of Attorney in terms of this resolution in favour of Mr./Ms. _____ & Mr./Ms. _____ the person(s) above named.

The acts done and documents executed by such above named authorized person(s) shall be binding on the LLP.

For the Organization,

(Seal of LLP & Signature of authorized person)

Name of authorized person: _____

Designation: _____

Place:

Dated:

Executed and Signed before me on this.....day of At(place).

(Seal and signature of Notary Public)

- Notes: 1. In this format space has been provided for entering details of two authorized persons however if the number vary details may accordingly be entered.
2. The document should be notarized at its place of execution (Place of signing the document).
3. Each page of the document should be signed by authorized signatory(s).

Partner's Resolution of LLP Firm for entering into Joint Venture (To be printed on LLP Firm's letter head)

EXTRACT OF THE RESOLUTION PASSED AT THE MEETING OF THE PARTNERS OF _____ (LLP Name) having LLPIN _____ of 20.....)(hereinafter referred to as LLP) HELD ON (Date) _____ AT _____ (Address)

Whereas the Partners have been described about NIT No. _____ issued by Railtel Corporation of India Limited for the _____ work namely " _____ "

. Partners discussed the matter and after discussion following resolution was passed:

RESOLVED THAT the LLP..... (LLP name) shall participate in the above tender in Joint Venture and for the purpose the LLP shall enter into and execute joint venture agreement, with M/s _____ & M/s _____ (name of other constituent(s) of joint venture).

Resolved further that the LLP/Partners authorize(s), Mr./ Ms. _____ & Mr./ Ms. _____ (name and designation) of the LLP, to jointly or severally, sign joint venture agreement, and to sign such other documents and to do any other act and complete requisite formalities on behalf of the LLP in connection with completion of aforesaid tender work and to enter into liability against the LLP.

Resolved further that _____ LLP/Partners authorize(s) Mr./Ms. _____ (name and designation) of the LLP to execute Power of Attorney in terms of this resolution in favour of Mr./Ms. _____ & Mr./Ms. _____ the person(s) above named.

The acts done and documents executed by such above named authorized person(s) shall be binding on the LLP.

For the Organization,

(Seal of LLP & Signature of authorized person)

Name of authorized person: _____

Designation: _____

Place:

Dated:

Executed and Signed before me on this.....day of At(place).

(seal and signature of Notary Public)

Notes: 1. In this format space has been provided for entering details of two constituents of the JV and two authorized persons however if the number vary details may accordingly be entered.

2. The document should be notarized at its place of execution (Place of signing the document)..

3. Each page of the document should be signed by authorized signatory(s).



रेलटेल
RAILTEL

POWER of ATTORNEY BY A LLP Firm (incorporated under LLP Act) for entering into JOINT VENTURE AGREEMENT.

(to be executed non judicial stamp paper of appropriate value as per law of state concerned- Non Judicial stamp paper should be purchased in the name of the LLP)

KNOW ALL MEN BY THESE PRESENTS: WHEREAS M/S
..... (name of LLP & LLPIN number) is a LLP
registered under the LLP Act, 2008, and having its registered office at..... (Hereinafter
called the 'LLP').

AND WHEREAS by its resolution No..... passed in the meeting held on.....
of the Partners of the LLP, the LLP..... (LLP name) has decided to
participate in the tender No. _____ issued by Railtel
Corporation of India Limited for the work namely
“ _____ ”

in Joint Venture and for the purpose the LLP shall enter into and execute joint venture agreement
with M/S _____ & M/S _____ (name of other
constituent(s) of joint venture) AND THAT M/S _____ (name of the lead
member of joint venture) shall act as the lead member of above mentioned joint venture.

I.....(name and designation) the authorised
representative of M/S (name of
LLP) duly authorized in this behalf by aforesaid resolution do hereby irrevocably constitute,
nominate, appoint and authorize Mr./ Ms.
_____(designation) _____(address) _____ & Mr./ Ms. Mr./
Ms. _____(designation) _____(address) _____ who is/are
presently holding the above mentioned position in the LLP as our true and lawful attorney
(hereinafter referred to as “Attorney”) of the LLP to jointly or severally exercise all or any of the
following powers for and on behalf of M/S
..... (Name of LLP & LLPIN number) in connection with
aforesaid bid:

1. To enter into and execute and sign JOINT VENTURE agreement, draft of which has been approved by the LLP, on behalf of the LLP with above named constituents for participating in the aforesaid bid of the Railtel Corporation of India Limited on behalf of the LLP.
2. To sign and submit all the necessary papers, letters, forms, quotes, bids etc.
3. To do any other act and complete requisite formalities on behalf of the LLP in connection with completion of aforesaid tender work and to enter into liability against the LLP.
4. And generally to do all such acts, deeds or things as may be necessary or proper for the purposes mentioned above.
5. That we/our Firm is not blacklisted or debarred by RCIL/Railway or any other Ministry / Department of Govt. of India from participation in tender on the date of opening of bids, either in individual capacity or as a member of the partnership firm or JV in which he was / is a partner/member. Concealment / wrong information in regard to above shall make the contract liable for determination under Clause 62 of the General Conditions of Contract.

The LLP agrees and undertakes that in the event of any change in the constitution of the LLP, the rights and obligations of the LLP shall continue to be in full force without any effect thereof.

The LLP undertakes that it shall not cancel or amend this power of Attorney without obtaining previous written consent of Railtel Corporation of India Limited .

AND the LLP hereby agrees that all acts, deeds or things lawfully done by the said Attorneys or either of them under the authority of this power shall be construed as acts, deeds and things done by the LLP and the LLP hereby undertakes to confirm and ratify all and whatsoever the said Attorneys or either of them shall lawfully do or cause to be done by virtue of the powers hereby given.

IN WITNESS WHEREOF this deed has been signed and sealed by Shri.....(name and designation), on this..... day of..... 20... , in presence of:

WITNESSES:

1. Signature
Name:
Address:

Signatures of authorized representative &
Seal of LLP:

Name of authorized representative:
Designation:

2. Signature
Name:
Address:

Specimen Signatures of Attorney Holder in token of acceptance:

(1)NameSignature.....

(2)NameSignature.....

Executed and Signed before me on this.....day of At
.....(place).

(Seal and signature of Notary Public)

Notes: 1. In this format space has been provided for entering details of two constituents of the JV and two authorized persons/attorney holders however if the number vary the details may accordingly be entered.

2. The document should be notarized at its place of execution (Place of signing the document).

3. Each page of the document should be signed by executants.

AFFIDAVIT BY HUF

**(to be executed non judicial stamp paper of appropriate value as per law of state concerned-
Non Judicial stamp paper should be purchased in the name of HUF**

I.....S/o Shri aged about years
R/o.....and as Karta of my Hindu
Undivided (HUF) affirm on oath and declare as under:-

1. That I am Karta of our HUF which is known as -----(HUF)
2. That as on today, name of coparceners (including name of Karta) of our above said HUF, their father name and their addresses are as under:-

S.No.	Name of Coparceners	Name of Father	Address
1.			
2.			
3.			
4.			
5.			

3. That the above said HUF is in existing since----- (Date of incorporation of HUF).
4. That I, in the position of KARTA of Hindu Undivided (HUF) am submitting the tender on behalf of HUF and declare that the acts done and documents executed by me shall be binding on the HUF, M/s-----
5. That I/HUF Firm is not blacklisted or debarred by RCIL/Railway or any other Ministry / Department of Govt. of India from participation in tender on the date of opening of bids, either in individual capacity or as a member of the partnership firm or JV in which he was / is a partner/member. Concealment / wrong information in regard to above shall make the contract liable for determination under Clause 62 of the General Conditions of Contract.

DEPONENT

Verification:

Verified at.....on thisday of.....that the contents of my above affidavit are true and correct to the best of my knowledge and belief and nothing material has been concealed therefrom.

DEPONENT

Karta of HUF-M/s-----

(seal and signature of Notary Public)

- Notes: 1. The document should be notarized at its place of execution (Place of signing the document).
2. Each page of the document should be signed by executants.

Annexure-P-1

Request letter from Executive branch to Accounts Office for opening of LC

Office of.....

No. _____

Dated _____

The
HQ/Division/Workshop/ Cost.

PFA/Sr.DFM/Dy.FA

Sub: Opening of LC

Ref: Supply Order/Contract Agreement No.

It is requested to open a sight LC against the above referred Order/Agreement in favour of _____ . The details of beneficiary are as under:

- (i) Name of Contractor/Supplier
- (ii) Vender Code
- (iii) Address
- (iv) Tender No.
- (v) Contract Agreement No.
- (vi) Description of Goods/Service
- (vii) Value of Contract
- (viii) Stages of payment
- (ix) Expected payment within 6 months (LC Amount)
- (x) Beneficiary bank details
 - a) Bank name
 - b) Address
 - c) Account No.
 - d) IFSC code
- (xi) Validity/Period for which LC is to be opened:

It is certified that the supplier/contractor has exercised the option of taking payment due against the tender, through LC arrangement in IREPS portal at the time of bidding itself and the option has been flagged in the IREPS. This has the approval of _____.

(Signature)

Name _____

Designation _____

(Official Seal)

LCDA No. (18 DIGIT IPAS GENERATED NO.)

Dated: _____

DOCUMENT OF AUTHORIZATION

Reference : (i) Works Contract/supply Contract No. _____ Dated _____

(ii) Inland Letter of Credit No. _____ Dated _____

This document is issued against contract No.....(FROM IREPS) ----- Dated-----for supply/work of..... (DESCRIPTION OF GOODS/WORKS FROM IREPS) -----

The beneficiary of the aforementioned Letter of Credit M/s..... (NAME AND VENDOR CODE)..... (Vender Code..... as per IRPES.....) is entitled to receive payment aggregating INR----\$\$\$----- (FROM ABSTRACT OF BILL PASSED). Out of a total LC amount of INR..... (FROM MASTER TABLE OF LC OPENED)..... Against the first/second* commercial Invoice No. (FROM IPAS) _____ dated _____ FROM IPAS _____ for INR (FROM IPAS ----- raised against the above contract from State Bank of India----- (branch- FROM LC MASTER TABLE)----- on the strength of this Certificate.

The details of payments already made to the beneficiary under this Letter of Credit are as follows:

S.No.	Invoice No.	Invoice Date	Invoice Amount(INR)	LCDA No.	LCDA date	Amount paid (INR)
Total Paid						

THE PAYMENT: -INR _____ \$\$\$ _____

LC BALANCE AFTER THIS PAYMENT: _____ -

(Signature of authorised RCIL authority)
Name

Designation

Official Seal

ANNEXURE-Q

DECLARATION/UNDERTAKING

I/We(Name and Designation of tenderer/Authorized Person of tender) do hereby declare as under :

1. That I/We are an individual/ Partnership firm/Company/ Society/JV and :
 - (a) That I/We are not a retired Engineer of the gazetted rank or any other gazetted officer working before retirement, whether in the executive or administrative capacity or whether holding a pensionable post or not, in the Engineering or any other department of any of the RCIL/Railway owned and administered by the President of India for the time being,
 - (b) That I/We being partnership firm / company / joint venture (JV) / registered society / registered trust etc have none of our partners a retired Engineer or retired gazetted officer as aforesaid.
 - (c) That I/We being an incorporated company have not any such retired Engineer or retired officer as one of directors.
 - (d) That I/We do not have in our employment any retired Engineer or retired gazetted officer retired from government service (at least 1 year prior to the date of submission of the tender)
 - (e) That I/We being an individual contractors, do not have a Member (s) of or in the case of partnership firm/ company / joint venture (jv) / registered society / registered trust etc. have one or more of partner(s) /shareholder(s) or member(s) of of the partner(s) /shareholder(s) employed in gazetted capacity in the Engineering or any other department of the Railway.

OR

- 2 (a) That I am a Retired Engineer of the Gazetted rank participated in the tender in individual capacity as (Name of the firm) with following details :

Name	Date of retirement	Post held, Place and Railway unit from which retired	Details of permission taken if such retired Engineer or Gazetted Officer had not retired from Govt. Office at least 1 year prior to the date of submission of tender

- 2 (b) That I/We are a Partnership firm/Company/Society/JV and have following retired Railway Gazetted Officer as our Partner(s)/ Director(s)/Employee :

S. No.	Name	Position in tendering entity i.e. Partner/Director Employee	Date of Retirement, Post held, Place and Railway unit from which retired	Details of permission taken if such Retired Engineer or Gazetted Officer had not retired from Govt. Office at least 1 year prior to the date of submission of tender

- 2 (c) That I/We are an Individual/Partnership firm/Company/Registered Society/Trust/JV and have following partner(s) /Share Holder(s) not having share of more than 1% or member(s) of of the individual tenders/ partner(s) /Share Holder(s) employed in Gazetted capacity in the Indian Railway :

S. No.	Name of the gazetted Railway Officer who is/are partner(s) /Share Holder(s) or member(s) of of Share Holder(s) of tenderer	Post held and Place of Posting	/ Unit	Details of Share holding or Relationship with individual/ share holder of the tenderer

Note :

- (i) **Strike Off (1) or (2) as applicable.**
(ii) **In case (1) is applicable and any of the 2(a), (b) or (c) is not applicable NIL may be filled.**

Place:- (Signatures of Authorized signatory)

Name of the tendering firm

Dated:



**STANDARD AGREEMENT
(For EBR-IF Funded Contracts Only)**

Articles of agreement made on this day -----in the year Two Thousand and Twenty between the President of India, acting through the -----<RCIL> Administration having its office at -----hereinafter called the RCIL of the first part and < -----Name of Contractor----> hereinafter called the 'Contractor' of the second part and Indian Railway Finance Corporation Limited hereinafter called the 'IRF' of the third part having its office at -----with GSTIN----- <GSTIN of billing unit (IRFC)>.

First part, second part and third part collectively hereinafter called the 'Parties'.

Whereas the party hereto of the second part executed an agreement with the party hereto of the first part being agreement no. -----dated-----with contract cost of Rs.----- for performance of -----hereinafter called the 'Principal Agreement'.

Now it is hereby agreed by and between the parties that Indian Railway finance Corporation shall be made an additional party to the Principal agreement executed between RCIL and Contractor with effect from date of this agreement.

It is agreed by and between the parties that RCIL shall continue to be held responsible for all obligations, risk and liabilities, whatsoever, arising out of or in connection with the Principal Agreement and this Agreement, whether during the progress of the work or after its completion.

It is further agreed and understood by and between the parties that IRFC shall be the owner of assets, if any, arising out of execution of works as defined in the Principal Agreement, except the land whose ownership shall continue with RCIL. Accordingly, the invoices shall be issued by capturing GSTIN of contractor (as the supplier) and GSTIN of IRFC (as the bill to party). Also, the contractor shall submit the invoice, issued in the name of IRFC, to RCIL for processing payment by RCIL to Contractor subject to applicable TDS under the Income Tax, GST or any other applicable laws.

It is further agreed by and between the parties that IRFC shall be responsible to comply with Income Tax and GST laws in relation to filing of returns.

It is further agreed and understood by and between the parties that, except for the amended obligations as mentioned above, the terms of the Principal Agreement for all kind of contractual/performance and legal obligations shall remain in full force and effect.

All the communication in relation to the Principal agreement and said Agreement, would only be between party hereto of first part and Second part.

For and on behalf of the President of India

Witness of the Signature

1. -----
2. -----

Address: -----

For and on behalf of the Indian Railway Finance Corporation

Witness of the Signature

1. -----

2. -----

Address: -----

Signature of contractor

<Name of authorised signatory>

Witness of the Signature

1. -----

2. -----

Address: -----



FORMAT FOR CERTIFICATE TO BE UPLOADED BY TENDERER ALONGWITH THE TENDER DOCUMENTS

I/we..... (*Name and designation*)** appointed as the attorney/authorised signatory of the tenderer (including its constituents), have read the clause regarding restrictions on procurement from a bidder of a country which shares a land border with India; I/we including any of its constituent certify that this bidder is not from such a country or, if from such a country, has been registered with the Competent Authority (Appropriately modify the wording as per applicability) .

I/we including any of its constituent further certify that this bidder will not sub-contract any work to a contractor from such countries unless such contractor is registered with the Competent Authority.

I/we including any of its constituent hereby certify that this bidder fulfils all requirements in this regard and is eligible to be considered.

[Where applicable, evidence of valid registration by the Competent Authority shall be attached.]

Signature of the tenderer

Place:

Dated:

**The contents in Italics are only for guidance purpose. Details as appropriate, are to be filled in suitably by tenderer.



Instructions for Bid Security Declaration to be uploaded on IREPS by Tenderer alongwith the Tender Documents

DELETED (NOT APPLICABLE)



रेलटेल
RAILTEL

Format for Integrity Pact

RailTel Corporation of India Limited, herein after referred to as "The Principal".

And

.....,herein after referred to as "The Bidder/Contractor"

Preamble

The Principal in tends to award, under laid down organizational procedures, contract/s for The Principal values full compliance withal relevant laws of the land, rules, regulations, economic use of resources and of fairness/transparency in its relations with its Bidder(s) and/or Contractor(s).

In order to achieve these goals, the Principal will appoint an Independent External Monitor (IEM), who will monitor the tender process and the execution of the contract for compliance with the principles mentioned above.

Section 1-Commitments of the Principal

1. The Principal commits itself to take all measures necessary to prevent corruption and to observe the following principles:-
 - a. No employee of the Principal, personally or through family members, will in connection with the tender for, or the execution of a contract, demand, take a promise for or accept, for self or third person, any material or immaterial benefit which the person is not legally entitled to.
 - b. The Principal will during the tender process treat all Bidder(s) with equity and reason. The Principal will in particular, before and during the tender process, provide to all Bidder(s) the same information and will not provide to any Bidder(s) confidential/additional information through which the Bidder(s) could obtain an advantage in relation to the process or the contract execution.
 - c. The Principal will exclude from the process all known prejudiced persons.
2. If the Principal obtains information on the conduct of any of its employees which is a criminal offence under the IPC/PC Act, or if there be a substantive suspicion in this regard, the Principal will inform the Chief Vigilance Officer and in addition can initiate disciplinary actions.

Section 2-Commitments of the Bidder(s)/Contractor(s)

- 1 The Bidder(s)/Contractor(s) commit himself to take all measures necessary to prevent corruption. He commits himself to observe the following principles during his participation in the tender process and during the contract execution.
 - a. The Bidder(s)/contractor(s) will not, directly or through any other persons or firm, offer promise or give to any of the Principal's employees involved in the tender process or the execution of the contract to any third person any material or other benefit which he/she is not legally entitled to, in order to obtain in exchange any advantage during tender process or during the execution of the contract.

- b. The Bidder(s)/Contractor(s) will not enter with other Bidders into any undisclosed degree of understanding, whether formal or informal. This applies in particular to prices, specifications, certifications, subsidiary contracts, submission or non-submission of bids or any other actions to restrict competitiveness or to introduce cartelization in the bidding process.
- c. The Bidder(s)/Contractor(s) will not commit any offence under the relevant IPC/PC Act; further the Bidder(s)/Contractors will not use improperly, for purposes of competition or personal gain, or pass on to others, any information or document provided by the Principal as part of the business relationship, regarding plans, technical proposals and business details, including information contained or transmitted electronically.
- d. The Bidder(s)/Contractor(s) of foreign origin shall disclose the name and address of the Agents/representatives in India, if any. Similarly, the bidder(s)/contractor(s) of Indian Nationality shall furnish the name and address of the foreign principals, if any. Further details as mentioned in the "Guidelines on Indian Agents of Foreign Suppliers" shall be disclosed by the Bidder(s)/Contractor(s). Further, as mentioned in the Guidelines all the payments made to the Indian agent/representative have to be in Indian Rupees only. Copy of the "Guidelines on Indian Agents of Foreign Suppliers" as annexed and marked as Annexure A.
- e. The Bidder(s)/Contractor(s) will, when presenting his bid, disclose any and all payment she has made, is committed to or intends to make to agents, brokers or any other intermediaries in connection with the award of the contract.

2. The Bidder(s)/Contractor(s) will not instigate third persons to commit offences outlined above or be an accessory to such offences.

Section 3: Dis-qualification from tender process and exclusion from future contracts

If the Bidder(s)/Contractor(s), before award or during execution has committed a transgression through a violation of Section 2, above or in any other form such as to put his reliability or credibility in question, the Principal is entitled to disqualify the Bidder(s)/Contractor(s) from the tender process **& exclude him from future business dealings as per the existing provisions of GFR, 2017, PC ACT 1988** or take action as per the procedure mentioned in the "Guidelines on Banning of business dealings" and **any other Financial Rules/Guidelines applicable to the Principal**. Copy of the "Guidelines on Banning of business dealings" is annexed and marked as Annex-"B".

Section 4: Compensation for Damages

1. If the Principal has disqualified the Bidder(s) from the tender process prior to the award according to Section 3, the Principal is entitled to demand and recover the damages equivalent to Earnest Money Deposit/Bid Security.
2. If the Principal has terminated the contract according to Section 3, or if the Principal is entitled to be terminated the contract according to Section 3, the Principal shall be entitled to demand and recover from the Contractor liquidated damages of the Contract value or the amount equivalent to Performance Bank Guarantee.

Section 5: Previous Transgression

1. The Bidder declares that no previous transgressions occurred in the last three years with any other company in any country conforming to the anti corruption approach or with any other public sector enterprise in India that could justify his exclusion from the

- tender process.
2. If the bidder makes incorrect statement on this subject, he can be disqualified from the tender process for action can be taken as per the procedure mentioned in "Guidelines on Banning of business dealings".

Section 6: Equal treatment of all Bidders/Contractors/Subcontractors.

1. The Bidder(s)/Contractor(s) undertake(s) to demand from all sub contractors assigned commitment in conformity with this Integrity Pact, and to submit it to the Principal before contract signing.
2. The Principal Contractor shall take the responsibility of the adoption of IP by the sub-contractors. It is to be ensured that all sub-contractors also sign the IP.
3. **In case of a Joint Venture, all the partners of the Joint Venture should sign the Integrity pact.**
4. The Principal will disqualify from the tender process all bidders who do not sign this Pact or violate its provisions

Section 7: Criminal charges against violation by Bidder(s)/Contractor(s)/Subcontractor(s)

If the Principal obtains knowledge of conduct of a Bidder, Contractor or Sub contractor, or of an employee or a representative or an associate of a Bidder, Contractor or Subcontractor which constitutes corruption, or if the Principal has substantive suspicion in this regard, the Principal will inform the same to the Chief Vigilance Officer.

Section 8: Independent External Monitor /Monitors

1. The Principal appoints competent & credible Independent External Monitors for this pact as nominated by the Central Vigilance Commission (CVC) Government of India, from the panel of IEMs maintained by it. The task of the Monitors is to review independently and objectively, whether and to what extent the parties comply with the obligations under this agreement.
2. The Monitor is not subject to instructions by the representatives of the parties and performs his functions neutrally and independently. He reports to the CMD, RailTel.
3. The Bidder(s)/Contractor(s) accepts that the Monitor has the right to access without restriction to all project documentation of the Principal including that provided by the Contractor.
4. The Contractor will also grant the Monitor, upon his request and demonstration of a valid interest, unrestricted and unconditional access to his project documentation. The same is applicable to Subcontractors. The Monitor is under contractual obligation to treat the information and documents of the Bidder(s)/Contractor(s)/Subcontractor(s) with confidentiality.
5. The Principal will provide to the Monitor sufficient information about all meetings among the parties related to the Project provided such meetings could have an impact on the contractual relations between the Principal and the Contractor. The parties offer to the Monitor the option to participate in such meetings.
Note: However, the documents/records/information having National Security implications and those documents which have been classified as Secret/Top Secret are not to be disclosed.
6. **For ensuring the desired transparency and objectivity in dealing with the complaints arising out of any tendering process or during execution of contract, the matter should be examined by the full panel of IEMs jointly, who would look into the records, conduct an investigation, and submit their joint recommendations to the Management.** Beyond this, the Monitor has no right to demand from the parties that they act in a specific manner, refrain from action or tolerate action.

The advice of the IEM panel is restricted to resolving issues raised by a bidder regarding any aspect of the tender which allegedly restricts competition or bias towards some bidders.

7. **The panel of IEMs are expected to** submit a **joint** written report to the CMD, RailTel-**within 30 days** from the date of reference or intimation to him by the Principal and, should the occasion arise, submit proposals for correcting problematic situations.
8. Monitor shall be entitled to compensation on the same terms as being extended to /provided to Independent Directors on the RailTel Board.
9. The IEMs would examine all complaints received by the mand give their recommendations / views to the CMD, RailTel at the earliest. They may also send their report directly to the CVO in case of suspicion of serious irregularities requiring legal /administrative action. Only in case of very serious issue having a specific, verifiable vigilance angle, the matter should be reported directly to the Chief Vigilance Commission.
10. The word 'Monitor' would include both singular and plural.
11. In the event of any dispute between the management and the contractor relating to those contracts where Integrity Pact is applicable, in case, both the parties are agreeable, they may try to settle dispute through mediation before the panel of IEMs in a time bound manner. If required, the organizations may adopt any mediation rules for this purpose. In case, the dispute remains unresolved even after mediation by the panel of IEMs, the organization may take further action as per the terms & conditions of the contract. However, not more than five meetings shall be held for a particular dispute resolution. The fees/expenses on dispute resolution shall be equally shared by both the parties.

Section 9: Pact Duration

Integrity Pact, in respect of a particular contract, shall be operative from the date IP is signed by both the parties till the completion of contract. After award of work, the IEMs shall look into any issue relating to execution of contract, if specifically raised before them. However, the IEMs may suggest systemic improvements to the management of the organization concerned, if considered necessary, to bring about transparency, equity and fairness in the system of procurement.

In case BIDDER is unsuccessful, this Integrity Pact shall expire after six months from the contract has been awarded.

If any claim is made / lodged by either party during this time, the same shall be binding and continue to be valid despite the lapse of this pact as specified above, unless it is discharged /determined by CMD of RailTel.

Section 10: Other Provisions

1. This agreement is subject to Indian Law, Place of performance and jurisdiction is the Registered Office of the Principal, i.e. New Delhi.
2. Changes and supplements as well as termination notices need to be made in writing.
3. If the Contractor is a partnership or a consortium, this agreement must be signed by all partners or consortium members.
4. Should one or several provisions of this agreement turn out to be invalid, the remainder of this agreement remains valid. In this case, the parties will strive to come to an agreement to their original intentions.
5. The parties signing the IP shall not approach the Courts while representing the matters to the IEMs and he/she will await the decision in the matter.
6. Principal contractor shall take the responsibility of the adoption of IP by the sub-contractor

7. The Integrity pact shall be deemed to form apart of contract and parties shall be bound by its provision.

8. Issues like warranty/guarantee etc. should be outside the purview of IEMs.

(For & on behalf of the Principal)
(Office Seal)
Place _____
Date _____

(For & On behalf of Bidder/Contractor)
(Office Seal)

Witness 1:
(Name & Address)

Witness 2:
(Name & Address)

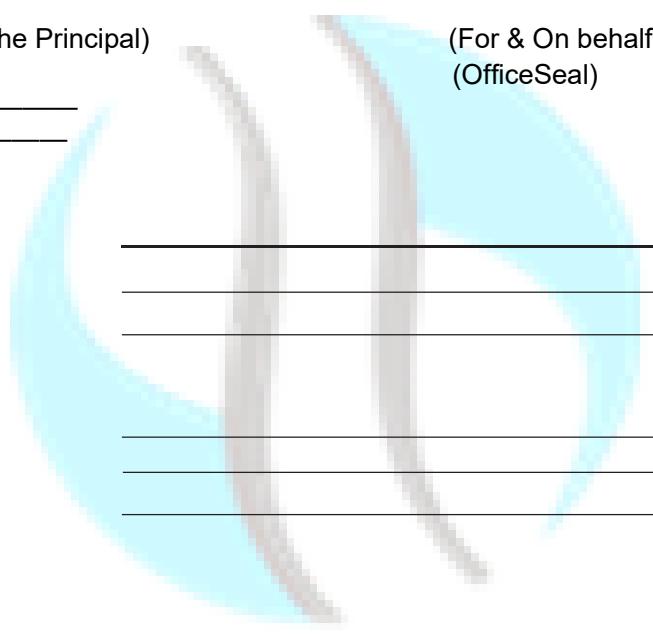

रेलटेल
RAILTEL

EXTENSION OF PERIOD OF COMPLETION OF WORK

No. Date:

To

.....

.....

Sub: (i) Name of Work

(ii) Acceptance Letter No.

(iii) Agreement No.

Ref:(Quote specific application of the Contractor for extension to date, if received).

Dear Sir,

The stipulated date for completion of the work mentioned above is From the progress made so far and the present rate of progress, it is unlikely that the work will be completed by the above date (or) However, the work was not completed on this date.

Expecting that you may be able to complete the work if some time is given by that Executive Director/N.Region, RailTel Corporation of India Limited, New Delhi, although not bound to do so, hereby extends the time for completion from to.....

* In consideration of the circumstances explained in your letter of request RailTel has extended the completion period by Days without any liquidated damages. Please ensure the completion and commissioning of the project well within the extended period.

* Please note that an amount equal to 0.5 % of the total value of the contract per week or part thereof (rounded off to the nearest whole number) subject to a maximum of 10% of the total contract value of the works as a recovery for delay in the completion of the work after the expiry of (1) will be recovered from as mentioned in clause 22.2 of vol.-I of the special conditions of contract for the extended period notwithstanding the grant of this extension. You may proceed with the work accordingly.

The above extension of the completion date will also be subject to the further condition that no increase in rates on any account will be payable to you.

Please intimate within a week of the receipt of this letter your acceptance of the extension on the conditions stated above.

Please note that in the event of declining to accept the extension on the above said conditions or, in the event of your failure after accepting or acting up to this extension to complete the work by (2) (here mention the extended date), further action will be taken in terms of relevant clause of special conditions of contract.

Yours faithfully,

for & on behalf of RailTel Corporation of India Limited

Note:

(1) Give here the stipulated date for completion without any penalty fixed earlier.

(2) Here mention the extended date.

*Strike out one of the clauses as applicable.

ANNEXURE-AA

SYSTEM PERFORMANCE GUARANTEE

PROFORMA FOR THE SYSTEM PERFORMANCE GUARANTEE

To

The Executive Director / RP,

RailTel Corporation of India Limited

I/we _____ hereby guarantee that the design on the basis of which we have submitted out tender No. _____ has been carefully made to confirm to the end objectives in the tender documents and to technical specifications therein. We further guarantee that in the event of the performance of the system, when installed, not complying with the end objectives or with the specifications contained in the tender documents, we shall provide further inputs to enable the RCIL to realize the end objectives contained in these documents without any additional payment for any additional equipment which may be required in this regard. We further guarantee that all the expenses including the expenses incurred in India/abroad for providing the additional inputs under the System Guarantee will be borne by us. We further guarantee that these additional inputs will be provided by us to make the system workable within 36 months from the date on which this guarantee is invoked by the Purchaser.

(Signature of Firm's authorized Officer)

Seal

Signature

of

witness:

1.-----

2.-----

ANNEXURE-AB

STATEMENT OF DEVIATIONS

PROFORMA FOR STATEMENT OF DEVIATIONS

1.0 The following are the particulars of deviations from the requirements of the instructions to TENDERERS, General Conditions of Contract.

1.1 Instructions to Tenderers.

Clause Deviation Remarks (Including Justification)

1.2 General Conditions of Contract.

Clause Deviation Remarks (Including Justification)

1.3 Special Conditions of Contract

Clause Deviation Remarks (Including Justification)

2.0 The following are the particulars of deviations from the requirements of the technical specifications:

(Separate Statement for each specification)

Clause Deviation Remarks (Including Justification)

NOTE:

Where there is no deviation, the statement should be returned duly signed with an endorsement indicating no deviations.

Signatures of tenderer/s

रेलटेल
RAILTEL

ANNEXURE-AC

CERTIFICATE

Joint Inspection of Cable trench & protective works

(FOR TELECOM WORKS)

1. The cable trench/channel including ducts, pipes & arrangements etc. en-route has been jointly inspected by us on the following sections and the work has been done according to the specifications. The laying of cable can be taken on these sections after the deficiencies noted below are rectified and offered for further check.

2. S.No. From KM To KM Remarks/deficiencies if any

3. The following joints have been supervised and provided as per manufacturer's instructions and it is confirmed that all the material or kits have been used up.

- S.No. Type of joint Locations (K M. No.) Remarks/Deficiency if any

Signature of Contractor's

Representative with

Designation

Signature of Purchaser's

Representative with

Designation



ANNEXURE-AD

STANDARD INDEMNITY BOND FOR ON ACCOUNT PAYMENT

We M/s. _____ hereby Undertake that we held in our custody for and on behalf of the President of India Acting in the Premises through the ED/RP., New Delhi hereinafter referred to as the "Purchaser" and as has property in trust for him all imported and indigenous materials which have been handed over to us against the contract for the works in the section.

_____ To _____ Stations on RCIL/Railway vide letter for acceptance of Tender No. _____ date _____ and materials such as _____ handed over to us by the purchaser for the purpose of execution of the said contract, until such time the materials are duly erected or otherwise handed over to him. We shall be entirely responsible for the same custody and protection of the said materials against all risk till they are duly delivered as erected equipment to the purchaser, or as he may direct otherwise and shall indemnify the purchaser against any loss or damaged deterioration whatsoever in receipt of the said materials while in our possession and against disposal or surplus materials. The said materials shall at all times be open to inspection by any officer authorized by the ED/RP, New Delhi or his successor.

Should any loss, damage or deterioration of materials, occur or surplus materials disposed off and refund becomes due, the purchaser shall be entitled to recover from us the full cost and compensation determined in terms of the contract for such loss or damage if any, along with the amount to be refunded without prejudice to any other remedies available to him by deduction from any sum due or any sum.

Date _____ day of _____ (month & year).

Signature of witness

Name of witness in Block letters.

Address

For and on behalf of

M/s. _____

(Contractor).

ANNEXURE-AE
GUARANTEE BOND

1. Consideration of the President of India (hereinafter called “the Government”) having agreed to exempt M/s. _____ (hereinafter called “the said contractor(s)”) from the demand for the payment of security deposit for the due fulfillment by the/said contractor(s) on the terms and conditions of the Agreement No. _____ dated _____ made between _____ and _____ for (hereinafter called “the said Agreement”) on production of a bank guarantee for Rs. _____ (Rs. _____ only). We _____ Bank Ltd., (hereinafter referred to as “the Bank” do hereby undertake (and promise) to pay the Government an amount not exceeding Rs. _____ against any loss or damage caused to or suffered by the Government by reason of any breach by the said contractor(s) of any of the terms of conditions contained in the said Agreement.

2. We _____ Bank Ltd. Further agree and promise) to pay the amounts due and payable under this guarantee without demur, merely on demand from the Government through the ED/RP, Delhi stating that the amount claimed is due by way of loss or damage caused to or would be caused to or suffered by the Government by reason of any breach by the said contractor(s) of any of the terms & conditions contained in the said agreement or by reason of the contractor(s) failure to perform the said Agreement. Any such demand made on the Bank shall be conclusive as regards the amount due and payable by the Bank under this guarantee. However, our liability under guarantee shall be restricted to an amount not exceeding Rs. _____.

3. We _____ Bank Ltd., further agree that the guarantee herein contained shall remain in full force and effect during the period that would be taken for the performance of the said agreement and that it shall continue to be enforceable till all the dues of the Government under or by virtue of the said Agreement have been fully paid and its claims satisfied or discharged or till _____ (office/deptt.). Ministry of _____ certifies that the terms and conditions of the said Agreement have been fully and properly carried out by the said contractor(s) and accordingly discharges the guarantee. Unless a demand or claim under this guarantee is made on us in writing on or before (2 months after the date of completion of the contract) we shall be discharged from all liability under this guarantee thereafter.

(a) Notwithstanding anything to the contrary contained herein the liability of the Bank under this guarantee will remain in force and effect until such time as this guarantee is discharged in writing by the Government of until _____ (the date of the expiry of the contract) whichever is earlier and no claim shall be valid under this guarantee unless notice in writing thereof is given by the Government within 2 months from the date aforesaid).

(b) (Provided that we _____ Bank unconditionally undertakes to renew this guarantee or to extend the period of guarantee from year to year within two months before the expiry of the period or the extended period of the guarantee, as the case may be, on being called upon to do so by the Government. If the guarantee is not renewed or the period extended on demand, we _____ Bank shall pay the Government the full amount of the Guarantee on demand and without demur.

3. We, _____ Bank Ltd., further agree with the Government that the Government shall have the fullest liberty without our consent and without effecting in any manner out of obligations hereunder to vary any of the terms and conditions of the said contractor (s) from time to time or to postpone for any time or from time to time any of the powers exercisable by the Government against the said contractor(s) and to forebear or enforce any of the terms and conditions of the said agreement and we shall not be relieved from our liability by reason of any such variation, or extension being granted to the said contractor(s) or for any bearance, act or Omission on the part of the

Government or by any indulgence by the Government to the said contractor(s) or by any such matter or thing whatsoever which under the law relating to sureties but for the said reservation would relieve us from the liability.

5. This guarantee will not be revoked by any change in the constitution of the Bank and or of the surety.

6. We, _____ Bank Ltd.,
lastly undertake not to revoke this guarantee during its currency except with the previous consent of the Government in writing.

Dated _____ day _____



रेलटेल
RAILTEL

Annexure-AF

ACKNOWLEDGMENT FOR RECEIVING MATERIALS FROM RCIL.

To,

Station:

The ED / RP
RailTel Corporation of India Limited
Delhi

Date:

Sir,

SUB: Receipt of materials/Cables from RCIL

It is hereby acknowledged that the following materials/cables as detailed have been received in full and in good condition by me at _____ No. _____ and the work coming under the agreement No. _____ Dated _____.

Sr. No.	Description of materials	Qty./Nos.	Remarks if any
1.			
2.			
3.			

Signature of Engineer's
Representative with
designation



Signature of Contractor.

Witnessed By:

**Special Condition as per N. Rly CE Circulars
(Supply of Cement and Steel)**

1	Ordinary Portland Cement grade 43 confirming to IS-8112-1989 will be arranged by the contractor at his own cost.
2	Supply for cement by contractor will be governed by the following conditions.
2.1	Cement for use in works, shall be procured by the contractor from the main producers or their authorized dealers only .
2.2	Cement older than 3 months from the date of manufacture as marked on the bags shall not be accepted. Cement bags should bear the following marking :-
2.2.1	Manufacturers name
2.2.2	Regd. trade mark of manufacturer if any.
2.2.3	Type of cement
2.2.4	Weight of each bag in kg or no. of bags/tones.
2.2.5	Date of manufacture generally marked as week of the year/year of manufacture.
2.3	Quality test certificate for cement as per IS 4031 shall be furnished by the contractor/s at his own cost from the mfg. Before used of cement.
2.4	RCIL may also take sample during the course of execution of work and get the cement tested to ascertain its conformity to the relevant IS specifications at contractors cost before a particular lot is put to use. Frequency of testing shall be as prescribed by the relevant IS code. Following test interlaid shall be carried out
2.4.1	Fineness.
2.4.2	Compressive strength
2.4.3	Initial and final setting time
2.4.4	Consistency
2.4.5	Soundness.
2.5	In case samples tested do not pass quality tests conducted, the entire batch of cement supplied shall be rejected and returned to the contractor/s no payment will be made on this account
2.6	For storage of cement, the contractor shall have to construct temporary Godown at his own cost. The contractor shall bring the cement to the site of work only on written instructions from in-charge of work.
2.7	The record of cement brought to the site of work, daily consumption, daily opening balance and closing balance shall be maintained at the site jointly by the RCIL Representative and contractor/s or his/their authorized representative. For this purpose, 2 sets of registers duly reconciled and signed by the RCIL Repetitive of work certifying the opening balance,. Consumption, closing balance should be maintained. One register each shall be kept in the custody of in-charge of work of RCIL and contractor or his authorized representative.
2.8	The contractor shall be the custodian of cement Godown and shall keep the Godown under his lock and key to ensure safe custody of cement. The contractor shall ensure that the cement once brought to the site and accounted shall be used at the site only and shall not be taken from site for any purpose.
2.9	The contractor shall make the cement Godown available for inspection any time along with connected record to the site Engineer or his representative as and when required.

2.10	Land for constructing the temporary cement Godown shall be handed over by the Railway on the written request of the contractor free of any rent, for construction period only.
2.11	The contractor shall ensure that after completion of the work and /or termination of the cement for any reason whatsoever, the temporary cement Godown shall be dismantled and all dismantled material/debris shall be removed and the clear site shall be handed over back to Railways. All the released material shall be the property of the contractor/s and no payment shall be made by the Railway's for dismantling leading the material etc. The final bill and earnest money shall not be released unless the Godown is dismantled and the site is cleared in all respects.
3.0	Tolerance requirements for the mass of cement.
3.1	Cement supplied one time will be taken as forming one batch. The number of bags taken for sample from each batch shall be as under:- [(S.No.)(Batch Size)(Sample size)]-[(a)-(100- 150)-(20)]-[(b)-(151-280)-(32)]-[(c)-(281-500)- (50)]-[(d)-(501-1200)-(80)]-[(e)-(1201-3200)-(125)]-[(f)-(3201 and above)- (200)]
3.2	The number of bags in sample showing a minus error greater than 2 percent of the specified net mass (50kg) shall be not more than 5 percent of bags in the sample. Also the minus error in one of such bags in the sample shall exceed 4 percent of the specified net mass of cement in the bags. In case, the minus error exceeds the percentages herein, the entire batch of cement samples shall be rejected
3.3	In case of designed mix of concrete of specified strength where the cement is to be used by weight where specifically ordered in the NS item rate or tender conditions, a variation of +1% (max) will be allowed in the consumption of cement of works.
3.4	Stacking of cement in the Godown shall be done on a layer of wooden sleepers so as to avoid contact of cement bags with the floor, or alternatively scrap of sheets may be used in place of sleepers but these must be placed at least 20cm above the floor. The bags shall be stacked at least 50cm clear of the walls to prevent deterioration. The wooden sleepers/scrap GI sheet shall be arranged by the contractor/s at his /their own cost.
3.5	Cement shall be stored in such a manner as to permit easy access for proper inspection. Cement should be stacked not more than ten layers high to prevent bursting of bags in the bottom layers and formation of clods. The stacks of cement bags shall be covered with tarpaulin during monsoons so as to obviate the possibility of deterioration of cement by moisture in the atmosphere. Cement that is set or partially set is on no account to be used.
3.6	When Portland pozolana cement is used in plain & reinforcement concrete, it is to be ensured that proper curing of concrete at least for 14 days and supporting form work shall be removed till concrete attains at least 75% of the design strength
5.0	Supply of steel: The reinforcement steel for RCIL projects/ contracts is to be procured from approved primary producers having integrated steel plants namely SAIL, TISCO, RINL, JINDAL and other firms as per approved list of RDSO on the date of supply of steel or their authorized dealers/authorized stock yard which should conform to latest relevant BIS specification. In case of RDSO approved firms, contractor has to submit proof of approved firm.(NR HQ letter No. DOE/PRODUCT APPROVAL CIVIL ENGG. (L)/2016-17 DATED 21.11.2016



VOLUME –II
GENERAL CONDITION OF CONTRACT

रेलटेल
RAILTEL

GENERAL CONDITIONS OF CONTRACT

1. Definitions
2. General Obligations
3. Law governing the Contract
4. Communications to be in writing
5. Service of Notices on Contractors
6. Occupations and use of land
7. Assignment or subletting of contract
8. Assistance by the RailTel for the stores be obtained by the Contractor
9. Railway Passes
10. Carriage of materials
11. Force Majeure Clause
12. Representation on Works
13. Relics and Treasures
14. Excavated material
15. Indemnity by Contractors
16. Earnest Money and Security Deposit
17. Completion Period
18. Illegal Gratification
19. Execution of Works
20. Compliance to Engineer's Instructions
21. Instructions of Engineer's Representative
22. Adherence to specifications and drawings
23. Working during night
24. Damage to RailTel property or private life and property
25. Sheds, Stores houses and Yards
26. Provision of efficient and competent staff
27. Workmanship and Testing
28. Facilities for Inspection
29. Examination of work before covering up
30. Temporary works
31. Contractors to supply water for works
32. Property in material and plants
33. Tools, Plant and Materials supplied by the RailTel
34. Precaution during progress of work
35. Use of Explosives
36. Suspension of works
37. Rates for items of works
38. Demurrage and wharfage dues
39. Rates for extra items of works
40. Handing over of works
41. Modification to Contract to be in writing
42. Powers of Modification to Contract
43. Monthly Statement of Claims
44. Qualities in schedule annexed to Contract
45. Measurements of Works
46. "On-Account" Payment
47. Maintenance of works
48. Certificate of Completion of Works

49. Approval only by Maintenance Certificate
50. Maintenance Certificate
51. Final payment
52. Withholding and lien in respect of sums claimed
53. Signature on Receipts for Amounts
54. Wages to Labour
55. Provisions of Payments of Wages Act
56. Reporting of Accidents to Labour
57. Provisions of Workmen's Compensation Act
58. RailTel not to provide quarters for Contractor
59. Labour camps
60. Non-Employment of Labourers below the age of 15
61. Determination of Contract
62. Termination of contract owing to default of contractor
63. Matters finally determined by the RailTel
64. Settlement of dispute and Arbitration



GENERAL CONDITIONS OF CONTRACT FOR USE IN CONNECTION WITH RAILTEL'S WORKS

DEFINITIONS AND INTERPRETATION

1. Definitions:

The meaning of terms/interpretations shall be taken as defined in Chapter-3 Part-I of Section-1 (INSTRUCTIONS TO TENDERERS AND CONDITIONS OF TENDERING).

- (a) **"Constructional Plant"** shall mean all appliances or things of whatsoever nature required for the execution, completion or maintenance of the works or the temporary works (as herein after defined) but does not include materials or other things intended to form or forming part of the permanent work.
- (b) **"Temporary Works"** shall mean all temporary works of every kind required for the execution, completion and/or maintenance of the works.
- (c) **"Period of maintenance"** shall mean the specified period of the maintenance from the date of completion of the work as certified by the Engineer.

Singular and Plural: Works importing the singular number shall also include the plural and viceversa where the context requires.

Headings & marginal headings: The headings and marginal headings in these general conditions are solely for the purpose of facilitating reference and shall not be deemed to be part thereof or be taken into consideration in the interpretation or construction thereof or the contract.

2. GENERAL OBLIGATIONS

Execution Co-relation and intent of contract documents:-

The contract documents shall be signed in triplicate by the RailTel and the Contractor. The contract documents are complementary, and what is called for by any one shall be as binding as if called of try all; the intention of the documents is to include all labour and materials, equipments and transportation necessary for the proper execution of work. Materials or work not covered by or properly inferable from any heading or class of the specifications shall not be supplied by the RailTel to the contractors unless distinctly specified in the contract documents. Materials or works described in words, which so applied, have a well-known technical or trade meaning shall be held to refer to such recognized standards.

If a work is transferred from the jurisdiction of one region of RailTel to another region or to a Project authority or vice versa while contract is in subsistence, the contract shall be binding on the Contractor and the other region in the same manner & take effect in all respects as if the Contractor and the other region were parties thereto from the inception and the corresponding officer or the competent authority in the other region will exercise the same powers and enjoy the same authority as conferred to the Predecessor RailTel/Project under the original contract/agreement entered into.

If for administrative or other reasons the contract is transferred to the other region of RailTel the contract shall notwithstanding anything contained herein contrary thereto, be binding on the Contractor and the other region in the same manner and take effect in all respects as if the contractor and the other region had been parties there to from the date of this contract.

3. Law Governing the Contract:

The Contract shall be governed by the law for the time being in force in India.

Compliance to regulations and bye-laws – The Contractor shall conform to the provision of any

statute relating to the works and regulations and bye-laws of any local authority and of any water and lighting companies or undertakings, with whose system the work is proposed to be connected and shall be fore making any variation from the drawings or the specifications that may be necessitated by so confirming give to the Engineer notice specifying the variation proposed to be made and the reason for making the variation and shall not carry out such variation until he has received instructions from the Engineer in respect thereof. The Contractor shall be bound to give all notices required by statute, regulations or bye-laws as aforesaid and to pay all fees and taxes payable to any authority in respect thereof.

4. **Communications to be in writing** – All notices, communications, references and complaints made by the RailTel or the Engineer or the Engineer's representative or the Contractor interest concerning the works shall be in writing and no notice, communication, references or complaint not in writing shall be recognized.
5. **Service of Notices on Contractors**– The Contractor shall furnish to the Executive Director/RailTel the name, designation and address of his authorized agent and all complaints, notices, communications and references shall be deemed to have been duly given to the contract if delivered to the Contractor or his authorized agent or left at or posted to the address so given and shall be deemed to have been so given in the case of posting on day on which they would have reached such address in the ordinary course of post or on the day on which they were so delivered or left. In the case of contract by partners, any change in the constitution of the firm shall be forth with notified by contractor to the Executive Director/RailTel.
6. **Occupation and use of land** – No land belonging to or in the possession of the Railway / RailTel shall be occupied by the contractor without the permission of the RailTel. The Contractor shall not use, or allow to be used, the site for any purposes other than that executing the works.
7. **Assignment or subletting of contract:** - The Contractor shall not assign or sublet the contract or any part thereof or allow any person to become interested therein in any manner whatsoever without the special permission in writing of the RailTel. Any breach of this condition shall entitle the RailTel to rescind the contract under clause 62 of these conditions and also render the contractor liable for payment to the RailTel in respect of any loss or damage arising or ensuring from such cancellation. Provided always that execution of the details of the work by petty contractor under the direct and personal supervision of the contractor or his agent shall not be deemed to be sub-letting under this clause. The permitted subletting of work by the contractor shall not establish any contractual relationship between the sub-contractor and the RailTel and shall not relieve the Contractor of any responsibility under the Contract.
8. **Assistance by the RailTel for the stores to be obtained by the Contractor:** Owing to difficulty in obtaining certain materials (including Tools & Plants) in the market, the RailTel may have agreed without any liability therefore, to endeavor to obtain or assist the Contractor in obtaining the required quantities of such materials as may be specified in the Tender. In the event of delay or failure in obtaining the required quantities of the aforesaid materials, the Contractor shall not be deemed absolved of his own responsibility and shall keep in touch with the day to day position regarding their availability and accordingly adjust progress of works including employment of labour and the RailTel shall not in any way be liable for the supply of materials or for the non supply thereof for any reasons whatsoever not for any loss or damage arising in consequence of such delay or non supply.
9. **Railway Passes** – No free Railway passes shall be issued by the RailTel to the Contractor or any of his employee/worker.
10. **Carriage of materials** – No forwarding orders shall be issued by the RailTel for the conveyance of Contractor's materials, tools and plant by Railway which may be required for use in the works and the contractor shall pay full freight at public tariff rates therefore.
11. **Force Majeure Clause**

If at anytime, during the continuance of this Contract, the performance, in whole or part, by either party, of any obligation under this contract shall be prevented or delayed by reason of anywar, hostility, act of the public enemy, Civil Commotion, Sabotage, Fires, Floods, Earthquakes, explosions, strikes, epidemics, quarantine restrictions, lockouts, any statute, statutory rules/regulations, order of requisitions issued by any Government Department or Competent Authority of acts of God (here-in-after referred to as event) then provided notice of the happening of any such event is given by either party to the other within twenty one days from the date of occurrence thereof, neither party shall, by reason of such event, be entitled to terminate this Contractor shall either party have any claim for damage against the other in respect of such non-performance or delay in performance, and the obligations under the Contract shall be resumed as soon as practicable after such event has come to an end or ceased to exist, PROVIDED FURTHER that if the performance in whole or part of any obligation under this Contract is prevented or delayed by reason of any such event beyond a period as mutually agreed to by the RailTel and the Contractor after any event or 60 days in the absence of such an agreement which ever is more, either party may at its option terminate the Contract provided also that if the contract is so terminated under this clause the RailTel may at the time of such termination take Over from the Contractor at prices as provided for in the contract, all works executed or works under execution.

12. Representation on Works – The Contractor shall, when he is not personally present on the site of the works place and keep a responsible agent at the works during working hours who shall on receiving reasonable notice, present himself to the Executive Director/RailTel and orders given by the Engineer or the Engineer's Representative to the agent shall be deemed to have the same force as if they had been given to the Contractor. Before absenting himself, the Contractor shall furnish the name and address of his agent for the purpose of this clause and failure on the part of the Contractor to comply with this provision at any time will entitle the RailTel to rescind the contract under Clause 62 of these conditions.

13. Relics and Treasures – All gold, silver, oil and other minerals of any description and all precious stones, coins, treasures, relics, antiquities and other similar things which shall be found in or upon the site shall be property of the RailTel and the Contractor shall duly preserve the same to the satisfaction of the RailTel and shall from time to time deliver the same to such person or persons as the RailTel may appoint to receive the same.

14. Excavated material – The Contractor shall not sell or otherwise dispose of or remove except for the purpose of this contract, the sand, stone, clay ballast, earth, rock or other substances or materials which may be obtained from any excavation made for the purpose of the works or any building or produced upon the site at the time of delivery of the possession thereof but all these substances, materials, buildings, and produce shall be the property of the RailTel provided that the Contractor may, with the permission of the Executive Director/RailTel, use the same for the purpose of the works either free of cost or pay the cost of the same at such rates as may be determined by the Engineer.

15. Indemnity by Contractors – The Contract shall indemnify and save harmless the RailTel from and against all actions, suit proceedings, losses, costs, damages, charges, claims, and demands of every nature and description brought or recovered against the RailTel's by reason of any act or omission of the Contractor, his agents or employees, in the execution of the works or in his guarding of the same. All sums payable by way of compensation under any of these conditions shall be considered as reasonable compensation to be applied to the actual loss or damage sustained, and whether or not any damages shall have been sustained.

16. Security Deposit

The Earnest Money deposited by the Contractor with his tender will be retained by RailTel as part of security deposit for the due and faithful fulfillment of the contract by the contractor. The balance to make up the security deposit, may be deposited by Contractor in the form of Demand Drafts or maybe recovered by percentage deduction from the contractor's "on account" bills. Provided also that in case of defaulting contractor the RailTel may retain any amount due for payment to the Contractor on the pending "on account bills" so that the amounts so retained may not exceed 5%

of the total value of the contract.

Unless otherwise specified in the special conditions, if any, the rates for Deposit/rate of recovery /mode of recovery shall be as under:

- a) Security Deposit for each work should be 5% of the contract value.

Security Deposit shall be returned to the contractor after the physical completion of the work as certified by the competent authority. The competent authority shall normally be the authority that is competent to sign the contract.

No interest will be payable upon the Earnest Money and Security Deposit or amounts payable to the Contractor under the Contract.

17 **Completion Period:-**

Subject to any requirement in the contract as to completion of any portion or portions of the works before completion of the whole, the contractor shall fully and finally complete the whole of the works comprised in the contract (with such modifications as may be directed under conditions of this contract) by the date entered in the contract or extended date in terms of the following clauses:

If any modifications have been ordered which in the opinion of the Engineer have materially increased the magnitude of the work, then such extension of the contracted date of completion may be granted as shall appear to the Engineer to be reasonable in the circumstances, provided more over that the Contractor shall be responsible for requesting such extension of the date as may be considered necessary as soon as the clause thereof shall arise and in any case not less than one month before the expiry of the date fixed for completion of the works.

If in the opinion of the Engineer the progress of work has any time been delayed by any act or neglect of RailTel's employees or by other contractor employed by the RailTel under sub-clause (4) of clause 20 of these conditions or in executing the work not forming part of the contract but on which contractor's performance necessarily depends or by reason of proceeding taken or threat-tended by or dispute with adjoining or neighboring owners or public authority arising otherwise through the Contractor's own default etc. or by the delay authorized by the Engineer pending arbitration or in consequences of the contractor not having received in due time necessary instructions from the RailTel for which he shall have specially applied in writing to the Engineer or his authorized representative then upon happening of any such event causing delay, the contractor shall immediately give notice thereof in writing to the Engineer within 15 days of such happening but shall nevertheless make constantly his best endeavors to bring down or make good the delay and shall do all that may be reasonably required of him to the satisfaction of the Engineer to proceed with the works. The contractor may also indicate the period for which the work is likely to be delayed and shall be bound to ask for necessary extension of time. The engineer on receipt of such request from the contractor shall consider the same and shall grant such extension of time as in his opinion is reasonable having regard to the nature and period of delay and the type and quantum of work affected thereby. No other compensation shall be payable for works so carried forward to the extended period of time, the same rates, terms and conditions of contract being applicable as if such extended period of time was originally in the original contract itself.

In the event of any failure or delay by the RailTel to hand over the Contractor possession of the lands necessary for the execution of the works or to give the necessary notice to commence the works or to provide the necessary drawings or instructions or any other delay caused by the RailTel due to any other cause whatsoever, then such failure or delay shall in no way affect or vitiate the contractor alter the character thereof or entitle the contractor to damages or compensation therefore but in any such case, the RailTel may grant such extension or extensions of the completion date as may be considered reasonable.

Extension of time for delay due to contractor – The time for the execution of the work or part of the

works specified in the contract documents shall be deemed to be the essence of the contract. If the contractor fails to complete the works within the time as specified in the contract for the reasons other than the reasons specified in clause 11 and 17.1 above, the RailTel may, if satisfied that the works can be completed by the contractor within reasonable short time thereafter, allow the contractor further extension of time as the Engineer may decide. On such extension the RailTel will be entitled without prejudice to any other right and remedy available on that behalf, to recover from the contractor as agreed damages and not by way of penalty a sum equivalent to 1/2% of the contract value of the works for each week or part of the week.

For the purpose of this clause, the contract value of the works shall be taken as value of work as per contract agreement including any supplementary work order /contract agreement issued. Provided also, that the total amount of liquidated damages under this condition, shall not exceed 10% of the total value of the contract. Provided further, that if the RailTel is not satisfied that the works can be completed by the Contractor and in the event of failure on the part of the contractor to complete the work within further extension of time allowed as aforesaid, the RailTel shall be entitled, without prejudice to any other right or remedy available in that behalf, to appropriate the contractor's security deposit and rescind the contract under clause 62 of these conditions, whether or not actual damage is caused by such default.

18. **Illegal Gratification**

Any bribe, commission, gift or advantage given, promised or offered by or on behalf to the Contractor or his partner, agent or servant or anyone on his behalf, to any officer or employees of the RailTel, or to any person on his behalf in relation to obtaining or the execution of this or any other contract with the RailTel shall, in addition to any criminal liability which he may incur, subject the contractor to the rescission of the contract and all other contracts with the RailTel and to the payment of any loss or damage resulting from such decision and the RailTel shall be entitled to deduct the amounts so payable from any moneys due to the Contractor (s) under this contractor any other contracts with the RailTel.

The Contractor shall not lend or borrow from or have or enter into any monetary dealings or transactions either directly or indirectly with any employee of the RailTel and if he shall do so, the RailTel shall be entitled forthwith to rescind the contract and all other contracts with the RailTel. Any question or dispute as to the commission or any offence or compensation payable to the RailTel under this clause shall be settled by the Executive Director of RailTel, in such a manner as shall consider fit and sufficient and his decision shall be final and conclusive.

In the event of rescission of the contract under this clause, the Contractor will not be paid any compensation whatsoever except payments for the work done up-to-date of rescission.

19. **EXECUTION OF WORKS**

Contractor's understanding – It is understood and agreed that the Contractor has, by careful examination, satisfied himself as to the nature and location of the work, the conformation of the ground, the character, quality and quantity of the materials to be encountered, the character of equipment and facilities needed preliminary to and during the progress of the works, the general and local conditions, the labour conditions prevailing therein and all other matters which can in any way affect the works under the contract.

Commencement of works – The Contractor shall commence the works within 15 days after the receipt by him of an order in writing to this effect from the RailTel and shall proceed with the same with due expedition and without delay.

Accepted programme of work – The Contractor who has been awarded the work shall as soon as possible but not later than 7 days from the date of receipt of the acceptance letter in respect of contracts with initial completion period of one year or less or not later than 15 days for other contracts have to submit the detailed programme of work indicating the time schedule of various items of works in the form of BarChart /PERT/CPM. He shall also submit

the details of organization (in terms of labour and supervisors) plant and machinery that he intends to utilize (from time to time) for execution of the work within stipulated date of completion. The programme of work amended as necessary by discussions with the Engineer, shall be treated as the agreed programme of the work for the purpose of this contract and the contractor shall endeavor to fulfill this programme of work. The progress of work will be watched accordingly in the liquidated damages will be with reference to the overall completion date. Nothing stated herein shall preclude the contractor in achieving earlier completion of item or whole of the works than indicated in the programme.

- 19.4 **Setting out of works**– The Contractor shall be responsible for the correct setting out of all works in relation to original reference at his cost. The Contractor shall execute the work true to specifications, drawings, plans and dimensions as mentioned in the contract document and as directed by the Engineer's representative and shall check these at frequent intervals. The Contractor shall provide all facilities like labour and instruments and shall cooperate with the Engineer's representative at all time, during the progress of the works. Any error shall appear or arise in any part of the work, the Contractor, on being required so to do by the Engineer's representative shall, at his own rectify such errors, to the satisfaction of the Engineer's representative. Such checking shall not absolve the Contractor of his own responsibility of maintaining accuracy in the work.

20 **Compliance to Engineer's Instructions**

The Engineer shall direct the order in which the several parts of the works shall be executed and the Contractor shall execute without delay all orders given by the Engineer from time to time but the Contractor shall not be relieved thereby from responsibility for the due performance of the works in all respects.

Alterations to be authorized – No alterations in or additions to or omissions or abandonment of any part of the works shall be deemed authorized, except under instructions from the Engineer, and the Contractor shall be responsible to obtain such instructions in each and every case in writing from the Engineer.

Extra Works – Should works over and above those included in the contract require to be executed at the site, the contractor shall have no right to be entrusted with the execution of such works, which may be carried out by another contractor or contractors or by other Mean at the option of the RailTel.

Separate Contracts in connection with works – The RailTel shall have the right to let other contracts in connection with the works. The Contractor shall afford other contractors reasonable opportunity for the storage of their materials and the execution of their works and shall properly connect and coordinate his work with theirs. If any part of the Contractor's work depends for proper execution or result upon the work of another contractor(s) the Contractor shall inspect and promptly report to the Engineer any defects in such works that render it unsuitable for such proper execution and results. The Contractor failure so to inspect and report shall constitute an acceptance of the other contractor's work as fit and proper for the reception of his work, except as to defects which may develop in the other contractor's work after the execution of his work.

21. **Instructions of Engineer's Representative**–Any instructions or approval given by the Engineer's representative to Contractor in connection with the works shall bind the Contractor as though it had been given by the Engineer provided always as follows:-

Failure of the Engineer's representative to disapprove any work or materials shall not prejudice the power of the Engineer thereafter to disapprove such work or material and to order the removal or breaking up thereof.

If the Contractor shall be dissatisfied by reason of any decision of the Engineer's representative, he shall be entitled to refer the matter to the Engineer who shall there-upon confirm or vary such decision.

22. Adherence to specifications and drawings

The whole of the works shall be executed in perfect conformity with the specifications and drawings of the contract. If the Contractor performs any works in a manner contrary to the specifications or drawings or any of them and without such reference to the Engineer, he shall bear all the costs arising or ensuring therefrom and shall be responsible for all loss to the RailTel.

Drawings and specifications on the works – The contractor shall keep one copy of Drawings and specifications at the site, in good order, and such contract documents as may be necessary, available to the Engineer or the Engineer's Representative.

The supply of equipment and materials shall include supply of one set of printed documents from original equipment manufacturers with each equipment as given in technical supplement.

Ownership of Drawings and Specifications– All drawings and Specifications and copies thereof furnished by the RailTel to the Contractor are deemed to be the property of the RailTel. They shall not be used for any other works and with the exception of the signed contract set, shall be returned by the Contractor to the RailTel on completion of the work or termination of the Contract.

Compliance with Contractor's request for details– The Engineer shall furnish with reasonable promptness, after receipt by him of the Contractor's request for the same, additional instructions by means of drawings or otherwise, necessary for the proper execution of the works or any part thereof. All such drawings and instructions shall be consistent with the Contract Documents and reasonably inferable therefrom.

Meaning and Intent of specification and drawings – If any ambiguity arises as to the meaning and intent of any portion of the Specifications and Drawings or as to execution or quality of any work or material, or as to the measurements of the works the decision of the Engineer thereon shall be final subject to the appeal (within 7 days of such decision being intimated to the Contractor) to the competent authority in RailTel who shall have the power to correct any errors, omissions, or discrepancies in the aforementioned items and whose decision in the matter in dispute or doubt shall be final and conclusive.

23 Working during night– The Contractor shall not carry out any work between sunset and sunrise without the previous permission of the Engineer.

24. Damage to Railways/RailTel property or private life and property – The Contractor shall be responsible for all risk to the works and for trespass and shall make good at his own expense all loss or damage whether to the works themselves or any other property of the Railways/RailTel or the lives, persons or property of others from whatsoever cause in connection with the works until they are taken over by the RailTel and this although all reasonable and proper precautions may have been taken by the Contractor, and in case the RailTel shall be called upon to make good any costs, loss or damages, or to pay any compensation, including that payable under the provisions of the Workmen's Compensation Act or any statutory amendments thereof to any person or persons sustaining damages as aforesaid by reason of any act, or any negligence or omissions on the part of the Contractor the amount of any costs or charges including costs and charges in connection with legal proceedings, which the RailTel may incur in reference thereto, shall be charged to the Contractor. The RailTel shall have the power and right to pay or to defend or compromise any claim of threatened legal proceedings or in anticipation of legal proceedings being instituted consequent on the action or default of the Contractor, to take such steps as may be considered necessary or desirable to ward off or mitigate the effect of such proceedings, charging to

Contractor, as aforesaid, any sum or sums of money which may be paid and any expenses whether for reinstatement or otherwise which may be incurred and the propriety of any such payment, defense or compromise, and the incurring of any such expenses shall not be called in question by the Contractor.

25. Sheds, Stores houses and Yards– The Contractor shall at his own expense provide himself with

sheds, storehouses and yards in such situations and in such numbers as in the opinion of the Engineer is requisite for carrying on the works and the Contractor shall keep at each such sheds,

store houses and yards a sufficient quantity of materials and plant in stock as not to delay the carrying out of the works with due expedition and the Engineer and the Engineer's representatives shall have free access to the said sheds, store houses and yards at any time for the purpose of inspecting the stock of materials or plant so kept in hand, and any materials or plant which the Engineer may object to shall not be brought upon or used in the works, but shall be forthwith removed from the sheds, store houses or yards by the contractor. The Contractor shall at his own expenses provide and maintain suitable mortar mills, soaking vats or any other equipments necessary for the execution of the works.

- 26. Provision of efficient and competent staff** – The Contractor shall place and keep on the works at all times efficient and competent staff to give the necessary directions to his workmen and to see that they execute their work in sound and proper manner and shall employ only such supervisors, workmen and labourers in or about the execution of any of these works as are careful and skilled in various trades and callings. The Contractor shall at once remove from the works any agents, permitted sub-contractor, supervisor, workman or labourer who shall be objected to by the Engineer and if and whenever required by the Engineer, he shall submit a correct return showing the names of all staff and workmen employed by him. In the event of the Engineer being of the opinion that the Contractor is not employing on the works a sufficient number of staff and workmen as is necessary for the proper completion of the works within the time prescribed, the Contractor shall forthwith on receiving intimation to this effect take on the additional number of staff and labour specified by the Engineer within seven days of being so required and failure on the part of the Contractor to comply with such instructions will entitle the RailTel to rescind the contract under Clause 62 of these conditions.

27. Workmanship and Testing

The whole of the works and/or supply of materials specified and provided in the contract or that may be necessary to be done in order to form and complete any part thereof shall be executed in the best and most substantial workman like manner with materials of the best and most approved quality of their respective kinds, agreeable to the particulars contained in or implied by the specifications and as referred to in and represented by the drawings or in such other additional particulars. Instructions and drawings may be found requisite to be given during the carrying on of the works and to the entire satisfaction of the Engineer according to the instructions and directions, which the Contractor may from time to time receive from the Engineer. The materials may be subjected to tests by means of such machines, instruments and appliances as the Engineer may direct and wholly at the expense of the Contractor.

Removal of Improper work and materials – The Engineer or the Engineer's representative shall be entitled to order from time to time:-

There removal from the site with in the times pecified in the order of any materials, which in his opinion are not in accordance with the specification or drawings.

The substitution of proper and suitable materials, and

The removal and proper re-execution, notwithstanding any previous tests thereof or "on account" payments therefore, of any work which in respect of materials or work manship is not in his opinion in accordance with the specifications and in case of default on the part of the Contractor in carrying out such order the RailTel shall be entitled to rescind the contract under Clause 62 of these conditions.

- 28. Facilities for Inspection:** -The Contractor shall afford the Engineer and the Engineer's Representative every facility for entering in and upon every portion of the work at all hours for the purpose of inspection or otherwise and shall provide all labour, materials, instruments, appliances and things of every kinds required for the purpose and the Engineer and the Engineer's representative shall at all time have free access to every part of the works and to all places at which materials for the work are stored or being prepared.
- 29. Examination of work before covering up:** - The Contractor shall give two days notice to the Engineer or the Engineer's Representative whenever any work or materials are intended to be covered up

in the earth, in bodies or walls or otherwise to be placed beyond the Reach of Measurements in order that the work may be inspected or that correct dimension may be taken before being so covered, placed beyond the reach of measurement in default whereof, the same shall at the option of the Engineer or the Engineer's Representative be uncovered and measured at the contractor's expense or no allowance shall be made for such work or materials.

- 30. Temporary works:** - All Temporary works necessary for the proper execution of the works shall be provided and maintained by the Contractor and subject to the consent of the Engineer, shall be removed by him at his expenses when they are no longer required and in such manner as the Engineer shall direct. In the event of failure on the part of the Contractor to remove the temporary works, the Engineer will cause them to be removed and cost as increased by supervision and other incidental charge shall be recovered from the Contractor. If temporary huts are provided by the Contractor on the Railway land for labour engaged by him and the work is completed but the contractor's labour refused to vacate and have to be removed by the RailTel, necessary expenses incurred by the RailTel in connection therewith shall be borne by the Contractor.

31. Contractor to supply water for works

Unless otherwise provided in the contract, the contractor shall be responsible for arrangements to obtain supply of water for the works.

Water supply from the Railway system

Water supply by Railway Transport: Deleted

Contractor to arrange supply of Electric power for works

Unless otherwise provided in the contract, the contractor shall be responsible for arrangements to obtain supply of Electric Power for the works.

Electric supply from the Railway system – The RailTel may supply to the Contractor part or whole of the electric power wherever available and possible, required for execution of works from the Railway's existing electric supply systems at or near the site of works on specified terms and conditions and such charges as shall be determined by the RailTel and payable by the contractor provided the cost of arranging necessary connection to the Railway's Electric supply systems, and laying of underground/ overhead conducts circuit protection, electric power meters, transmission structure, shall be borne by the Contractor and that the contractor shall not be entitled to any compensation for interruption or failure of the Electric supply system.

32. Property in material and Plants: Deleted

33. Tools, Plant and Materials Supplied by the RailTel. (Not Applicable)

The Contractor shall take all responsible care of all tools, plants and materials or other property whether of a like description or not belonging to the RailTel and committed to his charge for the purpose of the works and shall be responsible for all damage or loss caused by him, his agents permitted sub-contractor or his workmen or others while they are in his charge. The Contractor shall sign accountable receipts for tools, plants and materials made over to him by the Engineer and on completion of the works shall handover the unused balance of the same to the Engineer in good order and repair, fair wear and tear excepted and shall be responsible for any failure to account for the same or any damaged one there to.

Hire of RailTel's Plant: Deleted.

34. Precaution during progress of work:

During the execution of works, unless otherwise specified the Contractor shall at his own cost provide the materials for and execute all shoring, time being and strutting works as is necessary for the stability and safety of all structures, excavations and works and shall ensure that

no damage, injury, loss is caused or likely to be caused to any person or property.

Roads and watercourses: Existing roads or watercourses shall not be blocked, cut through, altered, diverted or obstructed in any way by the Contractor, except with the permission of the Engineer. All compensations claimed for any authorized closure, or his agent or his staff shall be recoverable from the Contractor by deduction from any sums which may become due to him in terms of contract or otherwise according to law.

Provision of access to premises: During progress of work in any street or thoroughfare, the Contractor shall make adequate provision of the passage of traffic, for securing safe access to all premises approached from such street or thoroughfare and for any drainage, water supply or meant for lightning which may be interrupted by reason of the execution of the works and shall erect and maintain at his own cost barriers, lights and other safeguards as prescribed by the Engineer, for the regulation of the traffic, and provide watchmen necessary to prevent accidents. The works shall in such cases be executed night and day if so ordered by the Engineer and with such vigour so that the traffic way be impeded for as short a time as possible.

Safety of Public: The Contractor shall be responsible to take all precautions to ensure the safety of the public or Railway/RailTel's property and shall post such look out men as may in the opinion of the Engineer be required to comply with regulations pertaining to the work.

35. Use of Explosives: Explosive shall not be used on the works or on the site by the Contractor without the permission of the Engineer and then only in the manner and to the extent to which such permission is given. Where explosives are required for the works, the same shall be stored in a special magazine to be provided by and at the cost of the Contractor in accordance with the Explosive Rules. The Contractor shall obtain the necessary license for the storage and the use of explosives and all operations in which or for which explosives are employed shall be at the sole risk and responsibility of the Contractor and the Contractor shall indemnify the Railway/RailTel in respect thereof.

36. Suspension of works

The Contractor shall on the order of Engineer suspend the progress of the works or any part thereof for such time or times and in such manner as the Engineer may consider necessary and shall during such suspension properly protect and secure the work so far as is necessary in the opinion of the Engineer. If such suspension is:-

- (a) Provided for in the contract, or
- (b) Necessary for the proper execution of the works or by there as on of weather conditions or by some default on the part of the Contractor, and or
- (c) Necessary for the safety of the works or any part thereof.

The Contractor shall not be entitled to the extra costs, if any, incurred by him during the period of suspension of the works; but in the event of any suspension ordered by the Engineer for reasons other than aforementioned and when each such period of suspension exceeds 14 days, the Contractor shall be entitled to such extension of time for completion of the works as the engineer may consider proper having regard to the period or periods of such suspensions and to such compensations as the Engineer may consider reasonable in respect of salaries or wages paid by the Contractor to his employees during the periods of such suspensions.

Suspension lasting more than 3 months – If the progress of the works or any part thereof is suspended on the order of the Engineer for more than three months at a time, the Contractor may serve a written notice on the Engineer requiring permission within 15 days from the receipt thereof to proceed with the works or that part thereof in regard to which progress is suspended and if such permission is not granted within that time the Contractor by further written notice so served may, but is not bound to, elect to treat the suspension where it affects part only of the works as an omission of such part or where it affects the whole of the works, as an abandonment of the contract by the RailTel.

- 37. Rates for items of works** – The rates entered in the accepted Schedule of Rates of the Contract are intended to provide for works duly and properly completed in accordance with the general and special conditions of the contract and the specifications and drawings together with such enlargements, extensions, diminutions, reductions, alterations or additions as may be ordered in terms of Clause 42 of these conditions and without prejudice to the generality thereof and shall be deemed to include and cover superintendence and labour, supply including full freight of materials, stores, tools and all apparatus and plant required on the works, except such tools, plant or materials as may be specified in the contract to be supplied to the Contractor by the RailTel, the erection, maintenance and removal of all temporary works and buildings, all arrangements for the safety of the public or of employees during the execution of works, all sanitary and medical arrangements for labour camps as may be prescribed by the RailTel, the setting of all work and of the construction, repair and up keep of all center lines, benchmark and level pegs

thereon, site clearance, all fees, duties, royalties, rent and compensation to owners for surface damage or taxes and impositions payable to local authorities in respect of land, structures and all material supplied for the work or other duties or expenses for which the Contractor may become liable or may be put to under any provision of law for the purpose of or in connection with the execution of the contract, and all such other incidental charges or contingencies as may have been specially provided for in the specifications.

- 38. Demurrage and wharfage dues**

Demurrage charges calculated in accordance with the scale in force for the time being on the RailTel and incurred by the Contractor failing to load or unload any goods or materials within the time allowed by RailTel for loadings as also wharfage charges, of materials not removed in time also charges due

on consignments booked by or to him shall be paid by the Contractor, failing which such charges shall be debited to the Contractor's account in the hands of the RailTel and shall be deducted from any sums which may become due to him in terms of the contracts.

- 39. Rates for extra items of works**

Any item of work carried out by the Contractor on the instructions of the Engineer which is not included in the accepted schedule of rates shall be executed at the rates set forth in the "Schedule of Rates" modified by the tender percentage and such items are not contained in the latter, at the rate agreed upon between the Engineer and the Contractor before the execution of such items of work and the contractor shall be bound to notify the Engineer at least seven days before the necessity arises for the execution of such items of works that the accepted schedule of rates does not include rate or rates for the extra work involved. The rates payable for such items shall be decided at the meeting to be held between the Engineer and Contractor, in as short a period as possible after the need for the special item has come to the notice. In case the Contractor fails to attend the meeting after being notified to do so or in the event of no settlement being arrived at, the RailTel shall be entitled to execute the extra works by other means and the contractor shall have no claim for loss or damage that may result from such procedure.

Provided that if the Contractor commences work or incurs any expenditure in regard thereto before the rates as determined and agreed upon as lastly hereunto fore mentioned, then and in such a case the Contractor shall only be entitled to be paid in respect of the work carried out or expenditure incurred by him prior to the date of determination of the rates as aforesaid according to the rates as shall be fixed by the Engineer. However if the contractor is not satisfied with the decision of the Engineer in this respect he may appeal to the competent authority of RailTel within 30 days of getting the decision of the Engineer, supported by analysis of the rates claimed. The competent authority of RailTel's decision after hearing both the parties in the matter would be final and binding on the Contractor.

- 40. Handing over of works:**

The Contractor shall be bound to hand over the works executed under the contract to the RailTel complete in all respect to the satisfaction of the Engineer. The Engineer shall determine the

date on which the work is considered to have been completed, in support of which his certificate shall be regarded as sufficient evidence for all purposes. The engineer shall determine from time to time, the date on which any particular section of the work shall have been completed, and the contractor and the contractor shall be bound to serve any such determination of the Engineer.

Clearance of Site on Completion: On completion of the works the Contractor shall clear away and remove from the site all constructional plant, surplus materials, rubbish and temporary works of every kind and leave the whole of the site and works clean and in a workman like condition to the satisfaction of the Engineer. No final payment in settlement of the accounts for the work shall be paid, held to be due or shall be made to the contractor till, in addition to any other condition necessary for such final payment, site clearance shall have been effected by him, and such clearance may be made by the Engineer at the expense of the Contractor in the event of his failure to comply with this provision within 7 days after receiving notice to that effect. Should it become necessary for the Engineer to have the site cleared at the expense of the Contractor, the RailTel shall not be held liable for any loss or damage to such of the Contractor's property as may be on the site and due to such removal, there from which removal may be affected by means of public sales of such materials and property or in such a way as deemed fit and convenient to the Engineer.

VARIATIONS IN EXTENT OF CONTRACT

41. Modification to Contract to be in writing – In the event of any of the provisions of the Contract requiring to be modified after the contract documents have been signed, the modifications shall be made in writing and signed by the RailTel and the Contractor, and no work shall proceed under such modifications until this has been done. Any verbal or written arrangement abandoning, modifying, extending, reducing or supplementing the Contractor any of the terms thereof shall be deemed conditional and shall not be binding on the RailTel unless and until the same is incorporated in a formal instrument and signed by the RailTel and the Contractor and till then the RailTel shall have the right to repudiate such arrangement.

42. Powers of Modification to Contract

The Engineer on behalf of the RailTel shall be entitled by order in writing to enlarge or extend, diminish or reduce the works or make any alterations in their design, character, position, site quantities, dimensions or in the method of their execution or in the combination and use of materials for the execution thereof or to order any additional work to be done or any works not to be done and the Contractor will not be entitled to any compensation for any increase / reduction in the quantities of work but will be paid only for the actual amount of work done and for approved materials supplied against a specific order.

42.2.1 Unless otherwise specified in the special conditions of the contract, the accepted variation in quantity for each individual item of the contract would be up to $\pm 25\%$ of the quantity originally contracted. The contractor shall be bound to carry out the work at the agreed rates and shall not be entitled to any claim or any compensation, whatsoever upto the limit of $\pm 25\%$ variation in quantity of individual items of works.

42.3 Valuation of Variations – The enlargements, extensions, diminution, reduction, alterations or additions referred to in sub-clause (2) of this clause shall in no degree affect the validity of the contract but shall be performed by the Contractor as provided therein and be subject to the same conditions, stipulations and obligations as if they had been originally and expressly included and provided for in the specifications and drawings and the amounts to be paid therefore shall be calculated in accordance with the accepted schedule of rates. Any extra items/quantities of work

falling outside the purview of the provisions of sub-clause (2) above shall be paid for at the rates determined under clause 39 of these conditions.

CLAIMS**43. Monthly Statement of Claims**

The contractor shall prepare and furnish to the Engineer once in every month an account giving full and detailed particulars of all claims for any additional expenses to which the Contractor may consider himself entitled to and of all extra or additional works ordered by the Engineer which he has executed during the preceding month and no claim for payment for and such work will be considered which has not been included in such particulars.

Signing of “No Claim” Certificate – The Contractor shall not be entitled to make any claim whatsoever against the RailTel under or by virtue of or arising out of this contract, nor shall the RailTel entertain or consider any such claim, if made by the Contractor, after he shall have signed a ‘No Claim’ certificate in favour of the RailTel, in such form as shall be required by the RailTel, after the works are finally measured up. The Contractor shall be debarred from disputing the correctness of the items covered by “No Claim Certificate” or demanding a preference to arbitration in respect thereof.

MEASUREMENTS, CERTIFICATES AND PAYMENTS

44. Qualities in schedule annexed to Contract- The quantities set out in the accepted schedule of rates with items of works quantified are the estimated quantities of the works and they shall not be taken as the actual and correct quantities of the works to be executed by the Contractor in fulfillment of his obligations under the contract.

45. Measurements of Works: The Contractor shall be paid for the works at the rates in the accepted schedule of rates and for extra works at rates determined under Clause 39 of these conditions on the measurements taken by the Engineer or the Engineer’s representative in accordance with the rules prescribed for the purpose by the RailTel. The quantities for items the unit of which in the accepted schedule of rates is 100 or 1000 shall be calculated to the nearest whole number, any fraction below half being dropped and half and above being taken as one; for item the unit of which in the accepted schedule of rates is single, the quantities shall be calculated to places of decimals. Such measurements will be taken of the work in progress from time to time and at such intervals as in the opinion of the Engineer shall be proper having regard to the progress of works. The date and time on which “on account” or final measurements are to be made shall be communicated to the Contractor who shall be present at the site and shall sign the results of the measurements (which shall also be signed by the Engineer or the Engineer’s representative) recorded in the official measurements book as an acknowledgement of his acceptance of the accuracy of the measurements. In the absence of the Contractor’s attendance, the work may be measured up in his absence and such measurements shall, notwithstanding such absence, be binding upon the Contractor whether or not he shall have signed the measurement book provided always that any objection made by him to measurement shall be duly investigated and considered in the manner set out below:

- (a) It shall be open to the Contractor to take specific objection to any recorded measurement or Classification on any ground within seven days of the date of such measurements. Any re-measurement taken by the Engineer or the Engineer’s representative in the presence of the Contractor or in his absence after due notice has been given to him in consequence of objection made by the contractor shall be final and binding on the Contractor and no claim whatsoever shall thereafter be entertained regarding the accuracy and classification of the measurement.
- (b) If an objection raised by the Contractor is found by the Engineer to be incorrect the Contractor shall be liable to pay the actual expenses incurred in measurements.

46. “On-Account” Payments

The Contractor shall be entitled to be paid from time to time by way of “On Account” payment only for

such works as in the opinion of the Engineer he has executed in terms of the contract. All payment due on the Engineer's or the Engineer's Representatives certificate of measurement shall be subject to any deduction which may be made under these presents provided always that the Engineer may by any certificate make any correction or modification in any previous certificate which shall have been issued by him and that the Engineer may withhold any certificate if the works or any part thereof are not being carried out to his satisfaction.

Rounding off amounts: The total amount due on the certificate shall be rounded off to the nearest rupee i.e. sums less than 50 paise shall be omitted and sums of 50 paise and more up to Rs.1/- will be reckoned as Rs.1/-.

On-Account Payments not prejudicial to final settlements:

"On Account" payments made to the Contractor shall be without prejudice to the final making up of the accounts (except where measurement are specifically noted in the Measurement Book as "Final Measurements" and as such have been signed by the Contractor) and shall in no respect be considered or used as evidence of any facts stated in or to be inferred from such account not of any particular quantity of work having been executed not of the manner of its execution being satisfactory.

Manner of payment:

Unless otherwise specified payments to the Contractor will be made through RTGS.

47. **Maintenance of works:** The Contractor shall at all times during the progress and continuance of the works and also for the period of maintenance specified in the tender form after the date of passing of the certificate of completion by the Engineer or any other earlier date subsequent to the completion of the works that may be fixed by the Engineer be responsible for and effectively maintain and uphold in good substantial sound and perfect conditions all and every part of the work and shall make good from time to time and at all times as often as the Engineer shall require, any damage or defect that may during the above period arise in or be discovered or be in any way connected with the works, provided that such damage or defect is not directly caused by errors in the contract documents, act of providence or insurrection or civil riot, and the Contractor shall be liable for and shall pay and make good to the RailTel or other persons legally entitled thereto whenever required by the Engineer so to do, all losses, damage, costs and expenses they or any of them may incur or be put or be liable or, by reason or in consequence of the operations of the Contractor or of his failure in any respect.

For this purpose, the tenderer will submit their strategy for providing maintenance support including the staff who will be available along with the set of spares for attending to various faults/problems during maintenance period.

48. **Certificate of Completion of works**

As soon as in the opinion of the Engineer the works shall have been substantially completed and shall satisfactorily pass any final test or tests that may be prescribed, the Engineer shall issue a Certificate of the completion (Provisional Acceptance Certificate) in respect of the works and period of maintenance of the works shall commence from the date of such certificate provided that the Engineer may issue such a certificate with respect to any part of the works before the completion of the whole of the works or with respect to any substantial part of the works which has been both completed to the satisfaction of the Engineer and occupied or used by the RailTel and when any such certificate is given in respect of part of the works such part shall be considered as completed and the period of the maintenance of such part shall commence from the date of such certificate.

Contractor not absolved by Provisional Completion Certificate (PAC): The Certificate of completion in respect of the works referred to in sub-clause 48.1 of this clause shall not absolve the Contractor from his liability to make good any defect, imperfection, shrinkages or faults which may appear during the period of maintenance specified in the tender arising in the opinion of the Engineer from materials or workmanship not in accordance with the drawing or specifications or instructions of the Engineer, which defect, imperfections, shrinkages or faults shall upon the direction in writing of the Engineer, be amended and made good by the Contractor at his own cost; and in case of default on the

part of Contractor the Engineer may employ, labour and material or appoint another Contractor to amend and make good such defect, imperfections, shrinkages and faults and all expenses consequent thereon and incidental thereto shall be borne by the Contractor and shall be recoverable from any moneys due to him under the contract.

49. **Approval only by Maintenance Certificate/Final Acceptance Certificate (FAC):** No certificate other than maintenance certificate referred to in Clause 50 of the conditions shall be deemed to constitute approval of any work or other matter in respect of which it is issued or shall be taken as an admission of the due performance of the contract or any part thereof or of the accuracy of any claim or demand made by the Contractor or of additional varied work having been ordered by the Engineer nor shall any other certificate conclude or prejudice any of the powers of the Engineers.

50 Maintenance Certificate (FAC)

The contract shall not be considered as completed until a maintenance certificate (Final Acceptance Certificate) shall have been signed by the Engineer stating that the works have been

completed and maintained to his satisfaction. The maintenance certificate shall be given by the Engineer upon the expiration of the period of maintenance or as soon thereafter as any work ordered during such period pursuant to clause 48.2 of these conditions shall have been completed to the satisfaction of the Engineer and full effect shall be given to this Clause notwithstanding the taking possession of or using the works or any part thereof by RailTels.

Cessation of RailTel's Liability: The RailTel shall not be liable to the Contractor for any matter arising of or in connection with the contract of the execution of the works unless the Contractor shall have made a claim in writing in respect thereof before the issue of the Maintenance Certificate (FAC) under this clause.

Unfulfilled obligations: Notwithstanding the issue of the Maintenance Certificate the Contractor and (subject to clause 50.2) the RailTel shall remain liable for the fulfillment of any obligation incurred under the provision of the contract prior to the issue of the maintenance Certificate which remains unperformed at the time such certificate is issued and for the purposes of determining the nature and extent of any such obligations the contract shall be deemed to remain in force between the parties thereto.

51. Final payment

On the Engineer's certificate of completion in respect of the works an adjustment shall be made and the balance of account based on the Engineer or the Engineer's representative's on the accepted schedule or rates and for extra works on rates determined under Clause 39 of these conditions shall be paid to the Contractor subject always to any deduction which may be made under these presents and further subject to the Contractor having delivered to the Engineer either a full account in detail of all claims he may have on the RailTel in respect of the works or having delivered "No Claim" Certificate and the Engineer having after the receipt of such account given a certificate in writing that such claim are correct, that the whole of the works to be done under the provisions of the Contracts have been completed, that they have been inspected by him since their completion and found to be in good and substantial order, that all properties, works and things removed, disturbed or injured in consequence of the works have been properly replaced and made good and all expenses and demands incurred by or made upon the RailTel for or in the respect of damage or good and all expenses and demands incurred by or made upon the RailTel for or in the respect of damage or loss by from kin consequence of the works, have been satisfied agreeably and in conformity with the contract.

Post payment Audit – It is an agreed term of contract that the RailTel reserves to itself the right to carry out a post-payment audit and/or technical examination of the works and the final bill including all supporting vouchers, abstracts, etc., and to make a claim on the contractor for the refund of any

excess amount paid to him if as a result of such examination any over-payment to him is discovered to have been made in respect of any work done or alleged to have been done by him under the contract.

Refund of security deposit—The total security deposit shall become due and shall be paid to the Contractor or after the expiration of the warranty period and issue of the certificate of final acceptance of entire system, specified in the tender, provided that all the stipulations of the clause have been fulfilled by the Contractor and all claim and demands made against the RailTel for and in respect of damage or loss by, from or in consequence of the works have been finally satisfied, provided further that in the event of different maintenance periods having become applicable to different parts of the works pursuant to subclause (i) of clause 48 of the set condition, the expression “expiration of the period of warranty shall for the purpose of this clause, be deemed to mean the expiry of the latest of such periods”.

Production of vouchers etc. by the Contractor

- (i) For a contract of more than one crore of rupees, the contractor shall, whenever required, produce for examination by the Engineer any quotation, invoice, cost or other account, book of accounts, voucher, receipt letter, memorandum, paper of writing or any copy of or extract from any such document and also furnish information and returns verified in such manner as may be required in any way relating to the execution of this contract or relevant for verifying or ascertaining cost of execution of this contract (the decision of the Engineer on the question of relevancy of any documents, information or return being final and binding on the parties.) The contractor shall similarly produce vouchers, etc., if required to prove to the Engineer, that materials supplied by him, are in accordance with the specification laid down in the contract.
- (ii) If any portion of the work in a contract of value more than one crore of rupees be carried out by a sub-contractor or any subsidiary or allied firm or company (as per Clause 7 of the General Conditions of Contract), the Engineer shall have power to secure the book of such sub-contractor any subsidiary or allied firm or company, through the contractor, and such book shall be open to his inspection.
- (iii) The obligations imposed by sub clause (i) and (ii) above is without prejudice to the obligations of the contractor under any statute, rules or orders binding on the contractor.

52. **Withholding and lien in respect of sums claimed** – Whenever any claim or claims for payment of a sum of money arises out of or under the contract against the contractor, the RailTel shall be entitled to withhold and also have a lien to retain such sum or sums in whole or in part from the security, if any, deposited by the contractor and for the purpose aforesaid, the RailTel shall be entitled to withhold the said security deposit or the security if any, furnished as the case may be and also have a lien over the same pending finalization or adjudication of any such claim. In the event of the security being insufficient to cover the claimed amount or amounts or if no security has been taken from the contractor, the RailTel shall be entitled to withhold and have a lien to the extent of the such claimed amount or amounts referred to supra from any sum or sums found payable or which at any time thereafter may become payable to the contractor under the same contract or any other contract with this or any other RailTel or any Department of the Central Government pending finalization or adjudication of any such claim.

It is an agreed term of the contract that the sum of money or moneys so with held or retained under the lien referred to above, by the RailTel will be kept withheld or retained as such by the RailTel till the claim arising out of or under the contract is determined by the arbitrator (if the Contract is covered by the arbitration clause) or by the competent court as the case may be and that the contractor will have no claim for interest or damages whatsoever on any account in respect of such withholding or retention under the lien referred to supra and duly notified as such to the contractor. For the purpose of this clause, where the contractor is a partnership firm or a limited company, the RailTel shall be entitled to withhold and also have a lien to retain to-words

such claimed amount or amounts in whole or in part from any sum found payable to any partner/limited company, as the case may be whether in his individual capacity or otherwise.

Lien in respect of claims in Other Contracts – Any sum of money due and payable to the contractor (Introducing the security deposit returnable to him) under the contract may be withheld or retained by way of lien by the RailTel, against any claim of this or any other RailTel or any other Department of the Central Government in respect of payment of a sum of money arising out of or under any other contract made by the contractor with this or any other Department of Central Government.

It is an agreed term of the contract that the sum of money so withheld or retained under this clause by the RailTel will be kept withheld or retained as such by the RailTel till the claim arising out of or under any other contract is either mutually settled or determined by arbitration, if the other contract is governed by arbitration clause or by the competent court as the case may be and contractor shall have no claim for interest or damages whatsoever on this account or on any other ground in respect of any sum of money withheld or retained under this clause and duly notified as such to the contractor.

53. **Signature on Receipts for Amounts** – Every receipt which may become payable or for any security which may become transferable to the Contractors under these presents, shall, if signed in the partnership name by any one of the partners of a Contractor's firm be a good and sufficient discharge to the RailTel in respect of the moneys or security purported to be acknowledged thereby and in the event of death of any of the Contractor partners during the pendency of the contract it is hereby expressly agreed that every receipt by any one of the surviving Contractor partners shall if so signed as aforesaid be good and sufficient discharge as aforesaid provided that nothing in this clause contained shall be deemed to prejudice or effect any claim which the RailTel may hereafter have against the legal representative of any contractor partner so dying, for or in respect of any breach of any of the conditions of the contract, provided also, that nothing in this clause contained shall be deemed to prejudice or effect the respective rights or obligations of the Contractor partners and of the legal representative of any deceased Contractor partner's interest.

54. **LABOUR**

Wages to Labour – The Contractor shall be responsible to ensure compliance with the provisions of the Minimum Wages Act, 1948 (hereinafter referred to as the "said Act") and the Rules made thereunder in respect of any employees directly or through petty contractors or sub-contractors employed by him on road construction or in building operations or in stone breaking or stone crushing for the purpose of carrying out this contract. If in compliance with the terms of the contract, the contractor supplied any labour to be used wholly or partly under the direct orders and control of the RailTels whether in connection with any work being executed by the contractor or otherwise for the purpose of the RailTel such labour shall, for the purpose of this clause, still be deemed to be person employed by the Contractor.

If any moneys shall as a result of any claim or any claim or application made under the said Act be directed to be paid by the RailTels, such moneys shall be deemed to be moneys payable to the RailTel by the Contractor and on failure by the Contractor to repay any moneys paid by it as aforesaid within seven days after the same shall have been demanded, the RailTel shall be

entitled to recover the same from any moneys due or accruing to the contractor under this or any other Contractor with the RailTels.

Apprentices Act – The Contractor shall be responsible to ensure compliance with the provisions of the Apprentices Act 1961 and the Rules and Orders issued thereunder from time to time in respect of apprentices directly through petty contractors or sub-contractors employed by him for purpose of carrying out the contract.

If the Contractor directly or through petty contractor or sub-contractors fails to do so, his failure will be a breach of the contract and the RailTel may, in its discretion, rescind the contract. The contractor shall also be liable for any pecuniary liability arising on account of any violation of the provisions of the Act.

55. **Provisions of Payments of Wages Act** – The Contractor shall comply with the provisions of

the Payment of Wages Act, 1936 and the rules made thereunder in respect of all employees directly or through petty contractors or sub-contractors employed by him in the works. If in compliance with the terms of the contract, the contractor directly or through petty contractors or sub-contractors shall supply any labour to be used wholly or partly under the direct orders and control of the Engineer whether in connection with the works to be executed hereunder or otherwise for the purpose of the Engineer such labour shall nevertheless be deemed to comprise persons employed by the contractor, and any moneys which may be ordered to be paid by the Engineer shall be deemed to be moneys payable by the Engineer on behalf of the contractor to repay such money to the RailTel deduct the same from any moneys due to the contractor in terms of the contract. The RailTel shall be entitled to deduct from any moneys due to the contractor (Whether under this contract or any other contract all moneys paid or payable by the RailTel by way of compensation of aforesaid or for costs of expenses in connection with any claim thereto and the decision of the Engineer upon any question arising out of the effect or force of this clause shall be final and binding upon the contractor.

Provision of Contract Labour (Regulation and Abolition) Act 1970

- (1) The Contractor shall comply with the provision of the Contract Labour (Regulation and Abolition) Act 1970 and the Contract Labour (Regulation and Abolition) Act, Central Rules 1971 as modified from time to time, whenever applicable and shall also indemnify the RailTel from and against any claims under the aforesaid Act and the Rules.
- (2) The Contractor shall obtain a valid licence under the aforesaid Act as modified from time to time before the commencement of the work and continue to have a valid licence until the completion of the work. Any failure to fulfill this requirement shall attract the penal provision of the Contract Labour Act in respect of non-execution of the work.
- (3) The Contractor shall pay to the labour employed by him directly or through sub-contractor the wages as per provisions of the aforesaid Act and the Rules wherever applicable. The Contractor shall notwithstanding the provisions of the contract to the contrary, cause to be paid the wages to labour indirectly engaged on the work including any engaged by his sub-contractors in connection with the said work, as if the labour had been immediately employed by him.
- (4) In respect of all labour directly or indirectly employed in the work for performance of the contractor's part of the contract the contractor shall comply with or cause to be complied with the provision of the aforesaid Act and the Rules wherever applicable.
- (5) In every case in which, by virtue of the provisions of the aforesaid Act or the Rules, the RailTel is obliged to pay any amount of wages to a workman employed by the contractor or his sub-contractor in execution of the work or to incur any expenditure in providing welfare and health amenities required to be provided under the aforesaid Act and the Rules or to incur any expenditure in providing welfare and health amenities required to be provided under the aforesaid Act or the Rules or to incur any expenditure on account of the contingent liability of the RailTel due to contractor's failure to fulfill his statutory obligations under the aforesaid Act or the Rules the RailTel will recover from the contractor, the amount of wages so paid or the amount of expenditure so incurred, and without prejudice to the rights of the RailTel under section 20, sub-section (2) and section 21 sub-section (4) of the aforesaid Act, the RailTel shall be at liberty to recover such amount or part thereof by deducting it from the security deposit and/or from any sum due by the RailTel to the contractor whether under the contract or otherwise. The RailTel shall not be bound to contest any claim made against it under sub-section (1) of section 20 and sub-section (4) of section 21 of the aforesaid Act except on the written request of the contractor and upon his giving to the RailTel full security for all costs for which the RailTel might become liable in contesting such claim. The decision of the RailTel regarding the amount actually recoverable from the contractor as stated above, shall be final and binding on the contractor.

56. **Reporting of Accidents to Labour** – The Contractor shall be responsible for the safety of all employees directly or through petty contractors or sub-contractors employed by him on the works and shall report serious accidents to any of them however and wherever occurring on the works to the Engineer

or the Engineer's Representative and shall make every arrangement to render all possible assistance.

57. **Provisions of Workmen's Compensation Act**—In every case in which by virtue of the provision of Section 12 sub-section (1) of the Workmen's Compensation Act, 1923, RailTel is obliged to pay compensation to a workman directly or through the petty Contractor employed by the Contractor or sub-contractor in executing the work, RailTel will recover from the contractor the amount of the compensation so paid, and, without prejudice to the right of RailTel under Section 12 sub-section (2) of the said Act. RailTel shall be at liberty to recover such amount or any part thereof by deducting it from the security deposit or from any sum due by RailTel to the Contractor whether under these conditions or otherwise, RailTel shall not be bound to contest any claim made against it under Section 12, sub-section (1) of the said Act except on the written request of the Contractor and upon his giving to RailTel full security for all costs for which RailTel might become liable in consequence of contesting such claim.

Provision of Mines Act – Deleted

58. RailTel not to provide quarters for Contractor – No quarters shall be provided by the RailTel for the accommodation of the contractor or any of his staff employed on the work.

59 **Labour camps:**

- (1) The Contractor shall at his own expense make adequate arrangements for the housing, supply of drinking water and provision of latrines and urinals for his staff and workman directly or through the petty contractors or sub-contractors and for temporary crèche (Bal-Mandir) where 50 or more women are employed at a time. Suitable sites on RailTel land, if available, may be allotted to the Contractor for the erection of labour camps either free of charge or on such terms and conditions that may be prescribed by the RailTel. All camp sites shall be maintained in clean and sanitary conditions by the Contractor at his own cost.
- (2) **Compliance to Rules for Employment of Labour** – The Contractor(s) shall conform to all laws, bye-laws, rules and regulations for the time being in force pertaining to the employment of local or imported labour and shall take all necessary precautions to ensure and preserve the health and safety of all staff employed directly or through petty Contractors or sub-contractors on the works.
- (3) **Preservation of Peace** – The Contractor shall take requisite precautions and use his best endeavors to prevent any riotous or unlawful behavior by or amongst his workmen and others employed directly or through petty contractor or sub-contractors on the works and preserve the health and safety of all staff employed directly or through petty Contractors or sub-contractor on the works.
- (4) **Sanitary Arrangement** – The contractor shall obey all sanitary rules and carry out all sanitary measures that may time to time be prescribed by the RailTel Medical Authority and permit inspection of all sanitary arrangements at all times by the Engineer, the Engineer's Representative or the Medical Staff of the RailTel. Should the Contractor fail to make adequate sanitary arrangements, these will be provided by the RailTel and the cost therefor recovered from the contractor.
- (5) **Outbreak of Infectious Disease** – The Contractor shall remove from his camp such labour and their families as refuse protective inoculation and vaccination when called upon to do so by the Engineer or the Engineer's Representative on the advice of the Railway/RailTel Medical Authority. Should Cholera, Plague or other infectious disease break out, the Contractor shall burn the huts, beddings, clothes and other belongings of or used by the infected parties and promptly erect new huts on healthy sites as required by the engineer, failing which within the time specified in the Engineer's requisition, the work may be done by the RailTel and the cost therefor recovered from the Contractor.
- (6) **Treatment of Contractor's staff in Railway Hospitals** – Deleted

- (7) **Medical facilities at site** – The contractor shall provide medical facilities at the site as may be prescribed by the engineer on the advice of the medical authority in relation to the strength of the contractor's resident staff, and workmen.
- (8) **Use of Intoxicants** – The sale of ardent spirits or other intoxicating beverages upon the work or in any of the buildings, encampments or tenements owned, occupied by or within the control of the Contractor or any of his employees shall be forbidden and the Contractor shall exercise his influence and authority to the utmost extent to secure strict compliance with this condition.
- (9) **Non-employment of Female Labour** – The contractor shall see that the employment of female labour in cantonment areas, particularly in the neighborhood of soldier's barracks, should be avoided as far as possible.
- 10) **Restrictions on the employment of retired Engineers of Railway services within two years of their Retirement** – The contractor shall not, if he is a retired government engineer of Gazetted rank, who has not completed two years from the date of retirement, in connection with his contract in any manner whatsoever without obtaining prior permission of the President and if the contractor is found to have contravened this provision, it will constitute a breach of contract and Administration will be entitled to terminate the contract of the contractor and forfeit his security deposit.

60. Non-Employment of Labourers below the age of 15

- (1) The Contractor shall not employ children below the age of 15 as labourers directly or through petty contractors or sub-contractors for the execution of work.
- (2) **Medical Certificate of Fitness for Labour** – It is agreed that the contractor shall not employ a person above 15 and below 19 years of age for the purpose of execution of work under this contract unless a medical certificate of fitness in the prescribed form granted to him by a certifying surgeon certifying that he is fit to work as an adult is obtained and kept in the custody of the contractor or a person nominated by him in this behalf and the person carries with him, while at work, a token giving a reference to such certificate. It is further agreed that the responsibility for having the adolescent examined medically at the time of appointment or periodically till he attains the age of 19 years shall devolve entirely on the contractor and all the expense to be incurred on this account shall be borne by him and no fee shall be charged from the adolescent or his parent for such medical examination.
- (3) **Period of Validity of Medical Fitness Certificate** – A certificate of fitness granted or renewed for the above said purposes shall be valid only for a period of one year at a time. The certifying surgeon shall revoke a certificate granted or renewed if in his opinion the holder of it is, no longer fit for work in the capacity stated therein. Where a certifying surgeon refuses to grant or renew a certificate or revoke a certificate, he shall, if so required by the person concerned, state his reasons in writing for doing so.
- (4) **Medical Re-examination of Labourer** – Where any official appointed in this behalf by the Ministry of Labour is of the opinion that any person employed in connection with the execution of any work under this contract in the age group 15-19 years is without a certificate of fitness or is having a certificate of fitness but no longer fit to work in the capacity stated in the certificate, he may serve on the Contractor, or on the person nominated by him in this regard, a notice requiring that such person shall be examined by a certifying surgeon and such person shall not, if the concerned official so directs, be employed or permitted to do any work under this contract unless he has been medically examined and certified that he has been granted a certificate of fitness or a fresh certificate or a fresh certificate of fitness, as the case may be.

61. DETERMINATION OF CONTRACT

61.1.1 **Right of RailTel to determine the contract:** The RailTel shall be entitled to determine and terminate the contract at any time, should in the RailTel's opinion, the cessation of work becomes necessary owing to paucity of funds or from any other cause whatever, in which case the value of approved materials at site and of work done to date by the Contractor will be paid for in full at the rate specified in the contract. Notice in writing from the RailTel of such determination and the reasons therefore shall be conclusive evidence thereof.

Payment on determination of contract: Should the contract be determined under sub-clause (1) of this clause and the Contractor claims payment for expenditure incurred by him in the expectation of completing the whole of the work, the RailTel shall admit and consider such claims as are deemed reasonable and are supported by vouchers to the satisfaction of the Engineer. The RailTel's decision on the necessity and propriety of such expenditure shall be final and conclusive.

The contractor shall have no claim to any payment of compensation or otherwise, howsoever on account of any profit or advantage which he might have derived from the execution of the work in full but which he did not derive in consequence of determination of contract.

62. TERMINATION OF CONTRACT OWING TO DEFAULT OF CONTRACTOR:

If the Contractor should:

- (i) Become bankrupt or insolvent, or
- (ii) Make an arrangement with or assignment in favour of his creditors, or
- (iii) Being a Company or Corporation, go into liquidation (other than voluntary liquidation for the purpose of amalgamation or reconstruction), or
- (iv) Have an execution levied on his goods or property on the works, or assign the contractor or any part thereof other than as provided in clause-21 of SCC, or
- (v) Abandon the contract, or
- (vi) Persistently disregard the instructions of the RailTel's Engineer with regard to work, or
- (vii) Contravene any provision of the contract, or
- (viii) Fail to adhere to the agreed programme of work by a margin of 10% of the Stipulated period, or
- (ix) Fail to remove materials from the site or to pull down and replace the work after receiving from the Engineer's notice to the effect that the said materials or works have been condemned or rejected, or
- (x) Fail to take steps to employ competent or additional staff and labour as required under clause 7 of SCC (Chapter 4 Section-I) or
- (xi) Fail to afford the Engineer or Engineer's representative proper facilities for inspecting the works or any part thereof as required under clause 28, or
- (xii) Promise or give any bribe, commission, gift or advantage either himself or through his partner, agent or servant to any officer or employee of RailTel or any person on his or on their behalf in relation to the execution of this or any other contract with the RailTel,
- (xiii) **A)** At any time after the tender relating to the contract has been signed and submitted by the contractor, being a partnership firm admit as one of its partners or employ under it or being an incorporated company elect or nominate or allow to act as one of its directors or employ under it in any capacity whatsoever any retired engineer of the gazetted rank or any other retired gazetted officer working before

his retirement, whether in the executive or administrative capacity, or whether holding any pensionable post or not, in the Engineering Department of the Railways for the time being owned and administered by the President of India before the expiry of two years from the date of retirement from the said service of such Engineer or Officer unless such Engineer or Officer has obtained permission from the President of India or any officer duly authorized by him in this behalf to become a partner or a director or to take employment under the contract as the case may be, or

B) Fail to give at time of submitting the said tender:-

- a) The correct information as to the date of retirement of such retired engineer or retired officer from the said service, or as to whether any such retired engineer or retired officer was under the employment of the contractor at the time of submitting the said tender, or
- a) the correct information as to such engineers or officers obtaining permission to take employment under the contractor, or
- b) being a partnership firm the correct information as to, whether any of its partners was such a retired engineer or retired officer, or
- c) being an incorporated company, the correct information as to, whether any of its directors was such a retired engineer or retired officer, or
- d) being such a retired engineer or retired officer suppress and not disclose at the time of submitting the said tender the fact of his being such a retired engineer or a retired officer or make at the time of submitting the said tender a wrong statement in relation to his obtaining permission to take the contract or if the contractor be a partnership firm or an incorporated company to be a partner or director of such firm or company as the case may be or to seek employment under the contractor.

Then and in any of these said clauses, the Engineer on behalf of the RailTel may serve the Contractor with a notice in writing to that effect and if the Contractor does not, within 7 days after the delivery to him of such notice, proceed to make good his default in so far as the same is capable of being made good and carry on the work or comply with such directions as aforesaid to the entire satisfaction of the Engineer, the RailTel shall be entitled after giving 48 hours notice in writing under the hand of the Engineer to rescind the contract as a whole or in part or parts (as may be specified in such notice) and adopt either or both the following courses: A final termination notice will be issued by RailTel after expiry of 48 hrs notice.

62.2 RIGHT OF RAILTEL AFTER TERMINATION OF CONTRACT OWING TO DEFAULT OF CONTRACTOR:

In the event of any or several of the courses, referred in clause 62.1 above, being adopted:

- (a) The Contractor shall have no claim to compensation for any loss sustained by him by reason of his having purchased or procured any materials or entered into any commitments or made any advances on account of or with a view to the execution of the works or the performance of the contract and Contractor shall not be entitled to recover or be paid any sum for any works thereon not actually performed under the contract, unless or until the Engineer shall have certified the performance of such work and the value payable in respect thereof and the Contractor shall only be entitled to be paid the value so certified.
- (b) The Engineer or Engineer's Representative shall be entitled to take possession of any materials, tools, implements, machinery or buildings on the works or on the property on which these are being or ought to have been executed, and to retain the employ the same in the further execution of the works or any part thereof until the completion of the works without the Contractor being entitled to any compensation for the use and employment thereof for wear and tear or destruction thereof.
- (c) The Engineer shall, as soon as may be practicable after removal of the Contractor fix and determine

expert or by or after reference to the parties or after such investigation or enquiries as he may consider fit to make or institute and shall certify what amount (if any) has at the time of termination of the

contract been reasonably earned by or would reasonably accrue to the Contractor in respect of the work then actually done by him under the contract what was the value of any unused or partially used materials, any constructional plants and any temporary works upon the site. The legitimate amount due to the contractor after making necessary deductions and certified by the Engineers should be released expeditiously.

63. Matters finally determined by the RailTel: All disputes and differences of any kind whatsoever arising out of or in connection with the contract, whether during the progress of the work or after its completion and whether before or after the determination of the contract shall be referred by the contractor to the RailTel and the RailTel shall within 120 days receipt of the Contractor's representation make and notify decisions on all matters referred to by the contractor in writing provided that matters for which provision has been made in clause 8, 18, 22.5, 29, 43.2, 45(a), 55, 55.1(5), 57, 61.1, 61.2 and 62.1 of General Condition of Contract or in any clause of the Special Conditions of the Contract shall be deemed as 'excepted matters' and decisions of the RailTel's authority, thereon shall be final and binding on the contractor provided further that 'excepted matters' shall stand specifically excluded from the purview of the arbitration clause and not be referred to arbitration.

64. SETTLEMENT OF DISPUTE AND ARBITRATION

64.1 With Private Parties

Any dispute or difference whatsoever arising between the parties out of or relating to the construction, meaning, scope, operation or effect of this contract or the validity or the breach thereof shall be settled by a sole arbitrator in accordance with provisions contained in Arbitration and Conciliation Act, 1996 as amended and the award made in pursuance thereof shall be binding on the parties. The venue of such arbitration or proceeding thereof shall be New Delhi.

All arbitration proceedings shall be conducted in English. Resources against any Arbitral award so rendered may be entered into court having jurisdiction or application may be made to such court for the order of enforcement as the case may be.

The Arbitral Tribunal shall consist of the sole Arbitrator if the value of claim is upto Rs. 10 lakhs. The arbitrator will be by the Managing Director of RailTel Corporation of India Limited. If the value of claim or amount under dispute is more than Rs. 10 lakhs, the matter shall be referred to the adjudication of arbitral council. Managing Director/ RailTel shall furnish a panel of three names to the contractor, out of which contractor will recommend one name to be his nominee and then Managing Director /RailTel shall appoint out of the panel one name as RailTel's nominee and these two arbitrators with mutual consent appoint a third arbitrator who shall act as deciding arbitrator. The award of the Sole arbitrator or the Arbitral council, as the case may be, shall be final and binding on both the parties, i.e. Contractor and RailTel.

Each of the parties agree that notwithstanding that the matter may be referred to Arbitrator as provided herein, the parties shall nevertheless pending the resolution of the controversy or disagreement continue to fulfil their obligation under this Agreement so far as they are reasonably able to do so.

64.2 With CPSE/Govt. Department/Govt. Organisation

In the event of any dispute or difference relating to the interpretation and application of the provisions of the contracts, such dispute or difference shall be referred by either party for Arbitration to the sole Arbitrator in the Department of Public Enterprises to be nominated by the Secretary to the Government of India in-charge of the Department of Public Enterprises. The Arbitration and Conciliation Act, 1996 shall not be applicable to arbitration under this clause. The award of the Arbitrator shall be binding upon the parties to the dispute, provided, however, any party aggrieved by such award may make a

further reference for setting aside or revision of the award to the Law Secretary, Department of Legal Affairs, Ministry of Law & Justice, Government of India. Upon such reference the dispute shall be decided by the Law Secretary or the Special Secretary/Additional Secretary when so authorized by the Law Secretary, whose decision shall bind the Parties finally and conclusively. The Parties to the dispute will share equally the cost of arbitration as intimated by the Arbitrator.



VOLUME – III

TECHNICAL SPECIFICATIONS OF CONTRACT



रेलटेल
RAILTEL

SPECIFICATIONS :

4.1 Standard Specifications for Materials and Works

Separate Annexure containing Standard Specifications for Materials and Works in Volume-1(Civil) and Volume – II (Electrical) are enclosed in tender documents..

It is presumed that bidders have gone through the Standard Specifications for Materials and works (Civil,) and Volume-II (Electrical) including latest correction slips issued up to date i.e day prior to the deadline for submission of bids before quoting the rates. Works are to be executed as per above referred specifications as specified below :-

4.2 TECHNICAL SPECIFICATION FOR CONSTRUCTION OF 9 nos. Gate Goomty

These specifications shall be applicable to 9 nos. Gate Goomty building. of various types to be constructed along the project length.

4.2.1 Technical Specifications common to all type of buildings :

4.2.1.1 Technical specifications for various activities involved in the work shall generally be in accordance with attached standard specification for material and works as amended upto date. In case specification for any activity necessary for completion of building is not available in Standard Specifications, RCIL specification, relevant BIS codes of practices shall be applicable in that order. In case of any contradicting instructions in the specifications, Engineer's decision will be final and binding.

4.2.1.2 General Arrangement Drawings of Gate Goomty to be provided by RCIL in the bidding documents.

4.2.1.3 Suitable economical structural and architectural design for foundation and super structure consisting of masonry walls, reinforced columns/beams/slabs shall be done by the Contractor as per site conditions for the service building and others structures including all detailed designs of RCC works i.e. columns, beams stair case, balcony, slabs etc. keeping in view the relevant structural design & making the building earthquake resistant Working drawings will have to be prepared by the contractor for each activity of work, giving details of reinforcement, water arrangements, drainage, sewerage, floorings, fittings etc. and got approved from the Engineer. The construction will be done with approved drawings.

4.2.1.4 The rates for construction of building includes cost of all materials, labour, tools & plants, equipments, taxes, ascent, descent, lead and lift etc., nothing will be paid extra and buildings have to handed over complete in all respect to house the signalling/ Electrical/Operating equipments and machinices including provision of ducts, trenches, ramps etc. complete in all respect required to make it functional. This also includes cost of all architectural features.

4.2.1.5 If any activity of the work is essential for completion of the building but is not mentioned specifically in these specifications or elsewhere in the bidding documents, the same shall be deemed to be included in the rates and shall be executed by the Contractor as per specifications decided by the Engineer and the building shall be handed over in functional manner, complete in all respects.

4.2.1.6 Water & electricity shall be arranged by the Contractor at his own cost for execution of works.

4.2.1.7 Contractor has to make arrangements for approach to site, stacking of materials and all temporary works necessary for the execution of work at his own cost.

4.2.1.8 Contractor will have to make arrangement for required tests for testing the soundness of the work including required lab test for the materials i.e cement, sand, aggregate, steel, bricks etc including cube test for the concrete at contractor's own cost. As directed by the Engineer.

4.2.1.9 Sampling and testing of work/material at site/laboratory shall be as per the Railways Specification and relevant Indian Standard Specifications, with up to date corrections.

4.2.1.10 If any work is found unsatisfactory or under specification the same will have to be redone by the Contractor at Contractor's own cost. In case, the Contractor fails to do so, the same will be got done by Engineer at the Contractor's cost.

4.2.1.11 The Engineer will be at liberty to get any work or material dismantled/removed by any other means at Contractor's cost if it is found unsatisfactory or under specification, and the contractor fails to rectify the same within specified time.

4.2.1.12 The site shall be cleared of all debris etc. before commissioning of work.

4.2.1.13 The contractor shall take all necessary safety precautions during fabrication, launching, of members, casting of RCC slabs etc. He shall also ensure safety of railway track if the work is required to be done near the track or above railway tracks.

4.2.1.14 In case there is any damage to road, drain or other structure during construction of the work by the contractor, the damages will have to be rectified by the contractor at his own cost.

4.2.1.15 Earth work: Earthwork in filling in plinth and floors including for plinth protection, if required shall be done by contractor, earth of good quality. No earth is to be taken from the railway premise except surplus from the excavation for the building.

4.2.1.16 Concrete work: All plain and reinforced concrete work to be done as per IS: 456 Code of Practice. Design mix concrete as approved by Engineer shall only be used. Nominal mix can be permitted by the Engineer only in exceptional circumstances. The cement concrete flooring, roof and other RCC/Concrete structures are to be leveled and compacted with vibrator of suitable size and specification.

4.2.1.17 Anti-termite treatment: Anti-termite treatment shall be provided as per CPWD/Railways Specifications, and shall be paid under relevant item of BOQ. The chemical shall be approved by the Engineer and used as per the manufacturer's instructions/ specifications.

4.2.1.18 Plinth protection – If not mentioned otherwise in the detailed drawings, plinth protection of one meter width all around the building shall be provided as per Railway Standard Specifications for materials & works.

4.2.1.19 Damp Proof Course (DPC) – Unless otherwise mentioned in the drawings, DPC will consist of 40mm thick 1:2:4 PCC with two coats of bitumen over it.

1.2.1.20 Masonry work – Masonry work has to be in well burnt clay bricks of class-I for external walls/fly ash brick which are neither plastered nor rendered on the outer face, free standing walls and parapets, as approved by the Engineer. All outer and load bearing walls shall be of minimum 230 mm thickness or more as per design, in cement mortar 1:6, all partition walls shall be 115

mm thick in cement mortar 1:4. Fly ash bricks or cement concrete blocks (hollow/ solid) conforming to the BIS can be used against relevant items .

4.2.1.21 Plaster: 12-15 mm thick in cement mortar 1:6 on all outer and inner walls except in ceiling. Inner walls shall be finally finished with POP. Underside of the slabs shall be rendered smooth wherever required and finished with POP. If for any type of building plaster have been stipulated different as compared to foregoing, the foregoing provision shall stand replaced.

4.2.1.22 Painting – Two coats of synthetic enamel paint of 1st quality over a priming coat of Asian, Berger, Nerolac or equivalent brand and shade as approved by the Engineer, on all exposed steel and wooden surfaces.

4.2.1.23 **Sanitary fittings/sewerage system:**

4.2.1.23.1 Manholes and junction chambers to be constructed by Contractor as per the design by the Contractor & approved by the Engineer and to be connected with RCC pipes of 150/200 mm dia. with each other and to septic tank or to existing sewerage arrangement (up to 15m from extreme outer wall of building in the direction of source to be connected, including obtaining necessary clearance from concerned authorities required for the same. In case sewerage system is not to be connected to trunk sewer as stipulated, contractor will furnish appropriate design of septic tank to be approved by Engineer and will construct the septic tank accordingly.

4.2.1.23.2 Rain water pipes: Adequate number of rain water pipes of min 100 mm dia, PVC of approved quality and make as approved by the Engineer to be provided. Inlet of the rain water pipe to be provided with shoe and CI gratings and at the outlets necessary protection to be done to prevent erosion of soil.

4.2.1.23.3 Soil and vent pipes: PVC pipes of min 100 mm dia to be provided for soil and vent pipes including all branches of required degree, access door and other accessories as necessary for laying the pipes of approved quality and make as approved by the Engineer to be provided. Before embedding the pipes under the floor the same will have to be tested against any leakage. Necessary floor traps, gully traps as essential will be provided. Storm water drain of suitable size to be provided as approved by the Engineer.

4.2.1.23.4 Wash Basins and Sink: Wash basins (Ceramic) of approved make and size, colour as per N.Rly CE circular and make to be provided in ladies and gents toilet with shelf, looking glass and towel rails (CP Brass). Urinals/ Squatting pans (ceramic) of approved size and make to be provided with ceramic flushing systems as per requirement. Stainless steel/Ceramic sinks of approved size and makes to be provided in battery rooms,. All water services and sinks will be connected through bottle traps to concealed outlet pipe.

4.2.1.24 Water supply: Necessary layout for water supply distribution in the toilets & baths to be designed by the Contractor and submitted for approval of Engineer and to be connected with GI pipe of designed dia to the existing main water line (up to 15m from extreme outer wall of building in the direction of source to be connected, including obtaining necessary clearance from concerned authorities required for the same. All internal pipes will be laid concealed in walls and tested for leakages for minimum 12m head of water. All necessary taps, stop valve etc. of approved size and make to be provided by Contractor to make the toilets functional including provision of water tank of designed capacity Moulded Polyethylene overhead tank Sintax make or equivalent in accordance with IS 127012 – 1996. This will include provision of float valve, copper/ brass rod and plastic ball with inlet, outlet, overflow, washout connections etc. for the overhead tank complete in all respect. Taps in platform toilets will be self-closing type.

4.2.1.25 Water proofing and heat insulation of roofs: Roof shall be painted with two coats of bitumen as per Railway Standard Specifications for materials and works followed by mud phuska terracing with tile brick paving as per Railway standard specification for material and works.

4.2.1.26 Drip courses- Drip course of approved design has to be provided all around the building, chajjas etc.

4.2.2 Technical Specifications Specific to Gate Goomty:

4.2.2.1 Interior finish – Two coats of 1st quality oil bound distemper of approved shade over POP coating to make the surface smooth. 3rd coat may be done before handing over of assets.

4.2.2.2 Exterior finish – Two coats of 1st quality cement paint of approved shade over POP coating to make the surface smooth. 3rd coat shall be done before handing over of assets.

4.2.2.3 Flooring:

4.2.2.3.1 Deleted

4.2.2.3.2 Deleted

4.2.2.3.3 Small Stair: Chequered tile flooring over 20mm (average) thick base laid over and jointed with grey cement slurry mixed with pigment to match the shade of the slab.

4.2.2.3.4 Verandah Flooring & Ground Floor Passage: 1st quality Vitrified tiles(600 x 600mm) flooring over average 20 mm thick base of cement and sand mortar 1:4 and jointed with grey cement slurry mixed with pigment to match the shade of stone slab, including rubbing and polishing complete over 100 mm thick CC 1:4:8 over 100 mm thick sand filling on well rammed and consolidated earth filling.

4.2.2.3.5 Toilets - Finished floor to be kept 25 mm below the normal floor of the building. Ceramic tiles of Group B-II Clause 5.1 (for abrasion resistance) of IS:15622 (Ceramic Floor Tiles) of size 400mmx400mm and above of Kajaria, Nitco or similar make and shade and approved by Engineer laid over 20 mm thick bed of cement and sand mortar 1:4 with neat cement slurry mixed with pigment to match the shade of tiles between joints and over the base in floors laid over 100 mm thick CC 1:4:8 over 100 mm thick sand filling on well rammed and consolidated earth filling on ground floor. On subsequent floors the tiles will be laid directly on mortar bed. Ceramic Wall Tiles of size 300x450 mm and above of 1st quality conforming to Group B-III (Ceramic Wall Tiles) of IS:15622 of Kajaria, Nitco or similar make, quality and shade as approved by the Engineer to be provided on walls for full height up to ceilings over 13 mm thick cement mortar 1:3. All the tiles to be laid with zero gaps between them.

4.2.2.3.6 Deleted

4.2.2.4 Door Frames: The door frame shall be of MS TEE/Angle 40mmx40mmx6mm.

4.2.2.4.1 Door Shutters: 32 mm thick flush door shutter, commercial type thermosetting, synthetic resin bound core of block board construction with lipping of 1st class commercial quality timber, such as elm or its equivalent, battens on all edges and well matched commercial ply veneering with vertical grains on both faces of shutters. Veneer and board shall be as per BIS specifications with brass fittings of approved size and make as per requirement.

4.2.2.4.2 Windows/Ventilators: Steel windows of steel as approved by the Engineer. Glass panes 4 mm thick with glazing clips and special metal sash putty, of approved make with iron fittings of approved size and make as per requirement.

4.2.2.4.3 Deleted

4.2.2.4.4 MS grill of approved design shall be provided in the windows and ventilators.

4.2.2.4.5 Necessary exhaust fan opening to be provided as required.

4.2.2.4.6 Deleted

4.2.3 Technical specifications specific to Station Buildings: Any building which is part of the main station building shall be constructed with the under mentioned technical specifications.

4.2.3.1 Deleted

4.2.3.2 Deleted

4.2.3.3 Deleted

4.2.3.4 Deleted

4.2.3.5 Door fittings: Deleted

4.2.3.6 Interior finish: Deleted

(i) Plaster: Deleted.

(ii) Painting: Deleted

4.2.3.7 Exterior finish – Deleted

Plaster : Deleted.

Painting: Deleted

4.2.3.8 Flooring and Dado: Deleted

4.2.3.8.1 Deleted

4.2.3.8.2 Stair: Deleted

4.2.3.8.3 Toilets: Deleted

4.2.3.9 Booking Counter: Deleted

4.2.3.9.1 Deleted

4.2.3.9.2 Deleted

ANNEXURE- REWIRING / WIRING AND ARTHING

**NORTHERN RAILWAY
TECHNICAL
SPECIFICATIONS**

1.0 TECHNICAL SPECIFICATIONS FOR REWIRING / WIRING AND EARTHING:

1.1All wiring work shall be done as per ISS/IE rules.

1.2Point wiring includes supply and providing of modular switches.

1.3 On completion of wiring, the following tests conf. to the relevant ISS/E rules shall be carried etc.

1) Insulation resistance test.

2) Polarity test of switches.

3) Earth continuity test.

4) Earth resistance test.

1.4 The conduit pipe with accessories shall be fixed/ provided in steel trusses/ angle iron/ wall by means by suitable MS clumping arrangement as per site requirement and ISS/IE rules.

1.5 The power and lighting wiring, as the case may be shall be kept separate & distinct each other.

2. EARTHING SYSTEM:-**2.1 PIPE EARTHING:**

1) The earthing electrode shall be made of G.I. pipe of 50mm dia medium class (class B) conforming to relevant ISI

4.5 meter long tapered at the bottom holes of 12 mm dia drilled not less 75 mm from each other upto 2 meters of length from the bottom.

2) The pipe electrode shall be buried in the ground vertically with its top nearly 200mm below from the top of enclosure.

3) A flange shall be provided on top of this pipe for watering the earth. This whole arrangement shall be housed in the masonry enclosure made of cement ratio 1:4:8.

4) Size of earthing lead shall be 6SWG GI wire connected the electrode with electric equipment.

2.2 MASONRY ENCLOSURE:

The top of pipe electrode shall be housed in a masonry enclosure of not less than 40CMx40CMx30CM (inner size) and 10CM thick. The pipe shall be buried in the ground vertically with its top nearly 20CM below top of enclosures. The covers of masonry for electrode shall be hinged type made of MS/ CI/RCC with proper arrangement for locking.

2.3 COMMON LOCATION FOR EARTH ELECTRODE: -

Normally one earth electrode shall not be situated less than 1.5 meter from any building. Care shall be taken that the excavation for the earth electrode may not affect the column footings of foundation of the building. In such case electrode may be located further away from building. The location of earth shall be such where the soil and reasonable changes of remaining moist as far as possible, entrance, pavements. Roads should definitely be avoided for location of earth electrode. The location of earth electrodes shall be fixed in consultation with Railway Authority.

2.4 ARTIFICIAL TREATMENT OF SOIL:

In case there is no option of site for earth electrode the earth resistance shall be reduced by the artificial treatment of the soil. For this purpose the most commonly used substances are Sodium Chloride (common salt) mixed with soft bake of charcoal in suitable proportion when this treatment is resisted to the electrode shall be surrounded by the mixture of the other /coal / coal and salt.

2.5 PROTECTION OF EARHTING LEAD: -

The earthing lead onwards shall be suitably protected from the mechanical injury by a 15mm dia GI pipe in case of GI wire portion of this protection pipe within ground shall be buried at least. 30 cm deep (to be increased to 60cm incase of road crossing and payments. The portion within the building shall be recessed in wall and floors to adequate depth (para-1.69 of CPWD general specification for electrical works Part-I internal 1972).

2.6 RESISTANCE OF EARTH ELECTRODE: -

No earth electrode shall have greater Ohm resistance than 2 Ohms. Every individual earth electrode shall be allotted serial number and earth Platte of size 20x22x3 mm of sheet steel pointed blank fixed a conspicuous position near the earth. The following information shall be written white or yellow paint on the earth plate.

- a) Earth No. _____.
- b) Individual earth resistance _____ Ohms
- c) Overall earth resistance _____ Ohms
- d) Date of test _____

The following test shall be carried out before the installation is put into commission.

- a) Earth resistance test.
- b) Earth continuity test.
- c) Insulation resistance test.
- d) Polarity test.

ANNEXURE- LAYING OF CABLE**SPECIFICATION FOR LAYING OF CABLE:- Deleted**

1. METHOD OF LAYING OF CABLES: Deleted
2. LAYING DIRECTLY IN GROUND : Deleted
3. PROVISION OF TRENCHES : Deleted.
4. EXCAVATION OF TRENCH: - Deleted
5. LAYING OF CABLE IN TRENCHES: - Deleted
6. FINAL PROTECTION: - Deleted
7. BACK FILLING OF TRENCHES: - Deleted
8. ROUTE MARKETS: - Deleted
9. CABLE IDENTIFICATION TAG: - Deleted
10. LAYING OF CABLES IN PIPES/CLOSED DUCTS: - Deleted
11. LAYING OF CABLES OPEN DUCTS: - Deleted
12. LAYING ON SURFACE: - Deleted
13. LAYING ON MS LADDER TRAY: - Deleted

EXPLANATORY NOTES FOR ELECTRICAL GENERAL SERVICES WORKS. GENERAL

These explanatory notes are for guidance of field staff. Each work has its own particular requirements. Engineer-in-charge will be responsible for successful execution of work as per technical specifications.

- i. All electrical works should comply with Indian Electricity Act 2003 and Indian Electricity Rules 1956.
- ii. All electrical installations works shall conform to relevant Indian Standard Code of Practice and carried out as per relevant safety Code of Practices, Guide for Safety Procedures in Electrical Work as per I.S. 5216/Pt.I & II/1982 shall be observed.
- iii. All components used in installation shall be of appropriate ratings of voltage, current and frequency.
- iv. All minor items viz. hardware items, foundation bolts, termination lugs for electrical connections etc. as required and necessary for proper working of the equipment shall be deemed to have been included in the tender, whether such items are specifically mentioned in the tender documents or not.
- v. The work shall be carried out under the supervision of the Railway Engineer.
- vi. The tenderer must inspect the site thoroughly before quoting rates, later on no claim shall be accepted in connection with inspection of site.
- vii. The cost of HT/LT Cable consumed during testing shall be borne by the Works Contractor.

Explanatory Notes

LED tube light system wattage 18 Watt to 20 Watt & 9 Watt LED bulb:-

All these items shall be supplied & commissioned as per CEE/N.Rly. Specification No.CEE/NR/121-Elect/PS/2018(Rev '3') Dated 28.06.2018 & CEE/NR/121- Elect/PS/2019 (Rev.4) dated 04.11.2019 or latest with correction dt.10.02.2020 or latest, respectively as per attached specification The work also includes wiring with 2x2.5 sq.mmPVC insulated multi stranded FRLS copper conductor cable, for connection from ceiling rose to fitting.

45 W LED Street light fitting:-

All these items shall be supplied & commissioned as per CEE/N.Rly. Specification No. CEE/NR/121-Elect/PS/2018(Rev '3') Dated 28.06.2018 & CEE/NR/121- Elect/PS/2019 (Rev.4) dated 04.11.2019 or latest latest with correction dt.10.02.2020 or latest respectively as per attached specification which are attached here as LED specification The work for all items also includes wiring with 2x2.5 sq.mm PVC insulated multi stranded FRLS copper conductor cable, for connection from junction box to fitting.

GI pipe bracket:-

GI pipe B class shall conform to relevant IS and approved make (Wight of GI pipe should be minimum 3.61 Kg permeter). Shape of bracket and fixing clamp shall be approved by Railways as per required at site and 40x5 size GIstrip with nut bolts & washer conforming to relevant IS should be used.

25A motor starter:-

The work includes supply of 25A Motor Starter (2M) as per Havells (Coral model)/Anchor (Roma)/Cona (Status)
.The material of motor starter should be Poly Carbonate & installation on flush type GI sheet metal & plate.

Ceiling fan shall be installed in conformity with IS 732/1989(Latesy Version),IS 4648/1968(LatestVersion).

Installation Of Exhaust Fan

The Exhaust Fan shall be fixed by grouting of 3/8" dia MS nut & bolt with washers/MS Fasteners of suitable size Installation shall be in conformity with IS 732/1989 or latest version, IS 4648/1968 or latest version.

Wiring for Light & Fan point (SP,MP,LP,ELP :-

These items shall be executed as per attached specification Annexure REWIRING / WIRING AND EARTHING. Wiring for light & fan point to be done through 2x1.5 Sq.mm FRLS PVC insulated multi stranded copper conductor s/core cable.

Modular Type switch 5A

Accessories shall be provided in conformity with IS 732/1989 (Latest Version), IS 4648/1968 (Latest Version).

Wiring for sub-main with 2x2.5 Sq mm FRLS PVC insulated multi stranded copper conductors/core cable:-

The work involved wiring for sub-main 2x2.5 Sq.mm FRLS PVC insulated multi stranded copper conductors/core cable in the recessed PVC conduit pipe 25 mm dia as required.

Wiring for sub-main with 2x4Sq mm PVC insulated multistranded copper conductor s/core cable:- The work involved wiring for sub-main 2x4.0 Sq.mm FRLS PVC insulated multi stranded copper conductors/core cable in the recessed PVC conduit pipe 25 mm dia as required.

Bakelite Ceiling Rose

Ceiling rose shall conform to IS 371/1979 (Latest Version). Ceiling rose shall be provided in conformity with IS 732/1989 (Latest Version), IS 4648/1968 (Latest Version).

PVC conduit pipe 25 mm dia:-

Rigid PVC conduit pipe shall conform to IS 9537/Pt.III/1983 (Latest Version) and accessories shall conform to IS 3419/1988(Latest Version).Laying of conduit shall be in conformity with IS 732/1989 (Latest Version), IS 4648/1968(Latest Version). The work also includes provision of MS boxes as per requirement at site.

L.T. SWITCH BOARD

1.0 SCOPE OF WORK

Medium voltage switch board cubicle type shall be suitable for three Phase, four wire, 415 V. 50 Hz AC solidly earthed neutral, electric supply system complete with accessories, Interconnections, continuous Glearth strip, bus bar chamber with copper bus bar, all instruments, energy meters, switchgears etc. in position duly wired up with copper conductor cable with colour coding, code numbering etc. and other accessories though not mentioned here but necessary to complete supply in all respects.

2.0 SCHEDULE OF REQUIREMENT

As per Schedule of Rate and Quantities.

3.0 PARTICULARS OF ELECTRIC SUPPLY SYSTEM

Three phase, four wires 415V, 50 Hz AC solidly earthed neutral system.

4.0 TYPE OF SWITCH BOARD

Switchboard shall be cubicle type metal clad free standing, floor mounted, dust and vermin proof, of uniform height and of multi-tier construction so as to occupy minimum floor area. Switchboard shall be extendable on both sides.

5.0 DETAILS OF CONSTRUCTIONAL FEATURE OF SWITCH BOARD

5.1 Switch board shall be manufactured with CRCA sheet of 14 Gauge and MS base channel of size 100x50x7.5 mm. Switchboard shall consist of a totally shrouded bus bar

chamber with screwed covers (screws should remain with covers when covers are removed for maintenance) and have ventilation jali duly protected from vermin. Bus bar and droppers should be suitably mounted on DMC insulators. Bus bars and droppers should be of high conductivity electrolytic copper suitable for electrical purpose and liberally designed of uniform cross section having a rating of bus bars as per mentioned in schedule of rate & quantities.

(Basis of bus bar cross section will be maximum of 1000 A./sq. In.). Bus bars shall be suitably insulated with heat shrinkable sleeves/epoxy coating to withstand the test voltage of 2.5 kV and have colour coding for identification of phases and neutral.

5.2 Bus Bar shall be provided in bus bar chambers throughout its entire length. Suitable rubber gaskets shall be provided between all openings and joints to make panel dust and vermin proof, absolutely.

5.3 Each incoming and outgoing panel shall be provided with glands in detachable plate and lugs and having entry from bottom.

5.4 Height of panel shall not be more than 2300 mm and operating height shall be between 250 to 1900 mm. Continuous GI earth bus bar shall be run of size not less than 50x6mm.

5.5 Switchboards shall be dead front, front operated, dust, vermin proof, extensible, top/bottom cable entry, compartmentalized made of CRCA sheet steel of thickness 2.0 mm non-load bearing, load bearing members & rigid supports for components and with lockable hinged doors. Joints of any kind in sheet metal shall be seam welded and all welding slag ground off and welding pits wiped smooth with plumber metal. All holes in metalwork shall be protected by substantial grommets or bushes to protect wiring passing through them. Maximum overall height of panels and maximum/minimum height of operating handles from floor level shall be as per standard norms.

5.6 Each Circuit Breaker shall be housed in a separate compartment enclosed on all sides. Circuit Breaker cradle shall be designed and constructed to permit smooth withdrawal and insertion. Movement shall be free of jerks, easy to operate and positive.

5.7 Enclosure shall comply with IS: 13947 Part-I 1993. All adjoining units, doors and covers shall be fully Neoprene gasketed unless specified/approved otherwise and equipped with integral lock. Enclosure protection shall be not less than IP 43.

5.8 Switchboard shall be designed for Incoming and Outgoing LV feeders as per provisions of IS: 8623 (Part I)–1993, IS 13947:1993 and IEC Pub 947-5-1 to latest version. Generous space shall be provided for vertical rising cables, their bending and termination.

5.9 Separate cable compartments running height of the Switch Board in case of front access Boards provided for incoming and outgoing cables.

Cable compartments of adequate size for easy termination of all incoming and outgoing cables entering from bottom.

5.10 All wiring for meters and other associated equipments shall be with FRLS, PVC insulated, stranded copper conductor wires. Minimum size of copper conductor control wires for switch-boards shall be 1.5 mm².

NOTE:

- i. Bus bars are to be provided in sections as per requirement for feeding essential & non-essential load as per drawing approved by Railways. All Incoming and Outgoing cable should be suitably earthed with cable glands, earthing studs, cable marking sleeves & Wago type connector of suitable ratings should be used for internal connections.
- ii. Quantities & capacities of MCCBs and capacity of copper Bus Bars should be considered as mentioned in Schedule.

Switchboard shall comprise of:

(A) INCOMING MCCB PANEL 400 AMP. 4POLE

Moulded Case Circuit Breaker 400 Amps. with CTR 400/5A 4 Pole, 35 KA Breaking Capacity, thermal magnetic release with adjustable over load & short circuit protection conforming to IS 13947/Pt.II/1993 (Latest Version). Rated short circuit breaking capacity (Ics= Icu) should not be less than 35 KA rms at 415 Volt 50 Hz AC. The MCCBs shall have spreader links and barriers as standard feature of manufacturer.

(B) OUTGOING MCCB PANEL 250 AMP. 4POLE

Moulded Case Circuit Breaker 250 Amps. with CTR 250/5A 4 Pole, 35 KA Breaking Capacity, thermal magnetic release with adjustable over load & short circuit protection conforming to IS 13947/Pt.II/1993 (Latest Version). Rated short circuit breaking capacity (Ics= Icu) should not be less than 35 KA rms at 415 Volt 50 Hz AC. The MCCBs shall have spreader links and barriers as standard feature of manufacturer.

(C) OUTGOING MCCB PANEL 125 AMP. 4POLE

Moulded Case Circuit Breaker 125Amps. with CTR 125/5A 4 Pole, 35 KA Breaking Capacity, thermal magnetic release with adjustable over load & short circuit protection conforming to IS 13947/Pt.II/1993 (Latest Version). Rated short circuit breaking capacity (Ics= Icu) should not be less than 35 KA rms at 415 Volt 50 Hz AC. The MCCBs shall have spreader links and barriers as standard feature of manufacturer.

(D) OUTGOING MCCB PANEL 63 AMP. 4POLE

Moulded Case Circuit Breaker 63Amps. with CTR 63/5A 4 Pole, 35 KA Breaking Capacity, thermal magnetic release with adjustable over load & short circuit protection conforming to IS 13947/Pt.II/1993 (Latest Version). Rated short circuit breaking capacity (Ics= Icu) should not be less than 35 KA rms at 415 Volt 50 Hz AC. The MCCBs shall have spreader links and barriers as standard feature of manufacturer.

(E) The Panel shall be complete with 400 Amp. Copper bus bars for Phases and 200 Amp. For Neutral to be provided.

Note:

- i. Incoming from Bus-Bar to outgoing ACB/MCCB/FSU/SFU shall be connected with suitable size copper BusBar and outgoing terminals of each MCCB/FSU/SFU shall be provided with suitable copper connectors so as to avoid direct cable connection with MCCB/FSU/SFU terminal. Above MCCB cover and case shall be made of high strength heat resisting and flame retardant thermosetting insulating material. Operating handle shall be quick make/break, trip-free type having suitable ON, OFF and TRIPPED indicators and a common handle for simultaneous operation of all phases. Suitable arc extinguishing device shall be provided for each contact. Tripping unit shall be connected by a common trip bar such that tripping of any one pole causes three poles to open simultaneously. Contact tips shall be made of suitable arc resistant alloy. Terminals shall be with adequate clearances.
 - a. MCCBs shall be provided with following interlocking devices with the compartment door.
 - b. Door interlock to prevent door being opened when the breaker is in ON position (extendable rotary handle to be invariable provided).
 - ii. Interlock to prevent the breaker being switch ON with the door open.
 - iii. MCCBs shall have trip free mechanism such that tripping command always overrides the closing command. MCCBs shall have disconnection capability to ensure that handle does not return to off position in case of contacts getting welded. Compartment doors shall clearly indicate the state of MCCB i.e. ON/OFF/TRIP MCCBs shall be provided with test function (push button or equivalent) to check the correct functionality of the MCCBs.
 - iv. Each MCCB shall have a facility for padlocking in the off position.
 - v. MCCBs shall have shrouded terminals.
 - vi. MCCBs shall not have any load line biasing.
 - vii. All releases shall be tamper proof
 - viii. The mechanical operations of MCCBs shall be \geq 15000 operations.
 - ix. Incoming and outgoing feeder name shall be displayed on Panel by screen printing.
 - x. MCCB shall be 10 KA Breaking Capacity 'C' Series and conforming to IS 8828/1996 (Latest Version)

- (E) Flush mounted electronic intelligent panel Meter on each incoming panel, for measuring voltage, current, KWH, PF, KW etc having class I accuracy, should be provided. Digital Ammeter should be provided on each Outgoing panel. On/Off LED indication light to be provided on each incoming & outgoing feeder. R/Y/B LED indication light to be provided on each incoming feeder.
- (I) Incoming and outgoing feeder name shall be displayed on Panel by screen printing.

6. STANDARD SPECIFICATION

The equipments shall conform to latest addition of IS Specification including:

- a) IS:13947/Pt.II/1993 & IEC 60947-2. - Air circuit breaker voltage not exceeding 1000V.
- b) IS: 1897/1983 -Copper bus bars.
- c) IS:8623/Pt.I to Pt.II/1993 - Marking & arrangement of switch gear bus bars, connections & auxiliary wiring.
- d) IS 13947/Pt.II/1993 & IEC – MCCB 60947-2.
- e) IS:13703/1993 - HRC fuses.
- f) IS:2705/Pt.I to IV/1992 as applicable - Current Transformer
- g) IS 13947 : Part 1 : 1993 - Specification for Low-voltage Switchgear and Controlgear - Part 1 : General Rules Measuring instruments shall have accuracy Class I.

7. SHEET STEEL TREATMENT AND POWDER COATING

- (a) Sheet Steel materials used in construction of these units should have undergone a rigorous rust proofing process comprising alkaline degreasing, descaling in dilute sulfuric acid and a recognized phosphating process. Steel work shall then receive two dip-coats of oxide filler/ primer before final painting. Castings shall be scrupulously cleaned and fettled before receiving a similar oxide primer coat. Manufacturer is required to have seven tank treatment facility for this.
- (b) All sheet steel shall after metal treatment be powder coated with two coats of shade 692 or as approve to IS:5 on outside and white on inside. Each coat of paint shall be properly stoved and paint thickness shall not be less than 80 microns. Panel manufacturer should have in-house power coating facility.

8. TECHNICAL PARTICULARS

Tenderer shall submit full description literature and technical particulars of equipment offered. All equipment/instruments should have test certificate of the recognized/NTH to confirm to relevant IS: Specification.

9. DRAWINGS

General arrangement and wiring drawings shall be got approved by successful tenderer before manufacturing switchboard from railways. Design calculation busbar layout shall be got approved in advance from Railways.

10. DANGER NOTICE PLATES

Danger Notice plates shall be fixed on front and back panels conforming to IS: 2551/63.

11. PACKING & TRANSPORTATION.

Complete LT Panel should be packed in such a way that there should not be any scratches on Panel during transportation.

12. TESTING & INSPECTION

- (i) Original test certificates of all equipments/instruments shall be submitted along with the supply of panel board after Inspecting Officer passes LT panel board.
- (ii) Certificate for all routine and type tests for circuit breakers in accordance with the IS:13118-1991 shall be furnished.
- (iii) All panels shall be meggered phase to phase and phase to neutral using a 1000/500V Megger with all outgoing feeders in closed position. Megger value should not be less than 2.5 MΩ between phases and 1.5MΩ between phases and neutral.

NOTE: -

Manufacturer should have following:

- a) ISO 9001 certification
- b) Testing facilities as per relevant IS and
- c) Powder coating arrangement.

Pre-Fabricated Double Door L.T. Distribution Board

- (i) Wall/pillar mounted/ recessed type. Cubical type Distribution Board shall be pre-fabricated conforming to IS 8623/1993/Part I to III or Latest Version with degree of protection IP 42 of approved make. The boards shall be suitable to work on 415 Volts, 3 Phase 4 wire AC supply system.
- (ii) Moulded Case Circuit Breaker 4 Pole 35 KA breaking capacity shall have adjustable thermal setting & fixed magnetic setting and conforming to IS 13947/Pt.II/1993 or Latest Version. The MCCBs shall have spreader link and barriers as standard feature of manufacturer and MCB shall be 10 KA Breaking Capacity 'C' Series and conforming to IS 8828/1996 or Latest Version.
- (iii) Installation of distribution board shall be conforming to IS 732/1989 or Latest Version, 4648/1968 or Latest Version.
- (iv) The "C" series MCB shall conform as per IS 8828/1996 with Breaking Capacity 10 KA.

MS feeder post:- The four Nos. Aluminum bus bars should be minimum 400A capacity each. The capacity of bus bar may be increased as per current carrying capacity of XLPE cable (Basis of bus bar cross section will be maximum of 1A./sq.mm). The feeder post to be grouted with cement concrete ratio 1:2:4 means 1 ratio cement by volume + 2 ratio sand by volume + 4 ratio aggregates by volume. Drawing of Feeder post may be approved before supply.

Earthing arrangement The item will be executed as per clause No.2 of attached specification Annexure EARTHING CABLE LAYING WIRING. (Weight of GI pipe should be minimum 5.10 Kg per meter).

6 SWG GI wire:- This item shall be in conformity to IS 5613/Pt I sec I&II/1985 or Latest Version. G.I wire shall conform to relevant IS.

Laying of LT XLPE cable:-

The item shall be executed as per attached specification **ANNEXURE- LAYING OF CABLE**

SUPPLY & LAYING OF HDPE PIPE THROUGH TRENCHLESS METHOD

1. The HDPE pipe shall conform to IS 4984/1995. The HDPE pipe shall be supplied by the contractor as per IS 4984/1995 or Latest Version and this specification given here is only for laying of HDPE pipes by "No Dig" also called as Trenchless /Horizontal directional drilling method using Trenchless Technology.
2. The work involves supply and laying of HDPE pipes of 140 mm inner dia and 160 mm outer dia through Trenchless digging with HDD machines to a depth of not less than 1000mm from ground level. The trench should be taken up under Railway track or as required at site for avoiding any damage to existing underground utilities for Laying of HDPE pipes. Horizontal Boring and Inserting HDPE Pipe under railway track crossing in all type of soil
i.e. Hard/Sandy/Rocky etc at prescribed depth, including all civil works. Supply of all tools, other required equipments and consumable labour etc.
3. Tenderer shall be surveyed to identify and prevent damage to Telephone/Signal Cables and other underground services. The contractor will be responsible for all damages to the underground utilities and the compensation claimed by the service provider should be paid by the contractor failing which the same will be adjusted against any amounts due to the contractor including running/ final bills of this work.
4. The location of HDD machine (entry and exit points of bore) marking shall be given by

the site Engineer. The contractor has to remove the interlocking blocks, foot path stones and/or the foot path dividers (iron railings) in order to keep the HDD machine at the entry and exit points pits have to be taken to a depth of at least 2.0 mt or as required. As per the marking of the site engineer, the boring shall be done. After the bore reaches the exit point on the remote pit, If the site engineer is satisfied with the depth, the pipes are inserted and the bore is pulled back. The pipes are supplied in the length and they should be laid parallel on the ground. The pipes should be properly formed so that there is no coiling tendency for the pipes.

5. One number of pipe to be laid in one bore and the location will be advised by the site Engineer. At one location two pipes will be laid within two metre or as advised by the site Engineer as required. The pipes shall be brought above surface in the entry pit and end plugs are fixed tightly in the exit pit, the excess pipe is cut and the end plugs are tightly fixed. In case duct laying is completed on the other side, these pipes shall be connected to the existing ducts through couplers. After the boring work is completed, the pit shall be closed properly.

6. The Contractor shall be responsible for all necessary arrangements to remove or pump out water from trench. The Contractor should survey the soil conditions encountered in the section and make his own assessment about dewatering arrangements that may be necessary. No extra payment shall be admissible for this.

7. Wherever the soil is hard due to dry weather conditions, if watering is to be done for wetting the soil to make it loose, the same shall be done by the contractor. No extra payment shall be admissible for this.

8. Preparatory to aligning the pipe for jointing, each length of the pipe shall be thoroughly cleaned to remove all sand, dust or any other debris that may clog, disturb or damage the HT cable when it is pulled at a later stage. The ends of each pipe and inside of each HDPE Socket shall be thoroughly cleaned of any dirt or other foreign materials.

9. Safety precautions when excavating or working in excavations close to electric cables. The Engineering-charge of the work should get full information from Electricity undertaking regarding any electric cables, which are known or suspected to exist near the proposed excavation and unless this is done, excavation should not be carried out in the section concerned. The electricity undertaking should be asked to send a representative and work should be preceded with close consultation with them.

10. Care should be taken to see that apparatuses, tools or other excavating implements or excavated materials are not left in a dangerous or insecure position

11. The price covers laying of cable in HDPE pipe of this item.

CLS panel 150 Amp:-

Price covers Supply, fixing and commissioning of Automatic supply change over colour light signalling

panels, 150 Amp for 3 source single phase supply suitable for 25 KVA AT as per RDSO Specification No. TI/SPC/PSI/CLS/0020(12/02) with A&C slip No. 1 to 4 or latest .

AT panel for 10KVA Auxiliary Transformer:- Item shall be in conformity with RDSO specification no. ETI/PSI/035-02 or latest.

NOTE for all LED based luminaries: Firm shall give Certificate provided by Original Equipment Manufacturer duly mentioning the Date upto which warranty is valid, as per CEE/NR specification No. CEE/NR/121- Elect/PS/2018 (Rev.03) dated 28.06.2018 & CEE/NR/121- Elect/PS/2019 (Rev.4) dated 04.11.2019 Supplier shall arrange Undertaking from OEM, certifying that Warranty shall be enforceable by Railways as per Warranty certificate provided and OEM shall provide complete warranty even after maintenance period of the Supplier is over and Security money is released.

Scope of the work

1. The Goomty are required for the EI works in connection with signalling work in FZR Division.
2. The Goomty are to be constructed as per the given specification.
3. The progress of the Goomty work are commensurate with signalling works.
4. The work of the Goomty are spread in PHR-LNK, DHW-SRM and VKA-CHN sections as defined in the work.
5. The completion of the Goomty works is the 6 Months and Contractor has to start the work in parallel in 03 Sections so as to complete the construction of Goomty in all respect within 6 months after the issue of LOA.



VOLUME – IV

SCHEDULE OF WORK

Available on www.ireps.gov.in



VOLUME – V

DRAWING OF GATE GOOMTY

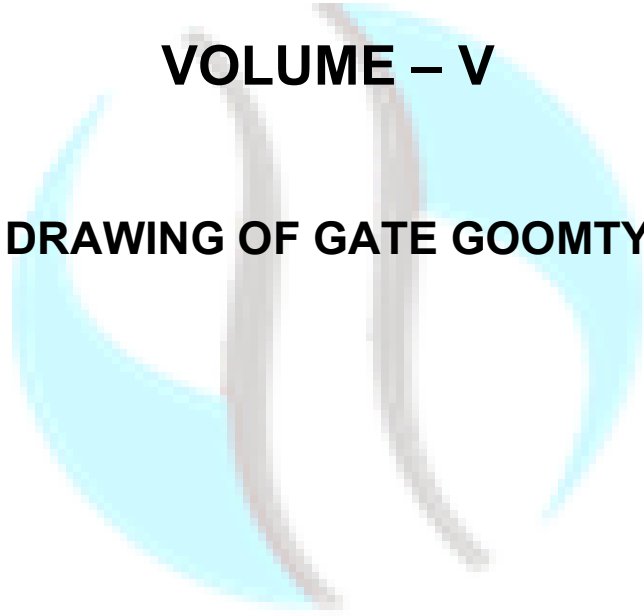

रेलटेल
RAILTEL

- NOTE:-**
1. ALL DIMENSIONS ARE IN MM & LEVELS ARE IN METER
 2. ANY DISCREPANCY IN THE DRWG SHOULD BE BRUGHT TO THE ATTENTION OF CONSULTANT BEFORE EXECUTION
 3. DRAWING IS NOT TO BE SCALED ONLY WRITTEN DIMENSION SHOULD BE FOLLOWED
 4. LOAD HAS BEEN TAKEN FOR (G+1) FLOOR ONLY
 5. THE MIX FOR ALL R.C.C WORK SHALL BE (1:1.5:4)
 6. THE MIX FOR ALL R.C.C WORK SHALL BE M-20
 7. ALL BRICK WORK TO BE DONE IN CEMENT MORTAR 1:5 EXCEPT THE WALL WHICH WILL BE CONSTRUCTED IN CEMENT MORTAR 1:4
 8. BUILDING IS DESIGNED FOR EARTHQUAKE LOAD OF ZONE III

SCALE	AS SHOWN
UNIT	MILLIMETER
DATE	16/08/2023
PROJECT	REPAIR AND REPLACEMENT OF MECHANICAL SIGNALLING LAMP FRAME WITH ELECTRICAL MARKING
TITLE	FOUNDATION PLAN
REF DWG NO	REF-DWG NO DHB/STR/02
DWG NO	REL/NO DHB/01-000
Sheet No.-	03/05

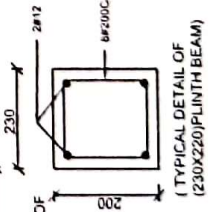
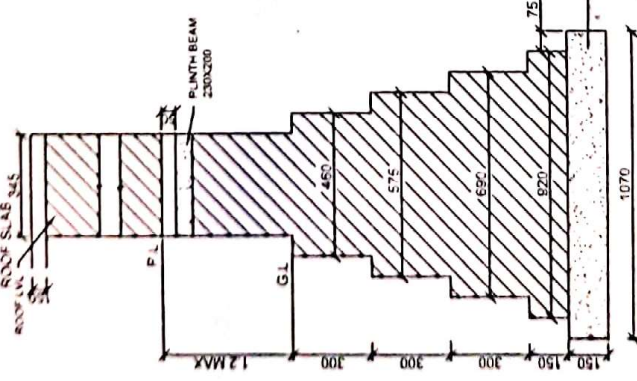
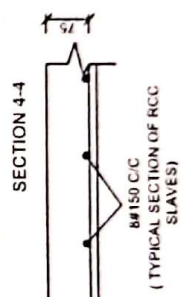
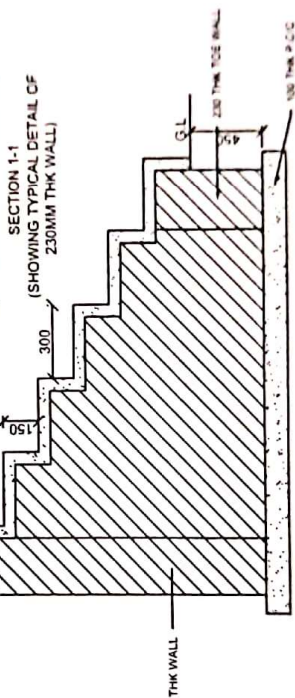
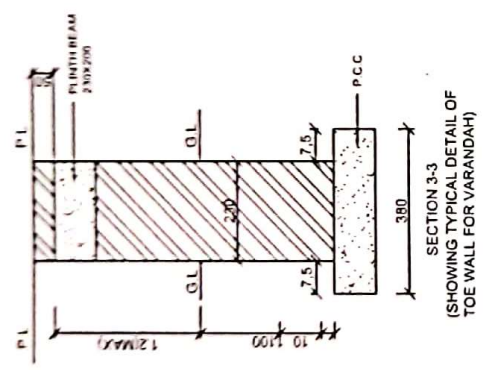
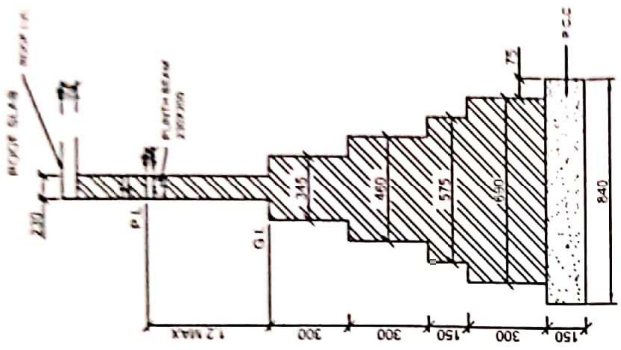

DESIGNER	APPROVED	CHECKED	DATE
CESIGNAL	APPROVED	APPROVED	DATE

(FOR LOCATION OF FOUNDATION LAYOUT REFER DRAWING NO DHB/STR/01)

85A 9A

- NOTE -
1. ALL DIMENSIONS ARE IN MM & LEVELS ARE IN METER.
 2. ANY DISCREPANCY IN THE DRG SHOULD BE BROUGHT TO THE KNOWLEDGE OF CONSULTANT BEFORE EXECUTION.
 3. GRADING IS NOT TO BE SCALED ONLY WRITTEN DIMENSIONS SHOULD BE FOLLOWED.
 4. LOADS HAS BEEN TAKEN FOR (G+1) FLOORS ONLY.
 5. THE MIX FOR ALL P.C.C. WORK SHALL BE (1:1.8).
 6. THE MIX FOR ALL P.C.C. WORK SHALL BE M25.
 7. ALL ROOF WORK TO BE DONE IN CEMENT MORTAR 1:6 EXCEPT 1:15 THIN WALL WHICH WILL BE CONSTRUCTED IN CEMENT MORTAR 1:4.
 8. BUILDING IS DESIGNED FOR EARTHQUAKE LOAD OF ZONE III.

PROJECT NO.	RCIL-SIG-GOOMTY_23-24-15
DATE	16.08.2023
SCALE	AS SHOWN
DESIGNED BY	...
CHECKED BY	...
DATE OF ISSUE	...
FOR APPROVAL	...
FOR CONTRACT	...
FOR EXECUTION	...
FOR RECORD	...
TITLE	TYPICAL FOUNDATION PLAN
BUILDING NO./P.W. NO./M.C. NO./SUBSTATION	...
DWG. NO.	RCIL/SIG/GOOMTY/23-24-15/001
Sheet No.	04/05

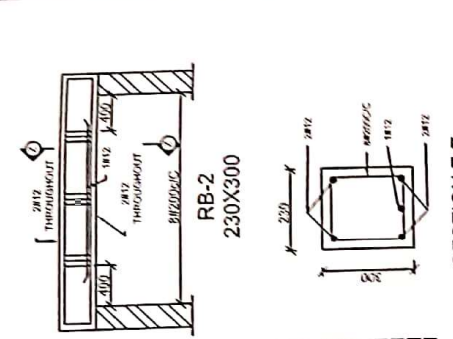

SECTION Z-Z

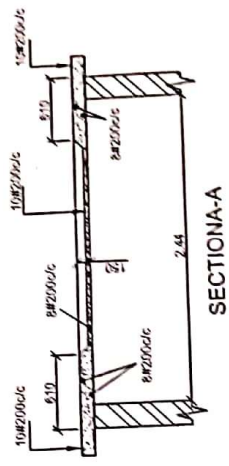

SECTION A-A

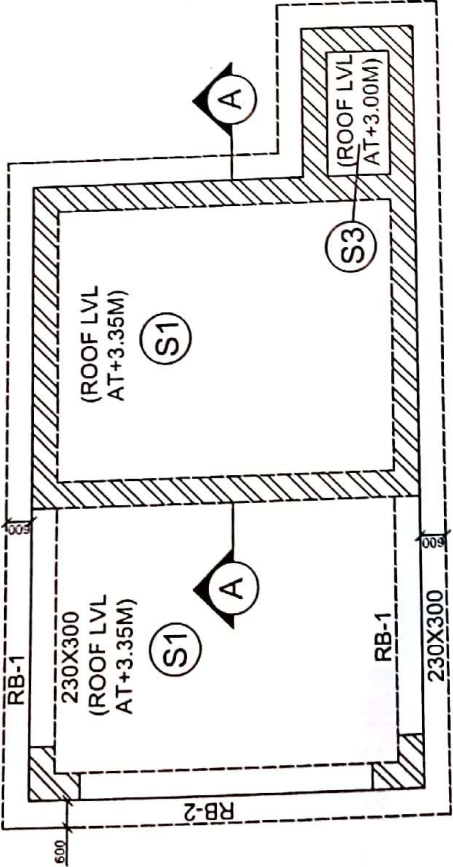

ROOF LAYOUT

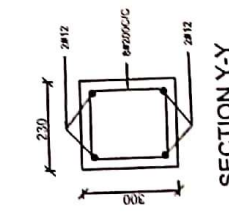

SECTION Y-Y

SLAB SCHEDULE			
SLAB MKD.	THICKNESS MM	REINFORCEMENT (Bottom)	
		SHORT SPAN	LONG SPAN
S-1	150	10mm@200c/c	8mm@200c/c
		10mm@200c/c	8mm@200c/c

DESIGNED BY: [Signature]
 CHECKED BY: [Signature]
 APPROVED BY: [Signature]

NOTE:- PLINTH LEVEL IS CONSIDERED ±0.00M

- NOTE -**
1. ALL DIMENSION ARE IN MM & LEVELS ARE IN METER
 2. ANY DISCREPANCY IN THE DRG SHOULD BE BROUGHT TO THE KINDR ATTENTION OF CONSULTANT BEFORE EXECUTION
 3. DRAWING IS NOT TO BE SCALED ONLY WRITTEN DIMENSION SHOULD BE FOLLOWED
 4. LOAD HAS BEEN TAKEN FOR (G+1) FLOORS ONLY
 5. THE MIX FOR ALL P.C.C WORK SHALL BE (1:4:8)
 6. THE MIX FOR ALL R.C.C WORK SHALL BE M-25
 7. ALL BRICK WORK TO BE DONE IN CEMENT MORTAR 1:6 EXCEPT 115 THK WALL WHICH WILL BE CONSTRUCTED IN CEMENT MORTAR 1:4
 8. BUILDING IS DESIGNED FOR EARTHQUAKE LOAD OF ZONE III

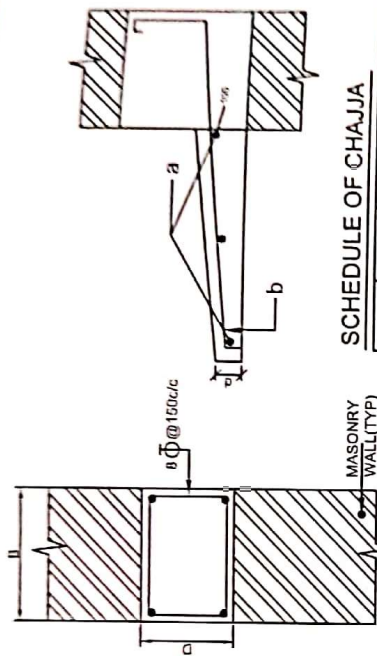

SECTION X-X
TYP. LINTEL DETAIL

SCHEDULE OF CHAJJA	
L (mm)	d (mm)
600	65

REINFORCEMENT	
a	b
8# @ 100c/c	3-# @ 800c/c

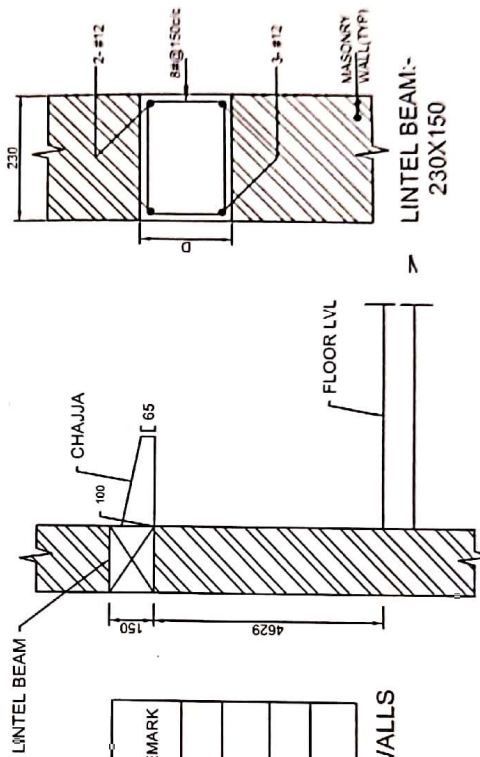

TYPICAL SECTION OF LINTEL WITH CHAJJA

SPAN (mm)	B (mm)	D (mm)	BOT REINF	TOP REINF	STEPS	REMARK
UP TO 750	115	150	2-12#	2-10#	8# @ 150c/c	
	230	150	3-12#	2-10#	8# @ 150c/c	
1000	115	150	2-12#	2-10#	8# @ 150c/c	
	230	150	3-12#	2-10#	8# @ 150c/c	

LINTEL BAND SHALL BE LAID THROUGH THE WALLS

LEGEND	EXISTING BRICK WORK	PLASTER 1:4	DO CENTER TO CENTER
	CONCRETE	THE THICKNESS	AS SHOWN
	MASONRY	AS SHOWN	
NAME OF PROJECT Upgradation and Replacement of Mechanical Spalling Level Frame With Electrical Interlocking			
TITLE - DUTY BUNK BUILDING			
TYPICAL FOUNDATION PLAN			
Ref DWG NO.- R/VNL DWG NO DH8/STR02			
DWG NO.- REL/CV/DH-01-2020			
Sheet No.- 05/05			

DRAWN BY	DESIGNED BY	CHECKED BY	APPROVED BY
CE/SIGNAL	MR/CONCRETE	MR/STRUCTURE	DR/SIG/REL

- NOTE:-
1. ALL DIMENSION ARE IN MM & LEVELS ARE IN METER.
 2. ANY DISCREPANCY IN THE DRG. SHOULD BE BROUGHT TO THE KNOWLEDGE OF CONSULTANT BEFORE EXECUTION
 3. DRAWING IS NOT TO BE SCALED ONLY WRITTEN DIMENSION SHOULD BE FOLLOWED.
 4. LOAD HAS BEEN TAKEN FOR (G+1) FLOORS ONLY.
 5. THE MIX FOR ALL P.C.C WORK SHALL BE (1:4:8)
 6. THE MIX FOR ALL R.C.C WORK SHALL BE M-25
 7. ALL BRICK WORK TO BE DONE IN CEMENT MORTAR 1:6 EXCEPT 115 THK. WALL WHICH WILL BE CONSTRUCTED IN CEMENT MORTAR 1:4.
 8. BUILDING IS DESIGNED FOR EARTHQUAKE LOAD OF ZONE III.

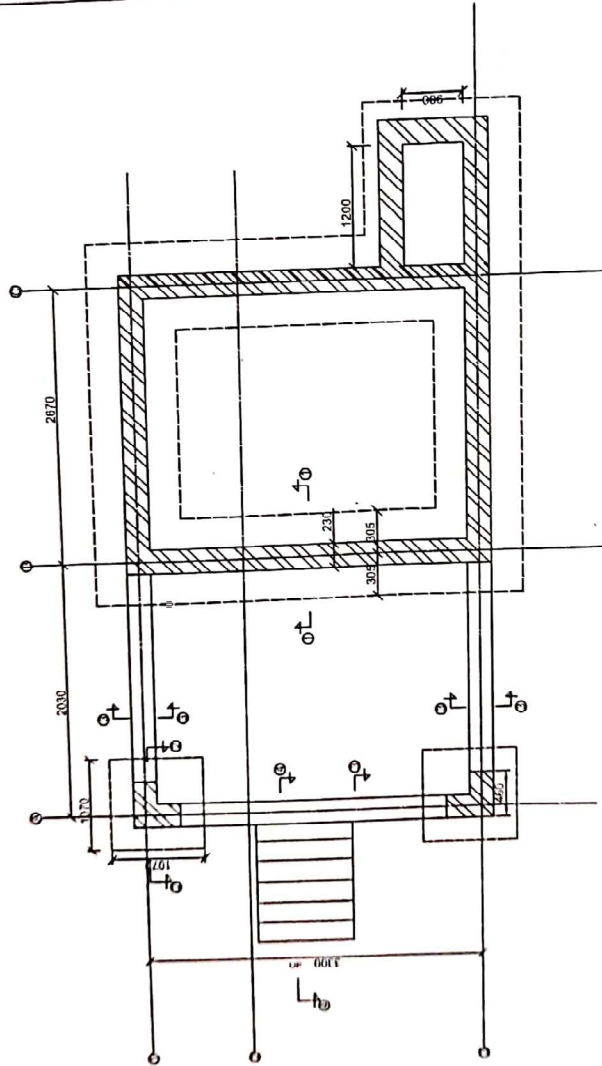

FOUNDATION LAYOUT

NOTE:-
PLINTH LEVEL IS CONSIDERED ±0.00M

(FOR LOCATION DETAIL OF SECTION 1-1, SECTION 2-2, SECTION 3-3, SECTION 4-4, REFER DRAWING NO-DHB/STR/02

LEGEND	200 THK BRICK WORK	PLAIN P.C.C
	CONCRETE	FOR WORKS
	SAND FILLING	OC-CENTER TO CENTER
NAME OF PROJECT	Upgradation and Replacement of Mechanical Signalling Level Frame With Electronics Interlocking	
TITLE	DUTY BUNK BUILDING	
REF DWG NO.-RVNL DWG NO DHB/STR/02	DWG NO.- RELIC/UDHB.01-2020	
Sheet No.:	01/05	

				DOMESTIC REL
				MANUFACTURE
				CENTRAL



रेलटेल
RAILTEL

- NOTE:-
1. ALL DIMENSION ARE IN MM & LEVELS ARE IN METER.
 2. ANY DISCREPANCY IN THE DRG. SHOULD BE BROUGHT TO THE KNOWLEDGE OF CONSULTANT BEFORE EXECUTION.
 3. DRAWING IS NOT TO BE SCALED ONLY WRITTEN DIMENSION SHOULD BE FOLLOWED.
 4. LOAD HAS BEEN TAKEN FOR (G+1) FLOORS ONLY.
 5. THE MIX FOR ALL P.C.C WORK SHALL BE (1:4:8)
 6. THE MIX FOR ALL R.C.C WORK SHALL BE M-25
 7. ALL BRICK WORK TO BE DONE IN CEMENT MORTAR 1:6 EXCEPT 1:5 THK. WALL WHICH WILL BE CONSTRUCTED IN CEMENT MOTOR 1:4.
 8. BUILDING IS DESIGNED FOR EARTHQUAKE LOAD OF ZONE III.

LEGENDS	230 115THK BRICK WORK	PLASTER LVL
	CONCRETE	THK-THESSNESS
	SAND FILLING	TYP-TYPICAL
		CC-CENTER TO CENTER
NAME OF PROJECT - Upgradation and Replacement of Mechanical Signalling Lever Frame With Electronics Interlocking		
TITLE:- DUTY BUNK BUILDING		
TYPICAL FOUNDATION PLAN		
Ref DWG NO- RVNL DWG NO.DHB/STR02		
DWG NO- REL/CIVIL/DHB/01-2020		
Sheet No.-		02/05

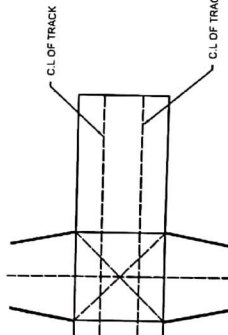
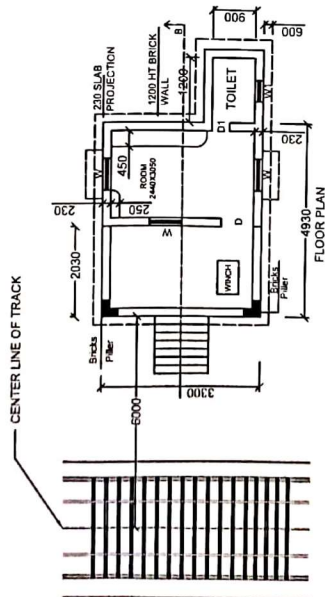
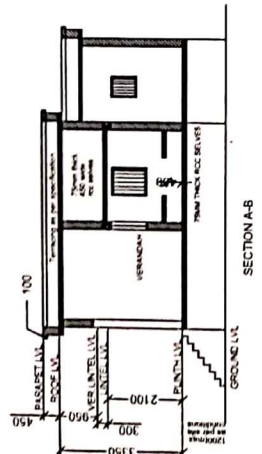
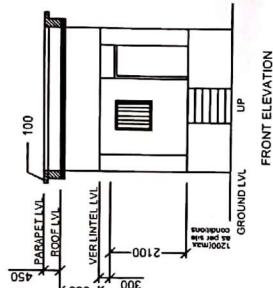
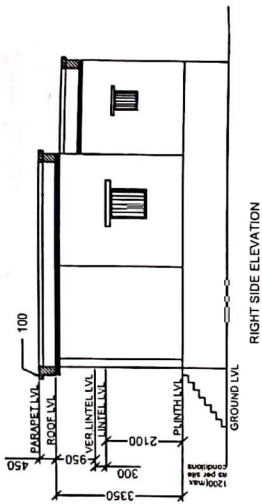

SL NO	NAME	SIZE
1	D	900X2100
2	D1	800X2100
3	W	900X1200
4	W1	600X600

DRAWN BY: *[Signature]*

CE/SIGNAL: *[Signature]*

MR/CIVIL/REL/AG/01/01/REL: *[Signature]*

DM/SIG/REL: *[Signature]*

END OF TENDER DOCUMENT



रेलटेल
RAILTEL